

Office 365 - The Network Story



Frank Carius

aMS Berlin 2022
19. Mai



Thanks to our SPONSORS

Vielen Dank an unsere Partner!

Organizing sponsor



M365 Kaffeepause
Learning in the flow of work.

*DIAMOND
sponsors*



*PLATINUM
sponsor*

*Organisatorischer
Partner*

Kurzvorstellung

Net at Work GmbH

Standort Paderborn

Gegründet 1995

125+ Mitarbeiter

IT-Systemintegration und Software Development

Schwerpunkte

UC: Exchange, Skype for Business, Teams

SharePoint, Office 365, Microsoft 365

Infrastruktur: AD, ADFS, ADSync, Netzwerk

Security: Mail Encryption und Signierung, NoSpamProxy

Frank Carius

Microsoft MVP für Office Server Systems

Microsoft Certified Master Lync 2010

Betreiber von www.msxfaq.de

 **Net at Work**
Building IT-Excellence.



Microsoft Partner
Gold Messaging
Gold Communications
Gold Collaboration and Content
Gold Cloud Productivity
Gold Application Development

noSpam
proxy®



Microsoft
CERTIFIED
Master



Stellen Sie sich vor...

Sie stehen an der Werksausfahrt und ...

- ... zählen die LKWs
- ... wiegen die LKWs
- ... hilft ihnen das weiter?

Das ist SNMP-Monitoring !

SNMP bedeutet ...

- ... wir messen Anzahl der Pakete In/Out
- ... wir messen Kilobyte In/Out

Sollten wir nicht besser messen, ...

- ... wie lange der LKW zum Kunden unterwegs ist
- ... wie viele davon pünktlich sind oder zu spät kommen
- ... wie viele „verloren“ gehen ?

Wie messe ich „Pünktlichkeit“ ?



Herausforderung – Die Entwicklung der Cloud Anbindung

- **Vor der Nutzung on Cloud-Diensten**
 - › Strukturierte Vorgehensweise mit Daten sammeln und Abschätzungen
 - › Wie viel Bandbreite ist vorhanden
 - › Wie finden wir heraus, wie viel Bandbreite die Dienste benötigen
 - › Wie viel Bandbreite müssen wir hinzukaufen (\$\$\$)
 - › Wer kann uns das „zusichern“ (Netzwerk-TÜV“)
- **Frühjahr 2020: Homeoffice, VPN Inbound, COVID**
 - › Leitungen waren zu knapp für VPN und Skype for Business OnPremises
 - › VPN-Server und Sessions/Lizenzen waren zu knapp bemessen
 - › Beschleunigte Migration zu Cloud-Diensten. Insbesondere Teams, Zoom, ...)
 - › Zusätzliche VPN-Server und Bandbreite in kurzer Zeit
- **Sommer 2021: Back to Office – Viel mehr ausgehender Verkehr**
 - › Mitarbeiter sind wieder vermehrt in der Firma
 - › Aber Sie behalten die Arbeitsweisen bei.
 - › Teams Meetings mit MCU in der Cloud, OneDrive, u.a.
- **Heute**
 - › Troubleshooting der schönen heilen Welt



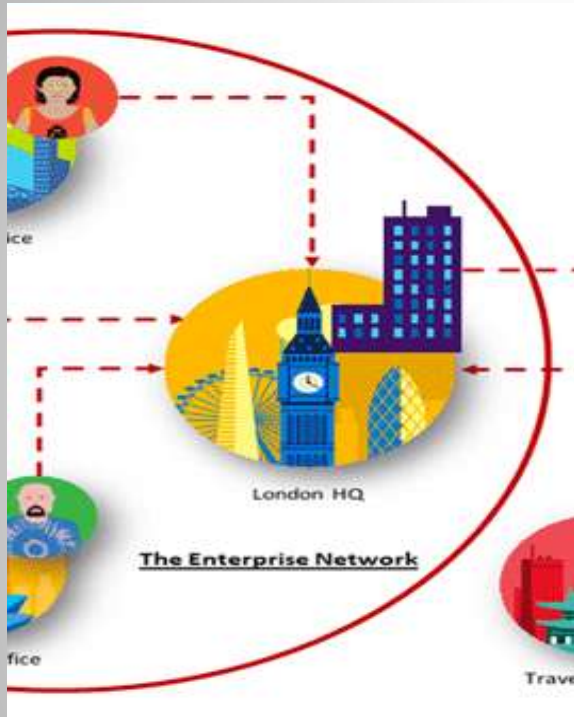

What Microsoft tells us

Die einzigen “geklauten” Folien
<https://aka.ms/netvideos>



Office 365 Guiding Principles

Identify and differentiate Office 365 traffic using Microsoft published endpoints



aka.ms/o365ip

Egress Office 365 data connections as close to the user as practical with matching DNS resolution

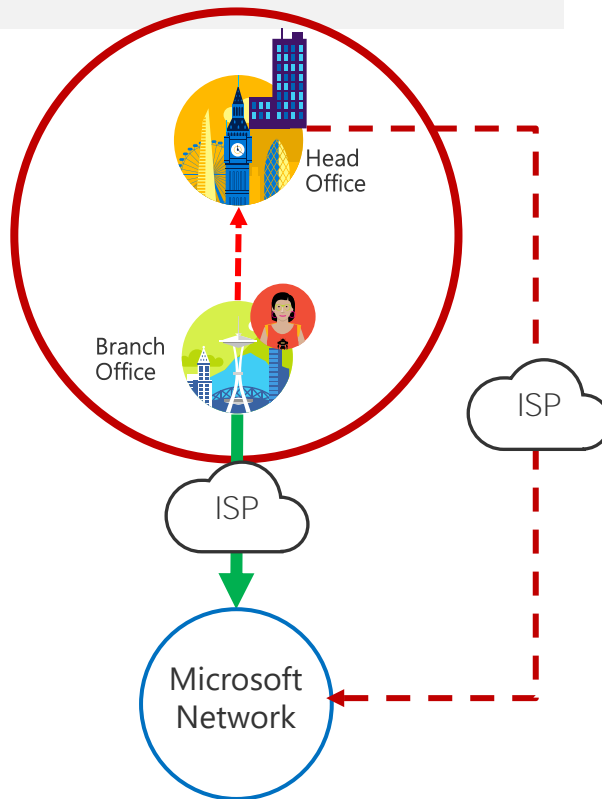

Avoid network hairpins and optimize connectivity directly into the nearest entry point into Microsoft's global network

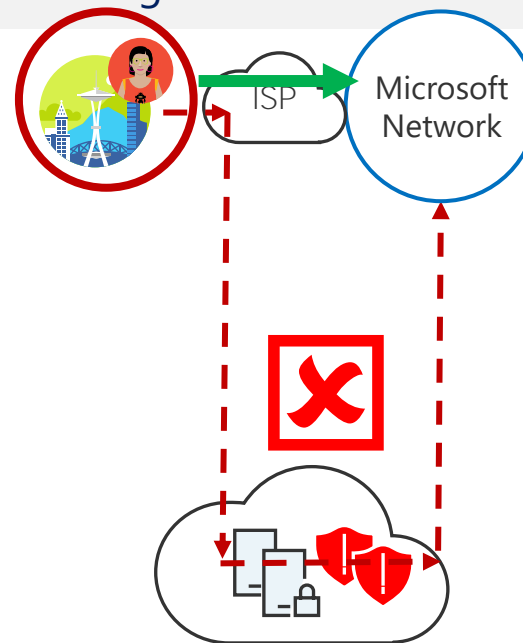

Assess bypassing proxies, traffic inspection devices and duplicate security which is available in Office 365

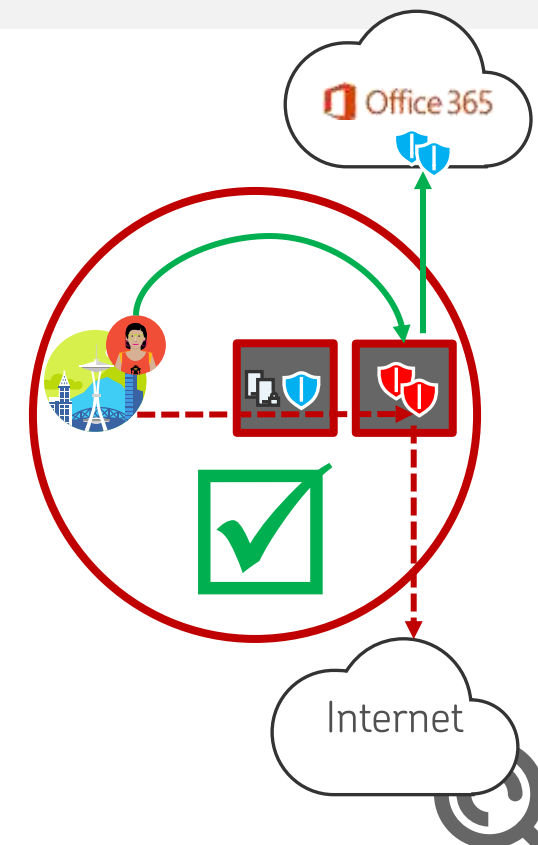

Target: Optimize, Allow and Default

Office 365 endpoints (FQDNs, IPs, ports, protocols)

- Office 365 REST API (<http://aka.ms/ipurlws>) for automating customer Office 365 network settings
- Priority driven endpoint taxonomy (<http://aka.ms/ipurlblog>) for easier customer network optimizations
- Growing support for native integration across partner community
- **Key point: Focus your network optimization on key Office 365 experiences first (Optimize set)**

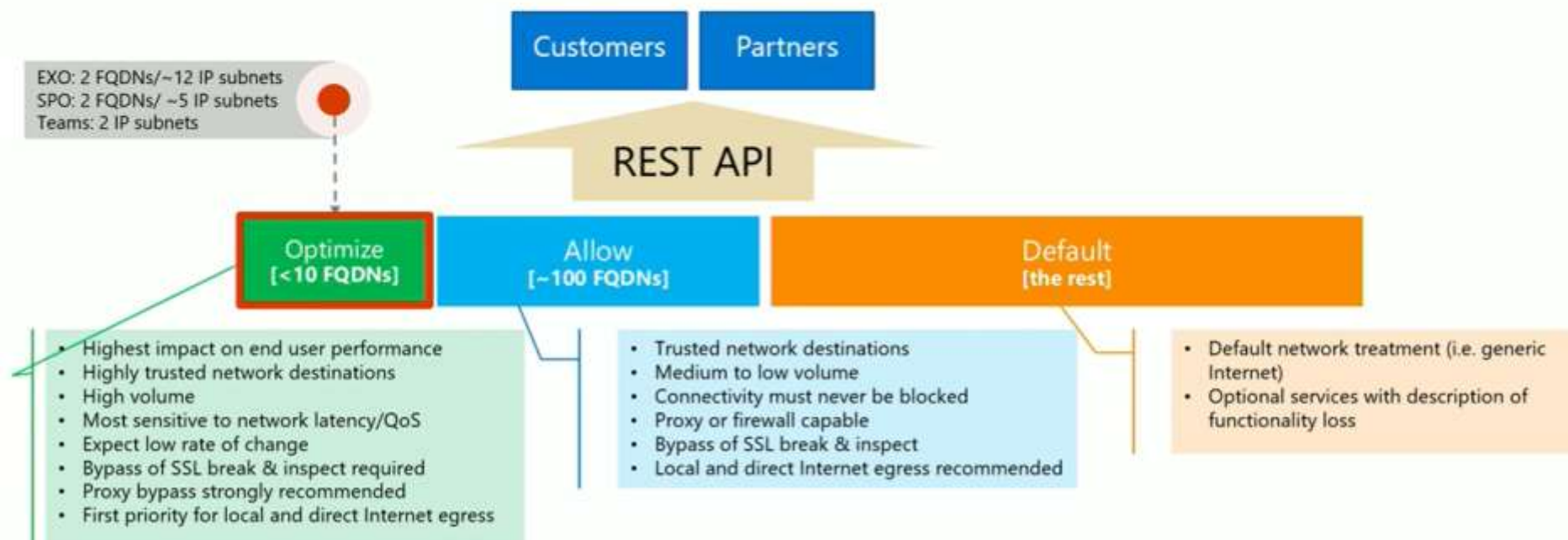

Optimal network connectivity for Office 365 performance: What is it and how to get | BRK3040

Source: <https://youtu.be/XiQwR12rk08?t=1564>

Microsoft Global Network

- Weltweit
- Verteilt



Microsoft Global Network

- Microsoft betreibt ein sehr großes WAN
 - > über 190 Peering Location, 2700 ISP Partner, 100 Frontdoor-Locations, 45 Datacenter
 - > Eigene Glasfaser (angeblich 800.000km in den USA)
[http://download.microsoft.com/download/8/2/9/8297F7C7-AE81-4E99-B1DB-D65A01F7A8EF/Microsoft Cloud Infrastructure Datacenter and Network Fact Sheet.pdf](http://download.microsoft.com/download/8/2/9/8297F7C7-AE81-4E99-B1DB-D65A01F7A8EF/Microsoft%20Cloud%20Infrastructure%20Datacenter%20and%20Network%20Fact%20Sheet.pdf)
 - > Mehrere Terabit Peering
 - > QoS – verwaltet
 - > BRK3000 - Strategies for building effective, optimal and future proof connectivity to Office 365 that will delight your users
- BGP: Microsoft ASN= 8075
 - > <https://aka.ms/8075> / <https://www.peeringdb.com/asn/8075>
 - > <https://stat.ripe.net/AS8075#tabId=at-a-glance>
<https://stat.ripe.net/ui2013/8075#tabId=at-a-glance>
 - > IPv4 Prefixes:243 insgesamt 44.816.640 IPs
 - > IPv6 Prefixes:19 insgesamt 8.523.790 /48s
 - > http://www.msxfaq.de/cloud/verbindung/o365_netzwerkziele.htm
- Peering List für Azure
 - > <https://docs.microsoft.com/en-us/rest/api/peering/peeringlocations/list>

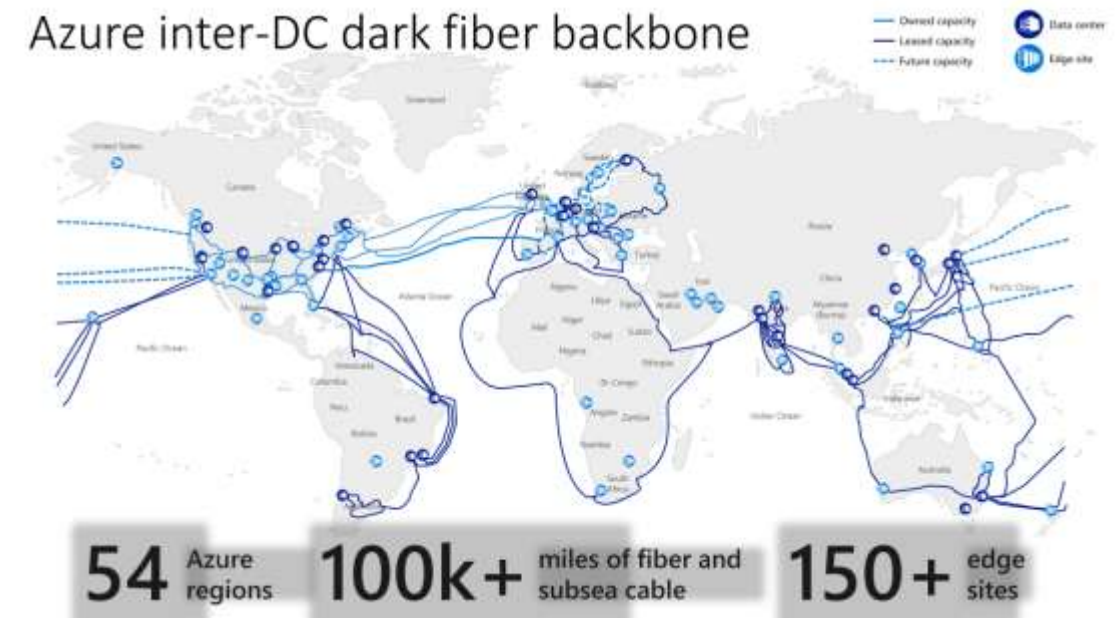

Der Weg vom Client zum Service

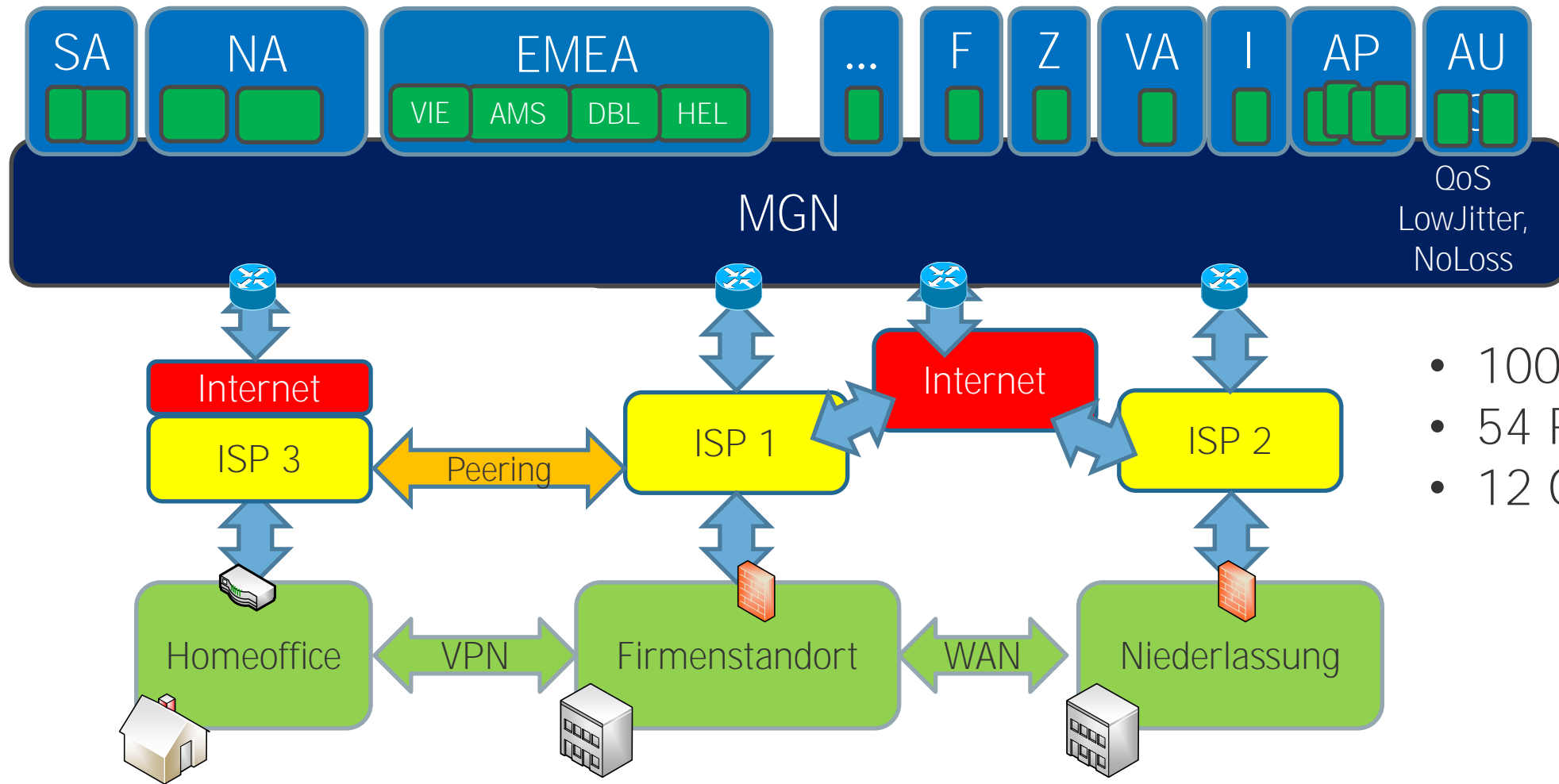

- 100+ Azure RZs
- 54 Regionen
- 12 Geos

<https://products.office.com/de-de/where-is-your-data-located>

<https://docs.microsoft.com/en-us/Office365/Enterprise/moving-data-to-new-datacenter-geos>

<https://o365datacentermap.azurewebsites.net/>

Office 365 ist nicht Internet

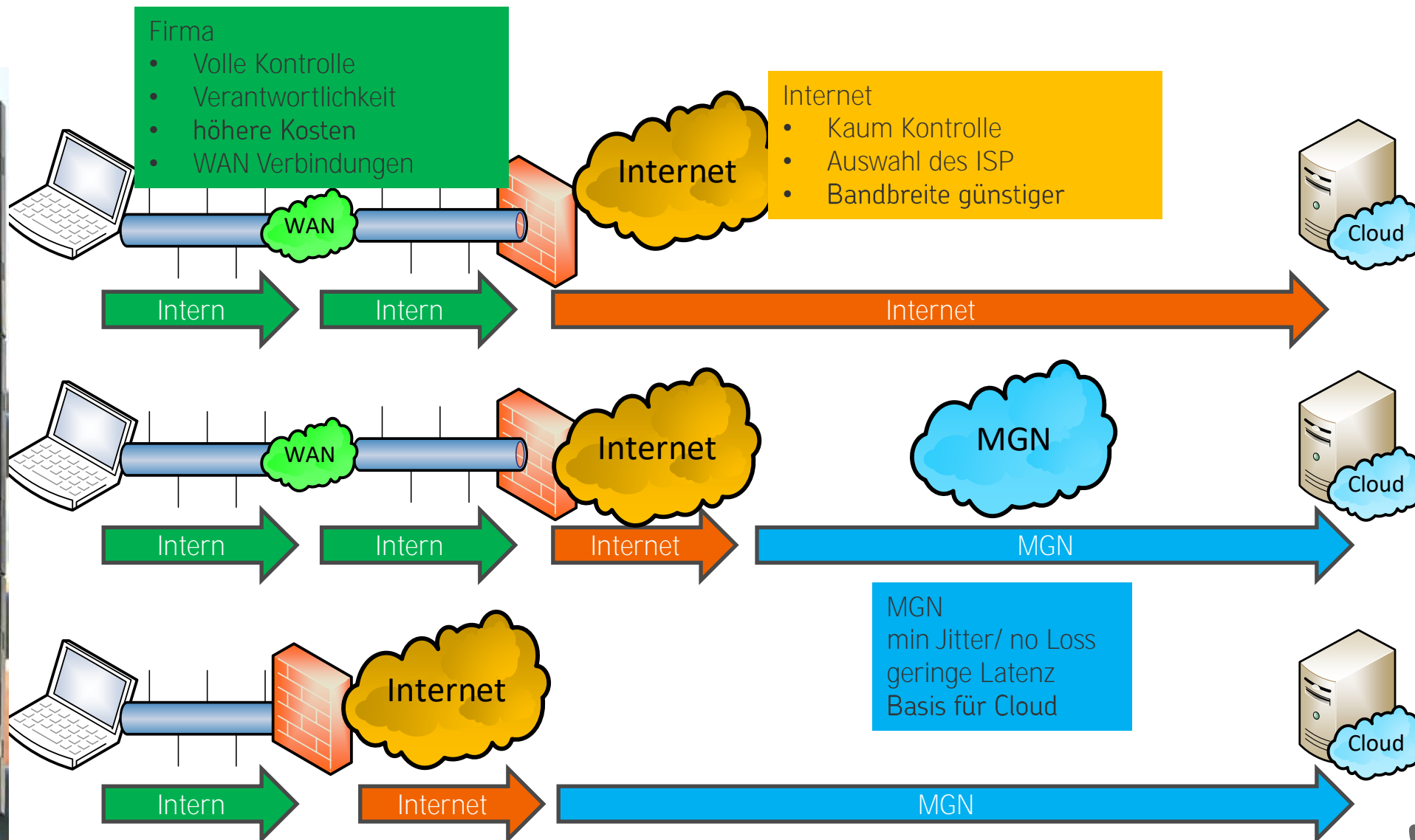

Peerings mit Providern

- **Expressroute**
 - › Eigene Leitung zu Azure
 - › BGP-Routing
 - › POP in Amsterdam und Rotterdam
- **Provider mit Peerings (Auszug)**
 - › Peering Service Preview Partners
<https://docs.microsoft.com/en-us/azure/peering-service/location-partners>
 - › DeCIX Azure Peering Services
<https://www.de-cix.net/en/de-cix-service-world/closed-user-groups/microsoft-azure-peering-service>
 - › Colt
<https://www.colt.net/why-colt/strategic-alliances/microsoft-partnership/>
 - › InterCloud
<https://intercloud.com/partners/microsoft-saas-applications/>
 - › interxion
<https://www.interxion.com/why-interxion/colocate-with-the-clouds/Microsoft-Azure/>
- **Office 365 Network Onboarding tool**
 - › <https://o365networkonboarding.azurewebsites.net/> (Down)

Microsoft Peering

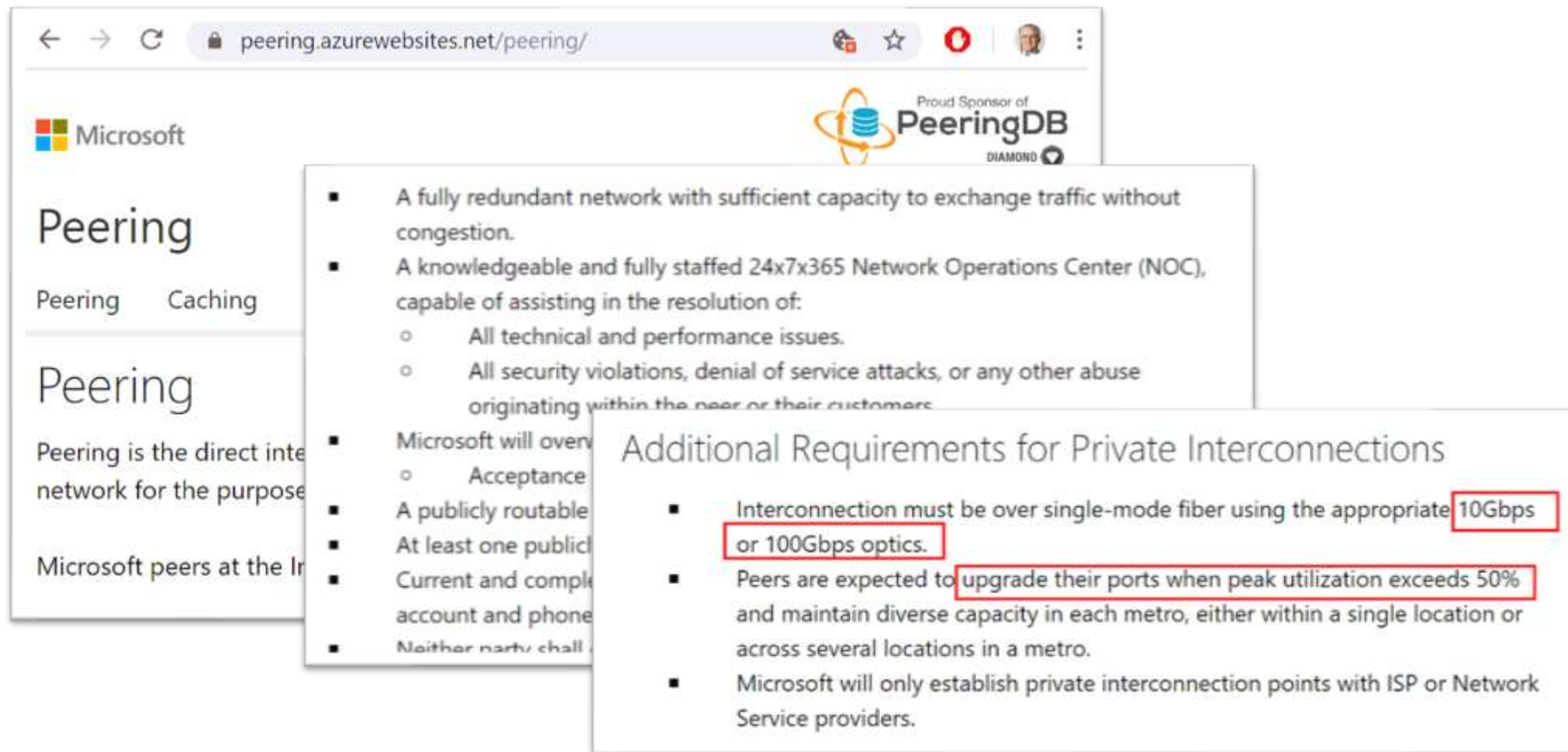

The screenshot shows the Microsoft Peering website at peering.azurewebsites.net/peering/. The page features the Microsoft logo, a navigation menu with 'Peering' and 'Caching', and a 'Peering' section. A 'Proud Sponsor of PeeringDB' badge is visible in the top right. Three callout boxes are overlaid on the page:

- Callout 1:** A fully redundant network with sufficient capacity to exchange traffic without congestion.
 - A knowledgeable and fully staffed 24x7x365 Network Operations Center (NOC), capable of assisting in the resolution of:
 - All technical and performance issues.
 - All security violations, denial of service attacks, or any other abuse originating within the peer or their customers.
- Callout 2:** Microsoft will overv
 - Acceptance
- Callout 3: Additional Requirements for Private Interconnections**
 - Interconnection must be over single-mode fiber using the appropriate **10Gbps or 100Gbps optics.**
 - Peers are expected to **upgrade their ports when peak utilization exceeds 50%** and maintain diverse capacity in each metro, either within a single location or across several locations in a metro.
 - Microsoft will only establish private interconnection points with ISP or Network Service providers.



Grundlagen der Verbindung

- Lokaler Breakout
- DNS Auflösung
- Proxy Bypass / NAT
- Deep Inspection/Trusted Zone



Lokaler Breakout vs. zentraler Breakout

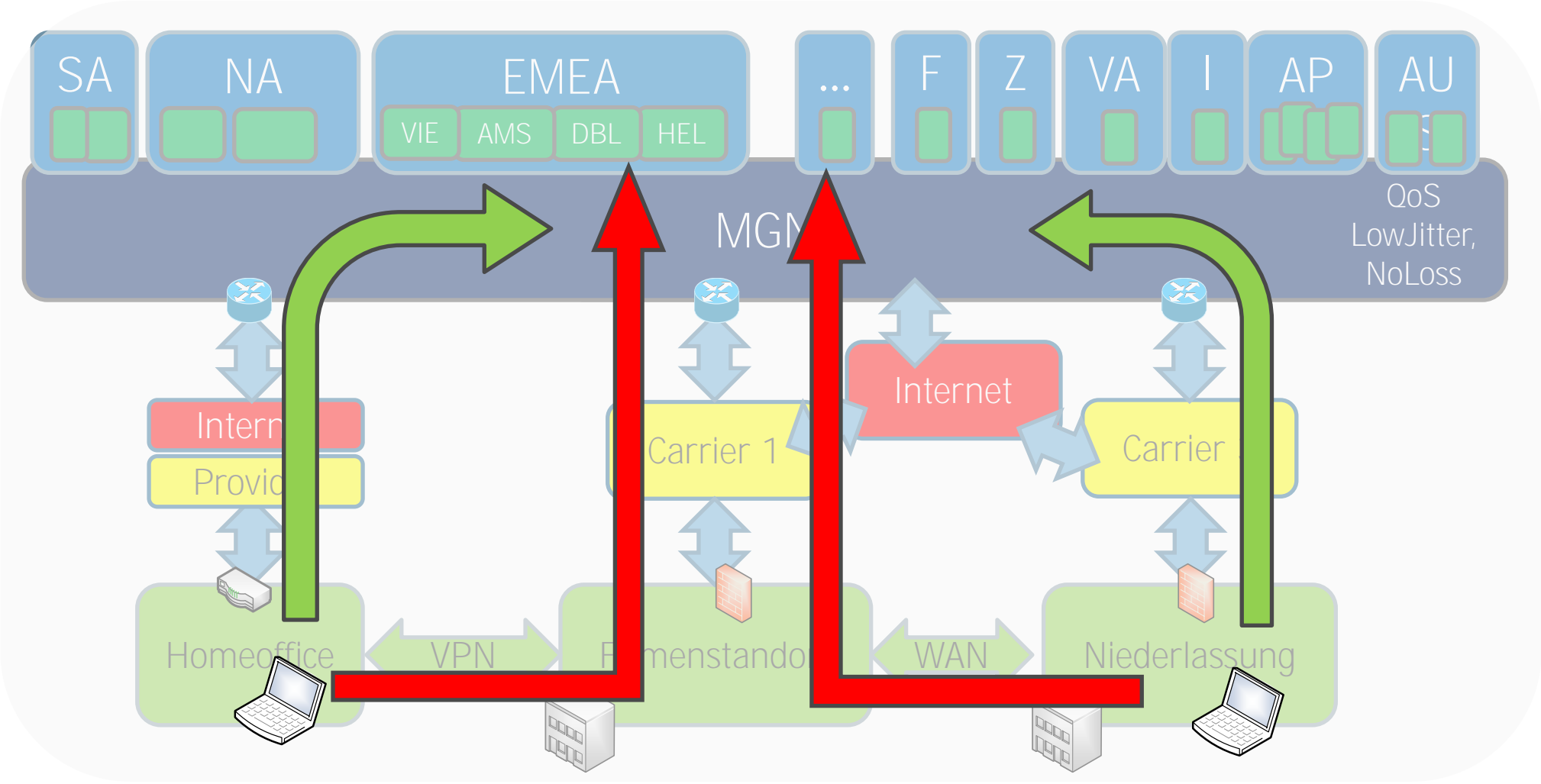

DNS-Resolution

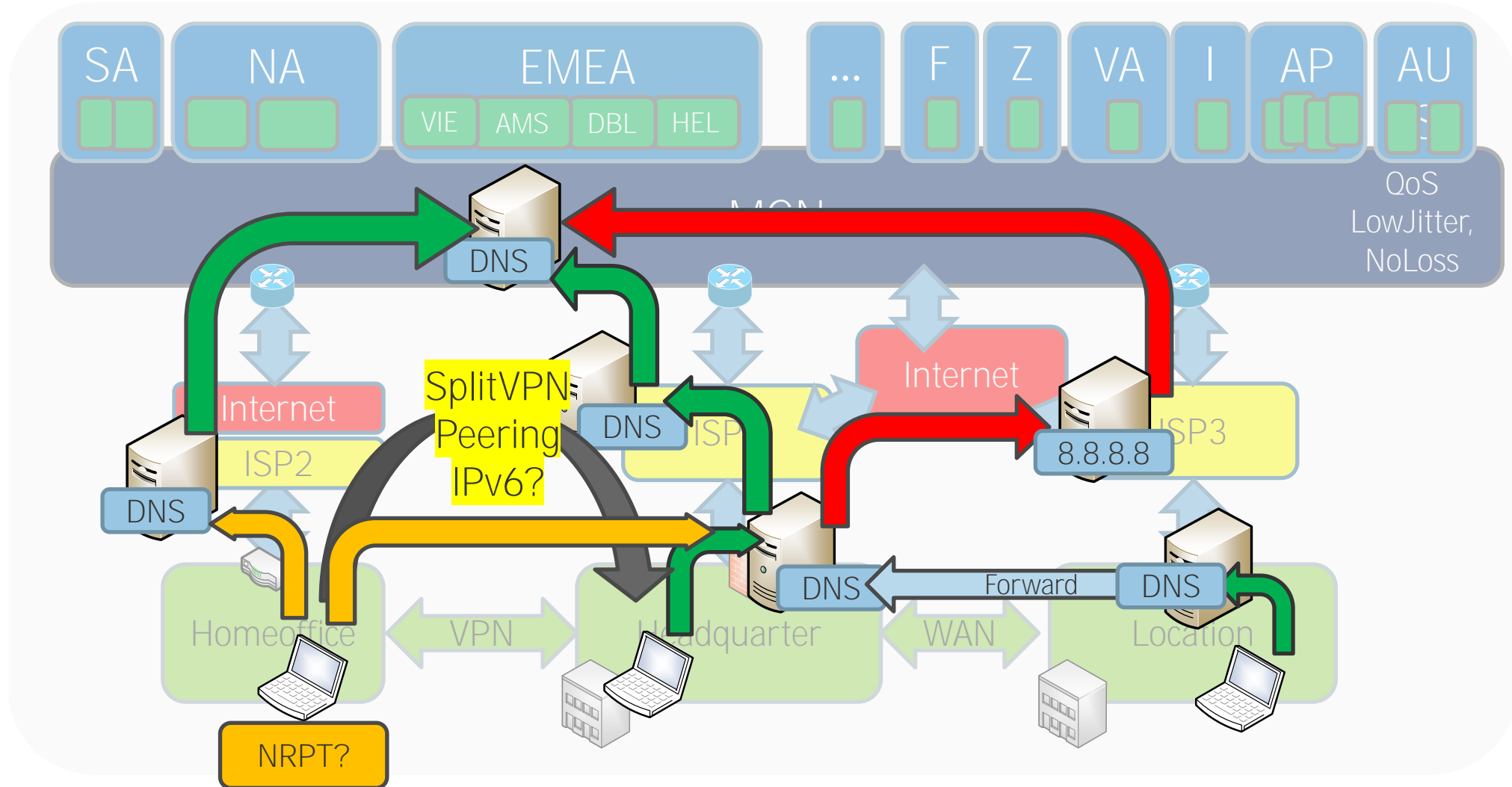

Öffentliche Nameserver

DNS-Server aus Brasilien

The table below is limited to the 100 recently checked servers.

IPv4/IPv6 Adresse	Standort	Software / Version	zuletzt überprüft	Status	Reliability	Whois
201.48.108.106 mail.suporterei.com.br.	Indaiatuba		vor 6 Stunden	✔ gültig	100 %	Whois
200.195.174.67 mail.whbbrasil.com.br.	Curitiba	dnsmasq-2.79	vor 6 Stunden	✔ gültig	100 %	Whois
200.155.74.15 a-mail.mopen.com.br.			vor 6 Stunden	✔ gültig	99 %	Whois
201.30.92.45 win.dataseek.com.br.			vor 6 Stunden	✔ gültig	84 %	Whois
200.212.2.125 checkout0.aslanet.com.br.			vor 6 Stunden	✔ gültig	100 %	Whois
45.227.59.227	Sao Vicente	9.10.3-P4-Ubuntu	vor 6 Stunden	✔ gültig 🔒	99 %	Whois
45.227.59.226	Sao Vicente	9.10.3-P4-Ubuntu	vor 6 Stunden	✔ gültig 🔒	99 %	Whois
200.159.11.202 200-159-11-202.customer.tdatabrasil.net.br.	São Paulo		vor 6 Stunden	✔ gültig	95 %	Whois
45.7.216.13	Caucaia		vor 6 Stunden	✔ gültig	100 %	Whois

Beispiel falscher DNS-Server

```
C:\>nslookup outlook.office.com
Server: home1.bellatlant.net
Address: 199.45.32.43
```

```
Nicht autorisierende Antwort
Name: MNZ-efz.ms-acdc.com
Addresses: 2603:1036:302:1::1
```

```
C:\>tracert 52.96.87.210
```

Routenverfolgung zu 52.96.87.210 über maximal 30 Hops

1	2 ms	1 ms	1 ms	fritz.box [192.168.178.1]
2	5 ms	4 ms	5 ms	p3e9bf2dc.dip0.t-ipconnect.de [62.155.242.220]
3	12 ms	11 ms	12 ms	d-ed5-i.D.DE.NET.DTAG.DE [62.154.5.213]
4	12 ms	12 ms	12 ms	80.157.204.58
5	16 ms	15 ms	16 ms	ae18.cr3-ams1.ip4.gtt.net [213.200.117.218]
6	16 ms	16 ms	16 ms	ip4.gtt.net [154.14.37.246]
7	16 ms	16 ms	16 ms	ae25-0.icr01.ams21.ntwk.msn.net [104.44.239.75]
8	97 ms	96 ms	96 ms	be-100-0.ibr01.ams21.ntwk.msn.net [104.44.22.235]
9	97 ms	96 ms	96 ms	be-8-0.ibr01.dub08.ntwk.msn.net [104.44.19.212]
10	97 ms	96 ms	96 ms	be-7-0.ibr01.sxl71.ntwk.msn.net [104.44.16.116]

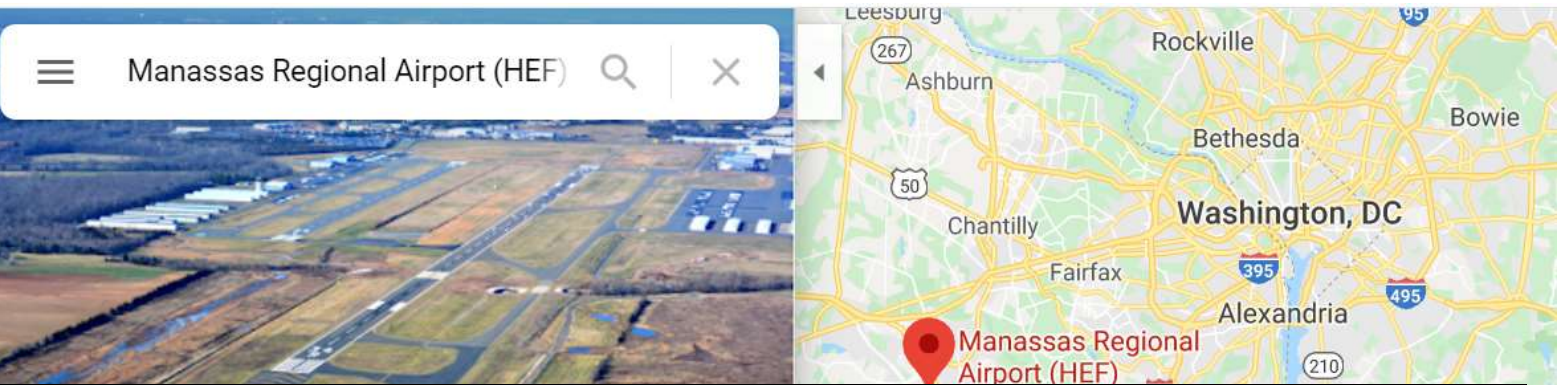

DNS Round Robin / TTL

```

PowerShell 7 (x64)
PS C:\> Get-DnsClientCache outlook.office365.com | ft -AutoSize

```

Entry	RecordName	RecordType	Status	Section	TimeToLive	Data
outlook.office365.com	outlook.office365.com	CNAME	Success	Answer	2	outlook.ms-acdc.office.com
outlook.office365.com	outlook.ms-acdc.office.com	CNAME	Success	Answer	2	FRA-efz.ms-acdc.office.com
outlook.office365.com	FRA-efz.ms-acdc.office.com	AAAA	Success	Answer	2	2603:1026:200:63::2
outlook.office365.com	FRA-efz.ms-acdc.office.com	AAAA	Success	Answer	2	2603:1026:207:131::2
outlook.office365.com	FRA-efz.ms-acdc.office.com	AAAA	Success	Answer	2	2603:1026:207:cd::2
outlook.office365.com	outlook.office365.com	CNAME	Success	Answer	8	outlook.ms-acdc.office.com
outlook.office365.com	outlook.ms-acdc.office.com	CNAME	Success	Answer	8	FRA-efz.ms-acdc.office.com
outlook.office365.com	FRA-efz.ms-acdc.office.com	A	Success	Answer	8	40.101.19.162
outlook.office365.com	FRA-efz.ms-acdc.office.com	A	Success	Answer	8	40.101.121.34
outlook.office365.com	FRA-efz.ms-acdc.office.com	A	Success	Answer	8	40.101.80.2

- Exchange Online
 - > outlook.office365.com ist CNAME auf outlook.ms-acdc.office.com
 - > outlook.ms-acdc.office.com ist CNAME auf <region>.ms-acdc.office.com
 - > <region>.ms-acdc.office.com verweist auf mehrere A-Records
 - > Alle Einträge haben einen sehr kurzen TTL

- Teams Media Relay „worldaz.tr.teams.microsoft.com“
 - > TTL=0!
 - > Viele Regionen, viele Server
 - > https://www.msxfaq.de/teams/admin/teams_transport_relay.htm

Anycast DNS mit IP-Routing Redundanz im Internet

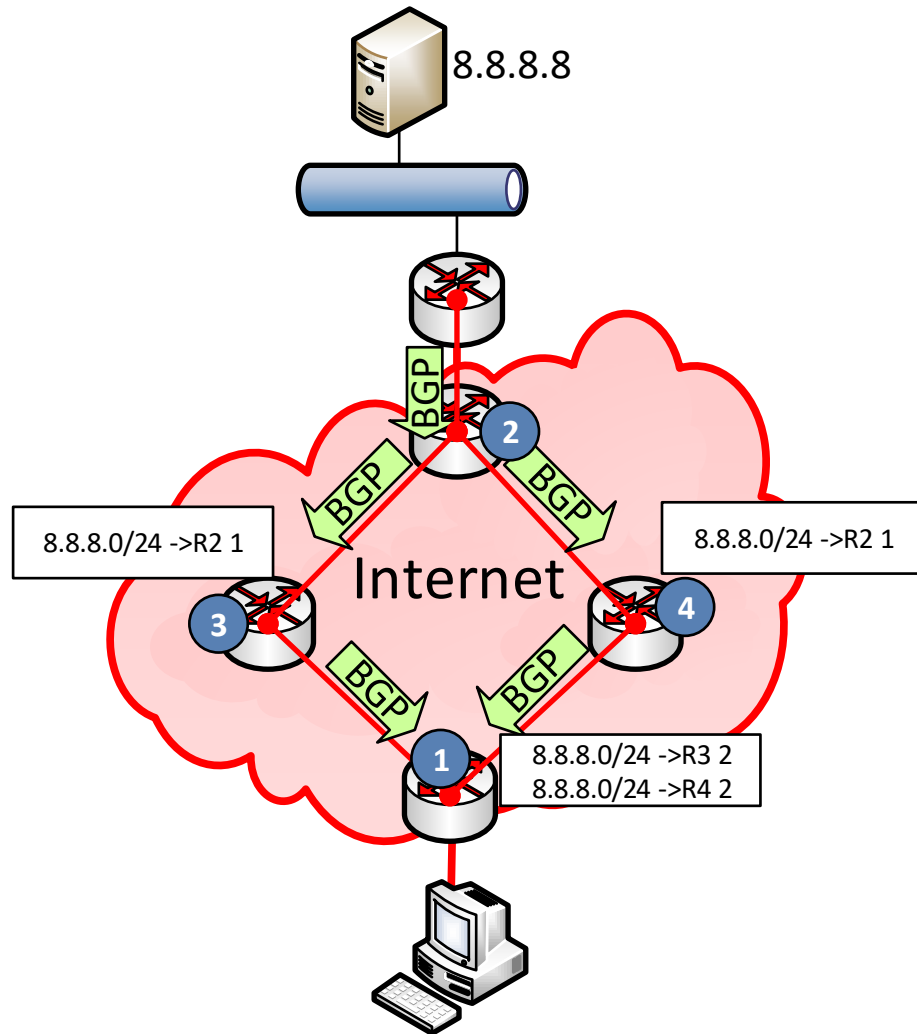

Redundanz beim Anbieter

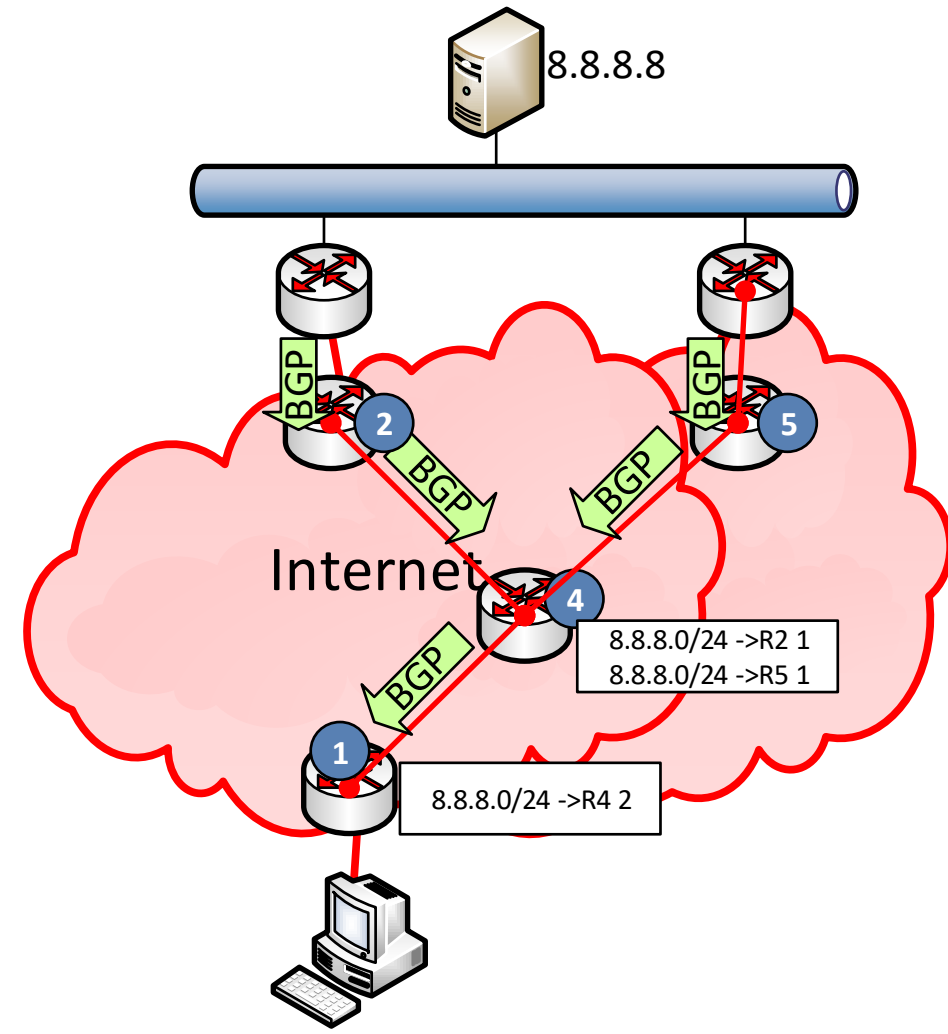

Anycast DNS mit Office 365

Mildert DNS-Fehlkonfigurationen ab

- Identische Services
- Verschiedene Standorte
- „Nächster Zugang“ per BGP
- Kein Geo-DNS erforderlich
- Hohe Verfügbarkeit
- Hohe Skalierbarkeit

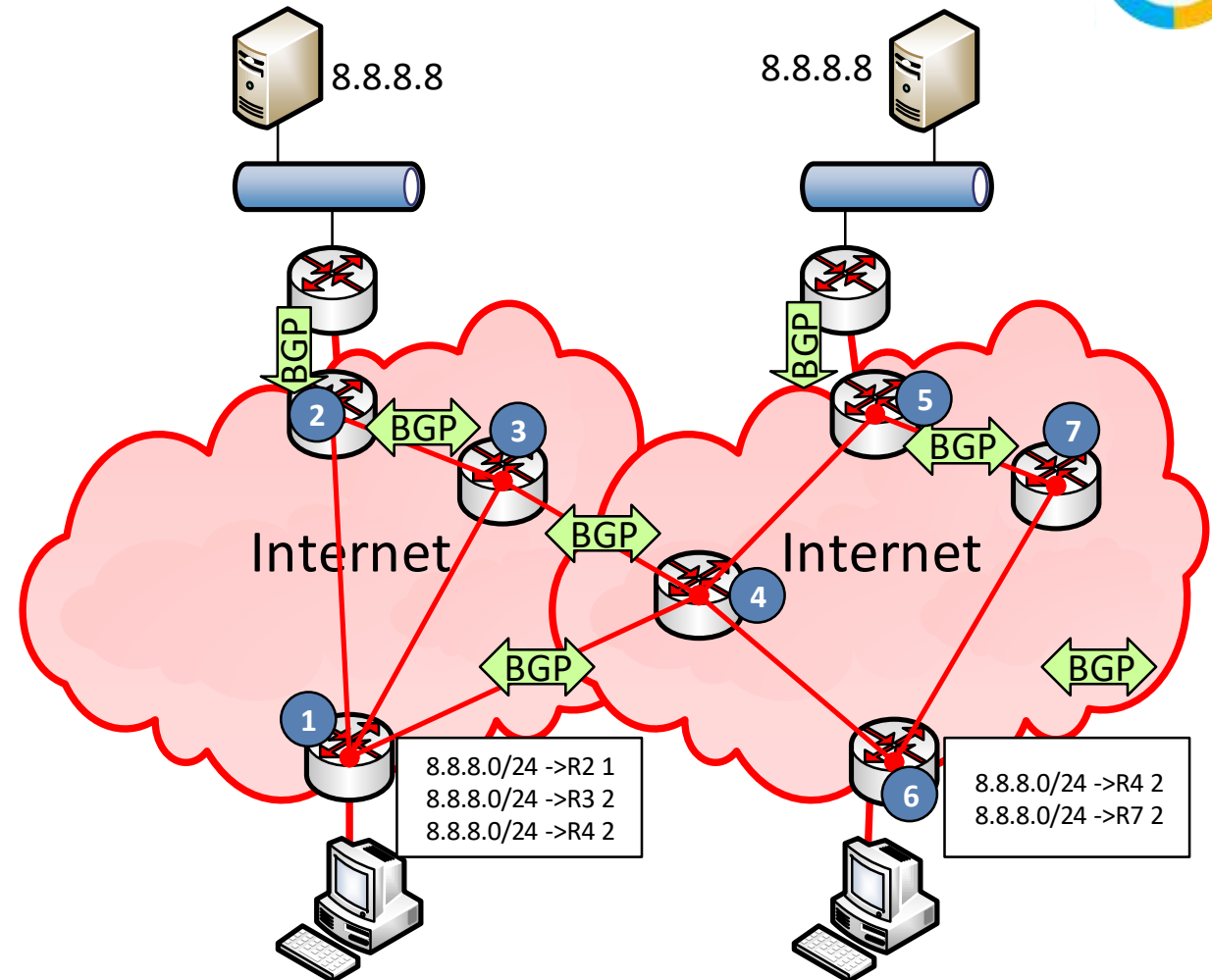



DNS by Service (Stand Apr 2022)

	Name	IP	Target
Exchange Online	GeoDNS outlook.office365.com AnyCast-DNS (partiell) outlook.office.com	AMS-efz.ms-acdc.office.com FRA-efz.ms-acdc.office.com LHR-efz.ms-acdc.office.com SFX-efz.ms-acdc.office.com SJC-efz.ms-acdc.office.com CPQ-efz.ms-acdc.office.com	Unterschiedliche Adressen
SharePoint/OneDrive	Anycast DNS <tenant>.sharepoint.com <tenant>-my.sharepoint.com	spo-0004.spo-msedge.net	13.107.136.9
Teams HTTP	Anycast DNS teams.microsoft.com	s-0005.s-msedge.net o.a.	52.113.194.132 2620:1ec:42::132
Teams RTP	GeoDNS worldaz.tr.teams.microsoft.com	Abhängig von der Region	13.107.64.0/18 52.112.0.0/14 52.120.0.0/14
SfB Online	Kein DNS-Name	IP-Adressen über SDP Inband-Provisioning	13.107.64.0/18 52.112.0.0/14 52.120.0.0/14





Optimierung nach Microsoft 365 Zielen

		Dienste und URLs
Optimieren <ul style="list-style-type: none">• Exchange• SharePoint• OneDrive• Teams	<ul style="list-style-type: none">• Viel Volumen• Kritische Latenzzeit• Hohe Last• Keine Authentifizierung• Keine SSL Inspection• Ohne Proxy	<ul style="list-style-type: none">• URL: outlook.office365.com:443 (Outlook)• URL: outlook.office.com:443 (OWA)• URL: <tenant>.sharepoint.com:443 (SharePoint)• URL: <tenant>-my.sharepoint.com:443 (Personal OneDrive)• URL: teams.microsoft.com:443• Teams UDP 3478-3481 (Audio/Video) (13.107.64.0/18, 52.112.0.0/14, 52.120.0.0/14)
<ul style="list-style-type: none">• EVOSTS	<ul style="list-style-type: none">• Anmeldung, MFA, CA	<ul style="list-style-type: none">• Sonderfall mit VPN und Source-IP der Firma (Bypass Zscaler!)
Erlaubt (Partner)	<ul style="list-style-type: none">• Proxy möglich• Weniger Last	<ul style="list-style-type: none">• Andere Tenants (*.sharepoint.com)• Office Telemetry, Office Activation• Low Volume Dienste (Flow, Delve etc.)• ...
Rest (Internet)	<ul style="list-style-type: none">• SSL Inspektion• Virenschutz• Authentifizierung• Jugendschutz	<ul style="list-style-type: none">• Partner• Allgemeines Internet• Malware-Sites

Aktuelle Adressen/URLs: <http://aka.ms/ipurlblog> und <http://aka.ms/ipurlws> BGP-ASN:8075 <https://bgpview.io/asn/8075>
<https://endpoints.office.com/endpoints/worldwide?noipv6&ClientRequestId=b10c5ed1-bad1-445f-b386-b919946339a7>
Office 365 Connectivity Guidance https://docs.microsoft.com/en-us/archive/blogs/onthewire/_guidance

TCP Level 400

- Windows Size
- Port-Limits
- TCP-Chimney
- Window size / RSS
- SACK



Big Fat Pipe Problem und Latenzzeit

- 1x PC + 1x Server
 - > CPU unlimited
 - > Disk unlimited
 - > LAN Unlimited
- 1x WAN-Link
 - > „Unlimited“ Bandwidth
 - > 20ms Roundtrip Time



Quiz: Welchen Durchsatz kann ich per FTP erreichen ?

- Bis 1 MBit
- 1-10 MBit
- 10-100 MBit
- >100 MBit

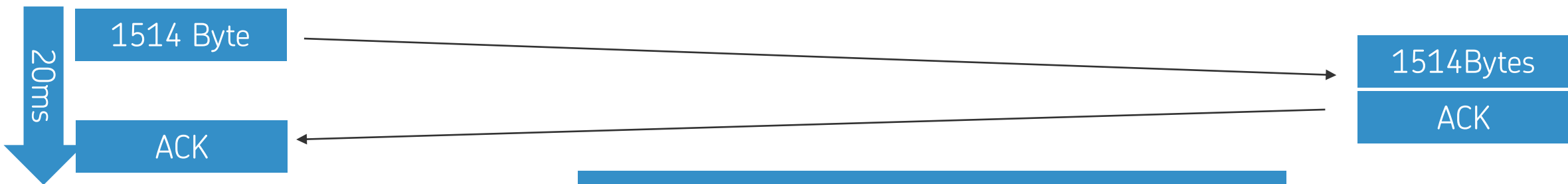

$50 \text{ packets} * 1514 \text{ bytes} = 75 \text{ kByte/Sec}$



Windows Scaling und Latenz

- **Sende mehr Pakete als Block und ACK verzögert**
 - › Sender und Empfänger müssen Puffer vorhalten
z.B. um verlorene Pakete neu zu senden und im Ziel zusammzusetzen
 - › Aushandlung des Buffers erforderlich (max. 1 GB, Win2008: 16MB)
 - › „RFC1323 TCP Extensions for High Performance“
 - › Selective Ack (SACK)

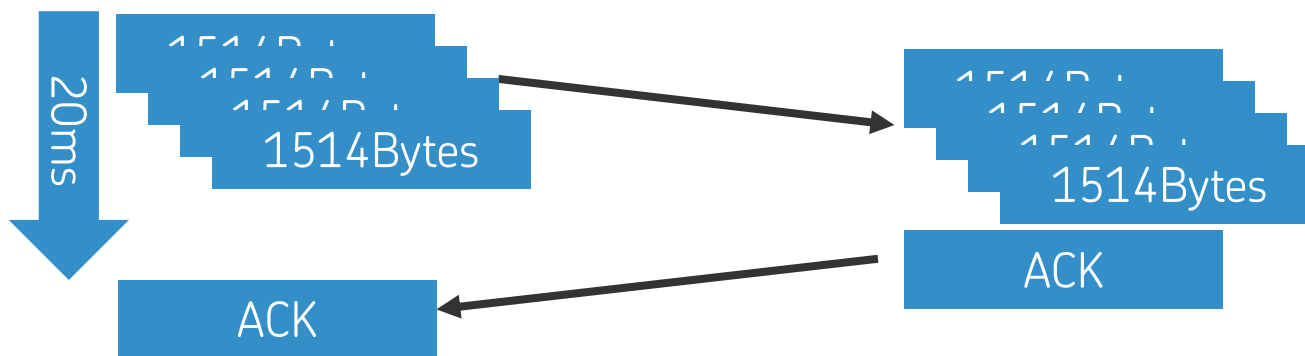

[https://docs.microsoft.com/en-us/previous-versions/technet-magazine/cc162519\(v=msdn.10\)](https://docs.microsoft.com/en-us/previous-versions/technet-magazine/cc162519(v=msdn.10))
https://www.msxfaq.de/netzwerk/grundlagen/tcp_retransmit_und_sack.htm

```

> Frame 885: 271 bytes on wire (2168 bits), 271 bytes captured
> Ethernet II, Src: Portwell_49:4f:68 (00:90:fb:49:4f:68), Dst
> Internet Protocol Version 4, Src: 40.97.134.18, Dst: 192.168
  > Transmission Control Protocol, Src Port: 443, Dst Port: 4987
    Source Port: 443
    Destination Port: 49870
    [Stream index: 28]
    [TCP Segment Len: 217]
    Sequence number: 5544 (relative sequence number)
    [Next sequence number: 5761 (relative sequence number)]
    Acknowledgment number: 2783 (relative ack number)
    0101 .... = Header Length: 20 bytes (5)
  > Flags: 0x018 (PSH, ACK)
    Window size value: 65535
    [Calculated window size: 1048560]
    [Window size scaling factor: 16]
    Checksum: 0x8fa4 [unverified]
    [Checksum Status: Unverified]
  
```

Windowsize und Latenz = Durchsatz

Applikation	Windowsize	1ms	20ms	50ms	100ms	200ms
Exchange Webservices (EWS)	1.048.560	na	50MB/s	20MB/s	10MB/s	5MB/s
OneDrive 10MB Upload	1.059.840	na	50MB/s	20MB/s	10MB/s	5MB/s
SharePoint 12MB Download	4.273.920	na	208MB/s	84MB/s	42MB/s	21MB/s
End2end-http Outlook	1.588.480	na	75MB/s	30MB/s	15MB/s	7,5MB/s
Outlook Client	525.568	na	25MB/s	10MB/s	5MB/s	2,5MB/s
SFTP using SSH 1and1	131584	na	6MB/s	2,4MB/s	1,2MB/s	660kB/s
SMB im LAN	2.102.272	GB+	na	na	na	na

Das sind „gemessene Wert“. Aber prüft die effektive Windowsize? Spielverderber Firewall

Paket Loss und Durchsatz

- Gründe für Paketverlust
 - › Queue-Überlauf
 - › Link-Congestion
- TCP-Reaktion
 - › Drosselung der Senderate
 - › TCP Retransmit
- VoIP
 - › RTCP-Meldung
 - › Bitraten-Anpassung
 - › Codec-Anpassung

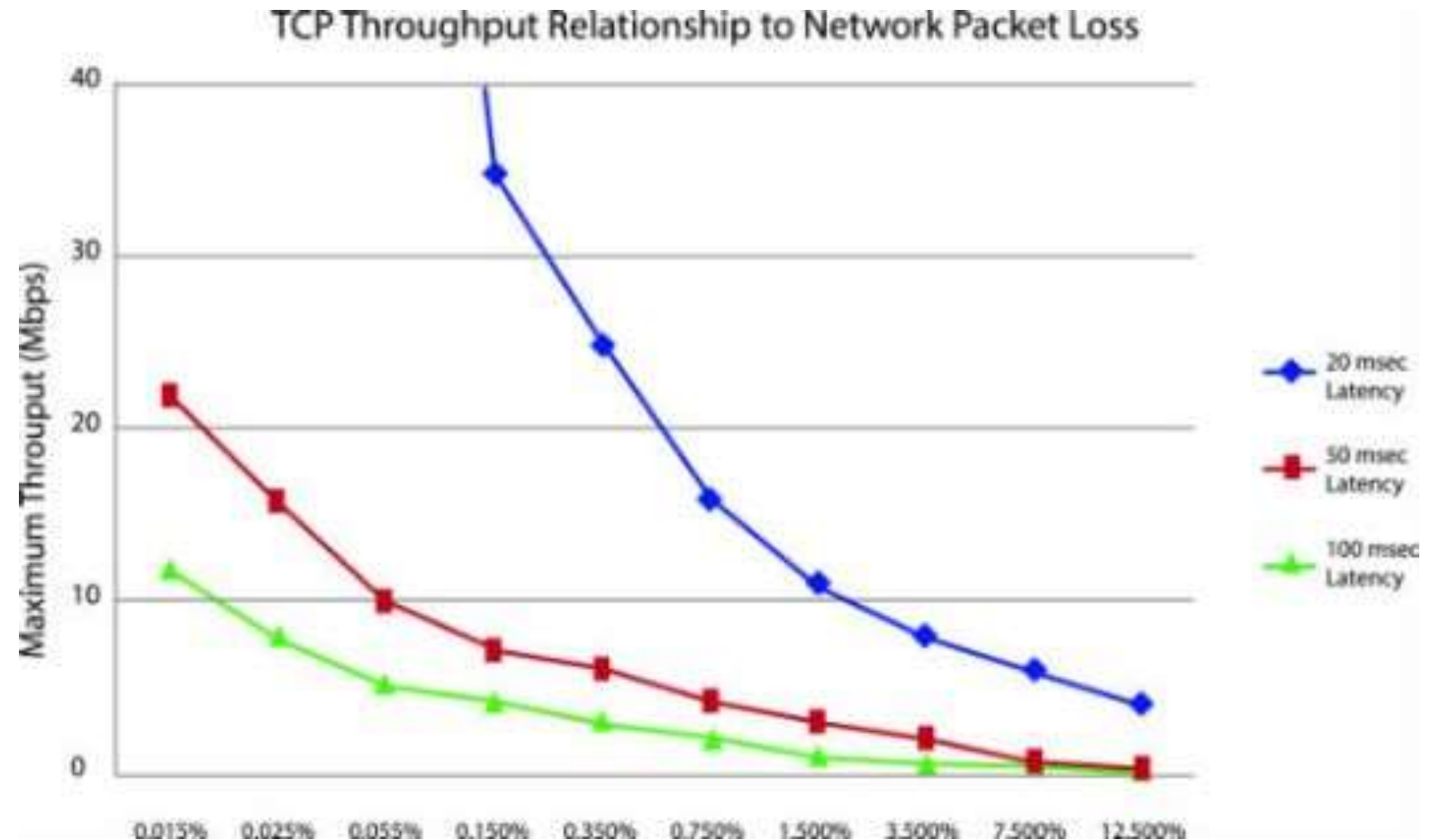

Source: <https://telnetnetworks.wordpress.com/tag/packet-loss/>



Latenz ist pro Connection -> viele Connections

- Beispiel Outlook
- Beispiel Teams

Outlook-Verbindungsstatus

Allgemein Lokales Postfach

Aktivität

VID	SMTP-Adresse	Servername	Status	Proto...	Authn	Verschl...	Typ	Anfr/Fehle
6	Frank.Carius@Netat...	https://outlook.office365.com/...	hergestellt	HTTP	Träger*	SSL	Exchange-Verzei...	60/3

TCP-Verbindungen

Gefiltert von "OUTLOOK.EXE, Teams.exe, Teams.exe"

Prozess	PID	Lokale Adresse	Lokale...	Remoteadresse	Remoteport	Paketverlust (%)	Latenz (ms)	Status	Proto...	Authn	Verschl...	Typ	Anfr/Fehle
Teams.exe	14412	172.18.241.38	58440	52.114.128.13	443	0	414	hergestellt	HTTP	Träger*	SSL	Exchange-Verzei...	60/3
Teams.exe	14412	172.18.241.38	58439	52.114.88.46	443	0	76	hergestellt	HTTP	Klartext*	SSL	Exchange-Verzei...	58/2
Teams.exe	13952	172.18.241.38	58447	52.114.74.39	443	0	74	hergestellt	HTTP	Träger*	SSL	Exchange-Verzei...	376/4
Teams.exe	14412	172.18.241.38	58457	52.178.94.2	443	-	-	hergestellt	HTTP	Klartext*	SSL	Exchange-Verzei...	63/2
Teams.exe	13952	172.18.241.38	58448	52.113.194.131	443	-	-	hergestellt	HTTP	Träger*	SSL	Exchange-E-Mail	3913/4
Teams.exe	14412	172.18.241.38	58435	52.113.194.131	443	-	-	hergestellt	HTTP	Nego*	SSL	Exchange-E-Mail	90/11
Teams.exe	13952	172.18.241.38	58417	52.114.76.35	443	-	-	hergestellt	HTTP	Träger*	SSL	Exchange-E-Mail	14711/6
OUTLOOK.EXE	22632	172.18.241.38	58520	40.101.12.18	443	0	1.190	hergestellt	HTTP	Träger*	SSL	Exchange-E-Mail	97/4
OUTLOOK.EXE	22632	172.18.241.38	58519	40.101.12.18	443	0	567	hergestellt	HTTP	Klartext*	SSL	Exchange-E-Mail	2470/6
OUTLOOK.EXE	22632	172.18.241.38	58507	40.101.12.18	443	0	553	hergestellt	HTTP	Träger*	SSL	Exchange-E-Mail	12/0
OUTLOOK.EXE	22632	172.18.241.38	58499	40.101.12.18	443	0	523						
OUTLOOK.EXE	22632	172.18.241.38	58517	40.101.12.18	443	0	491						
OUTLOOK.EXE	22632	172.18.241.38	58497	40.101.12.18	443	0	490						
OUTLOOK.EXE	22632	172.18.241.38	58493	40.101.12.18	443	0	461						
OUTLOOK.EXE	22632	172.18.241.38	58506	52.114.76.35	443	0	420						
OUTLOOK.EXE	22632	172.18.241.38	58487	40.101.12.18	443	0	397						
OUTLOOK.EXE	22632	172.18.241.38	58490	40.101.12.18	443	0	342						
OUTLOOK.EXE	22632	172.18.241.38	58485	40.101.12.18	443	0	318						
OUTLOOK.EXE	22632	172.18.241.38	58521	40.101.12.18	443	0	301						
OUTLOOK.EXE	22632	172.18.241.38	58510	40.101.12.18	443	0	272						
OUTLOOK.EXE	22632	172.18.241.38	58503	40.101.12.18	443	0	188						
OUTLOOK.EXE	22632	172.18.241.38	58486	40.101.12.18	443	0	186						
OUTLOOK.EXE	22632	172.18.241.38	58501	40.101.12.18	443	0	182						



TCP/IP und Ports

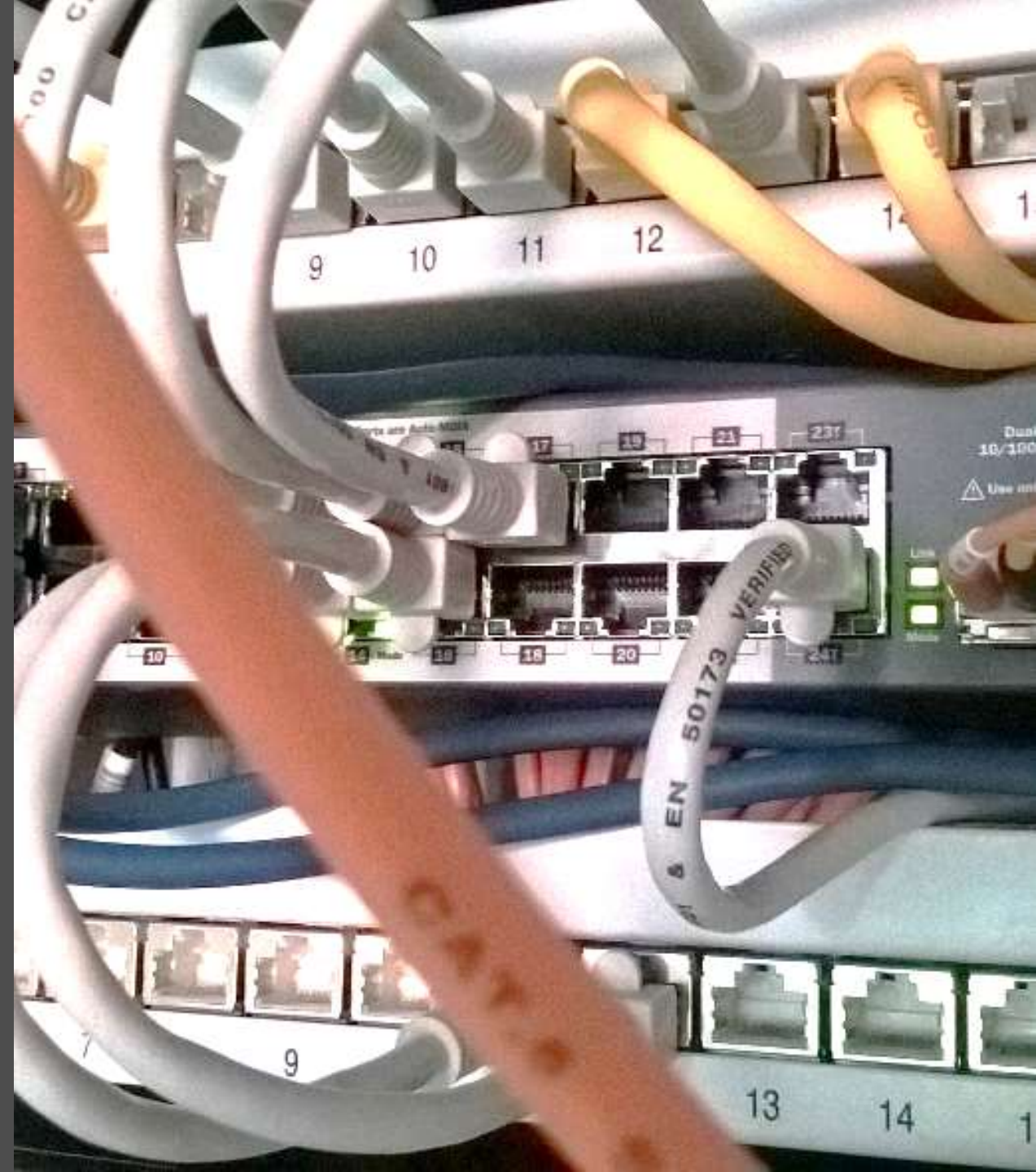

Private Adressen und öffentliche Ports

- Fakten

- > Internet nutzt öffentliche Adressen
- > Clients sind hinter privaten Adressen
- > IP-Translation erforderlich
- > Proxy und NAT
- > Cloud Proxy verlagert Problem

- Fragen:

- > Wie viele ausgehende Source-Port hat ein System?
- > Wie viele gleichzeitige Verbindungen macht ein Client ?
- > Wie viele Clients passen hinter eine öffentliche IP-Adresse?

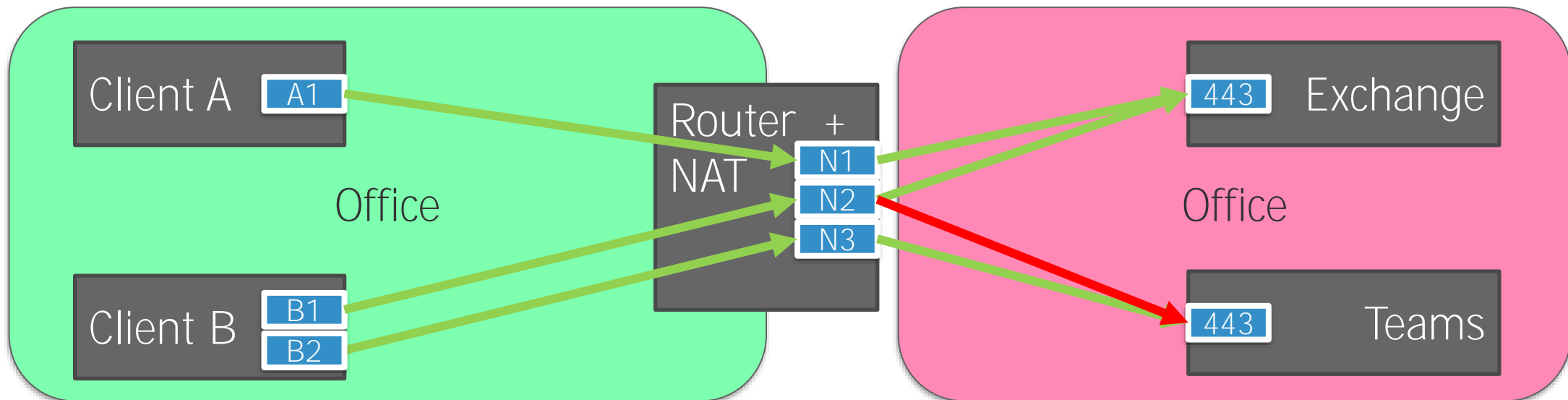

Private Adressen und öffentliche Ports

- Internet nutzt öffentliche Adressen
- Clients sind hinter privaten Adressen
- IP-Translation erforderlich
- Proxy und NAT sind die Komponenten
- Fragen:
 - > Wie viele ausgehende Source-Port hat ein System?
 - > Wie viele gleichzeitige Verbindungen macht ein Client ?
 - > Wie lange bleibt die Verbindung aktiv?
 - > Wie viele Clients passen hinter eine öffentliche IP-Adresse?

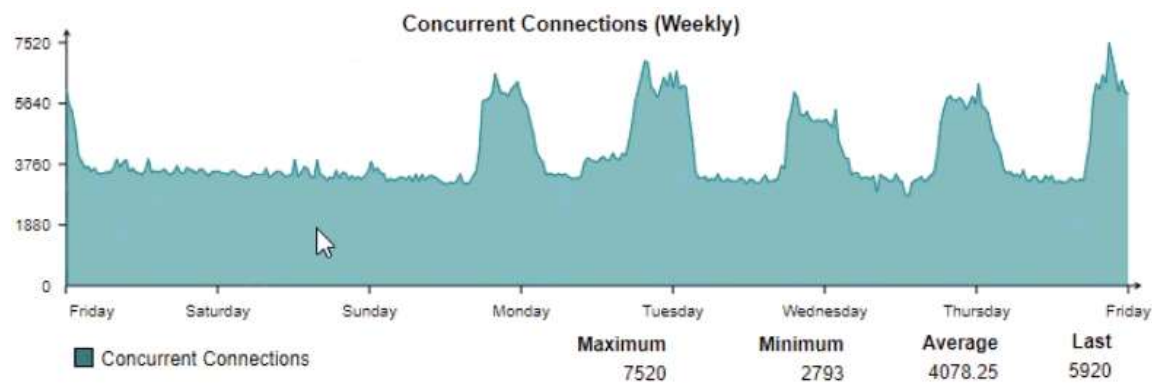

Quelle: Sophos UTM: Logging&Reporting / Networkusage

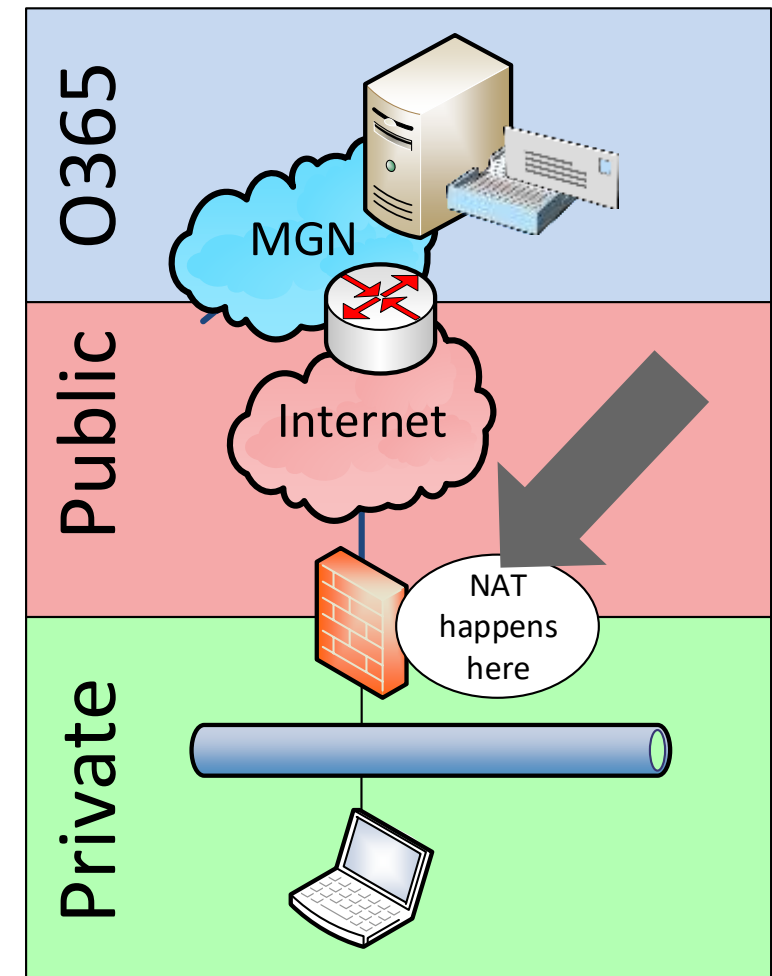

Session Timeout / Keepalive

- Jede Source IP hat maximal 65535 Ports frei
 - > Viele Clients -> Mehrere Source-IPs erforderlich
 - > Clients melden sich nicht „ab“
- NAT-Session
 - > Rückkanal für ausgehende Verbindungen
 - > Zuordnung PublicIP:Port -> PrivateIP:Port nicht ewig
- TCP Session Timeout
 - > Min 120 Sek... Auf allen Zwischenstationen
 - > „Push Verbindungen“ sind Pull mit später Antwort
 - > HTTP-Chunked-Verbindungen

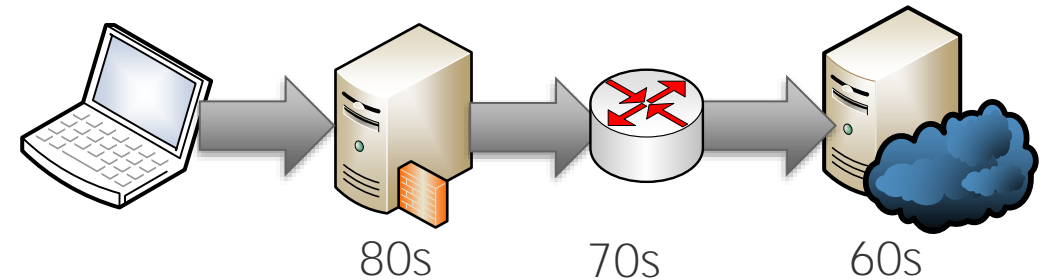

TCP keep-alives can be sent once every KeepAliveTime (defaults to 7,200,000 milliseconds or two hours) if no other data or higher-level keep-alives have been carried over the TCP connection.

<https://blogs.technet.microsoft.com/nettracer/2010/06/03/things-that-you-may-want-to-know-about-tcp-keepalives/>

https://www.msxfaq.de/netzwerk/grundlagen/tcp_session_timeout.htm

<https://blogs.technet.microsoft.com/onthewire/2014/03/04/network-perimeters-tcp-idle-session-settings-for-outlook-on-office-365/>



Microsoft Teams

- Chat
- Kollaboration
- Audio
- Video
- Content-Sharing
- Telefon



Microsoft Teams





Teams Workloads

Workload	Service
Login/Logoff/Presence	https:\\teams.microsoft.com
Chat (1:1, Groups, Channel, Federation)	https:\\teams.microsoft.com
Channel-Files	https:\\<tenant>.sharepoint.com
1:1 Files	https:\\<tenant>-my.sharepoint.com
Apps	https:\\<Application-URL>
1:1 Audio/Video/Sharing	UDP: RTP Client<->Client
Conference	UDP: RTP Client <-> MCU
Phone	UDP: RTP Client <-> SBC / Mediarelay



Warum UDP? - VoIP sind keine Daten

- **Klassischer Datenverkehr**
 - › Stoßweise, d.h. Anforderung und Antwort
 - › Keine Echtzeitübertragung
 - › TCP sichert Verluste und Reihenfolge
 - › Große Pakete (max. MTU-Size)
- **VoIP Audio/Video**
 - › Viele kleine Pakete, 20ms, 160 Bytes (=64kbit)
 - › Echtzeit, Kurze Laufzeiten
 - › Paket Loss: Nachsenden sinnlos
 - › Applikation muss Latenz, Jitter und Paketloss „sehen“
 - › Kann Codec, Bitrate, NB/WB, Auflösung anpassen
 - › „Artefakte“ bei Video, kurze Aussetzer bei Audio
 - › UDP ist das präferierte Protokoll
- **VoIP über TCP oder gar HTTPS**
 - › Datenverlust = Warten auf Nachlieferung
 - › Aussetzer in der Sprache
 - › „Stehendes Video“, längere Stille bei Audio

Kriterium	Daten	Audio/Video
Paketgröße	1500 kBytes	160 Bytes
Protokoll	TCP	UDP
Paketprofil	Stoßweise große Pakete	Kontinuierlich viele kleine Pakete
Paketverlust	TCP abgesichert	Nicht nachsenden
Reihenfolge	TCP abgesichert	Wenige ms
Adaption	Keine	Codec Auflösung WB/NB
Sicherheit	HTTPS/IPSEC	SRTP

Network Ready für VoIP

- **Signalisierung (SIP oder Https)**
 - > Port 443
 - > 5-10 kbit/User/Sek
 - > Unkritisch bezüglich Zeit
- **RTP Anforderungen**
 - > Client zu Office 365
 - > <https://aka.ms/sof-media-quality>
 - > Audio: 100kbit/Sek
- **Protokoll: UDP bevorzugt**
 - > TCP oder https sind schlecht!
 - > Quell-Port 50.000-50059
 - > Ziel-Port 3478-3481/UDP
- **Network Assessment**
 - > https://www.msxfaq.de/skype_for_business/tools/microsoft/skype_for_business_online_network_assessment_tool.htm

Metric	Edge	Client
Latency (one way)	< 30ms	< 50ms
Latency (RTT)	< 60ms	< 100ms
Burst packet loss	<1% during any 200 ms interval	<10% during any 200ms interval
Packet loss	<0.1% during any 15s interval	<1% during any 15s interval
Packet inter-arrival Jitter	<15ms during any 15s interval	<30ms during any 15s interval
Packet reorder	<0.01% out-of-order packets	<0.05% out-of-order packets

<https://docs.microsoft.com/de-de/skypeforbusiness/optimizing-your-network/media-quality-and-network-connectivity-performance#network-performance-requirements-from-your-network-edge-to-microsoft-network-edge>



Hinweis zu UDP 3478-3481 und TCP443

Firewall and proxy requirements

Microsoft Teams connects to Microsoft Online Services and needs internet connectivity for this. For Teams to function correctly, you must open TCP ports 80 and 443 from the clients to the internet, and UDP ports 3478 through 3481 from the clients to the internet. The TCP ports are used to connect to web-based content such as SharePoint Online, Exchange Online, and the Teams Chat services. Plug-ins and connectors also connect over these TCP ports. The four UDP ports are used for media such as audio and video, to ensure they flow correctly.

Opening these ports is essential for a reliable Teams deployment. Blocking these ports is unsupported and will have an effect on media quality.

Source: <https://docs.microsoft.com/en-us/microsoftteams/3-environment-evaluate-my-environment#firewall-and-proxy-requirements>



Google Meet Readiness

- Google nutzt 19302–19309/UDP 443/TCP
 - > Netzwerk auf Meet-Videoanrufe vorbereiten
<https://support.google.com/a/answer/1279090>
- Test mit ICMP
 - > 4h Dauer-PING
 - > Gegenstelle `lens.l.google.com`
 - > Immer <100ms
 - > Keine „Mittelwerte“
- TraceRoute
 - > „Kurze Strecke“ gefordert
- Bandbreite: Mit „Drittanbietertool“
- Oder WebRTC Troubleshooter
<https://test.webrtc.org/>

Audio- und Videoqualität verbessern

Latenz messen

Wenn Sie ein Problem mit der Videoqualität haben, überprüfen Sie zuerst, ob die Netzwerklatenz niedrig und konsistent ist. Die Videoqualität ist optimal, wenn der Meet-Datenverkehr den kürzesten Weg zwischen dem Client und Google nehmen kann. Am besten ist es, wenn die Paketumlaufzeit (Round Trip Time, RTT) zwischen dem Client und Google unter 100 ms liegt. Die Videoqualität von Meet wird reduziert, wenn die Latenz zu hoch ist, z. B. 300 ms oder mehr.

So können Sie die Latenz messen:

- Führen Sie das [Analysetool für die Netzwerklatenz](#) aus.
- Pingen Sie das Media-Front-End des Google Meet-Servers für mindestens vier Stunden an.

```
> ping lens.l.google.com
PING lens.l.google.com (74.125.143.127): 56 data bytes
64 bytes from 74.125.143.127: icmp_seq=0 ttl=47 time=25.424 ms
64 bytes from 74.125.143.127: icmp_seq=1 ttl=47 time=25.271 ms
64 bytes from 74.125.143.127: icmp_seq=2 ttl=47 time=26.262 ms
64 bytes from 74.125.143.127: icmp_seq=3 ttl=47 time=26.085 ms
64 bytes from 74.125.143.127: icmp_seq=4 ttl=47 time=26.219 ms
```

Die Latenz muss konstant bei 100 ms oder weniger liegen. Die Werte dürfen nicht im Durchschnitt ermittelt werden, da sonst Spitzen und zwischenzeitliche Latenzprobleme ausgeblendet würden.

Wenn die Latenz mehr als 100 ms beträgt, drücken Sie mit dem Tool "Traceroute" den Netzwerkpfad von Ihrem aktuellen Computer zum Media-Front-End von Meet aus. Der Pfad sollte so kurz wie möglich sein, z. B.:

```
> traceroute lens.l.google.com
```

Geben Sie auf Chromebooks Folgendes ein:

```
> tracepath lens.l.google.com
```

<https://support.google.com/a/answer/7582554#zippy=%2Cbandbreite-messen-und-optimieren%2Clatenz-messen>



Teams RTP 1:1 Teams Call / PSTN Call

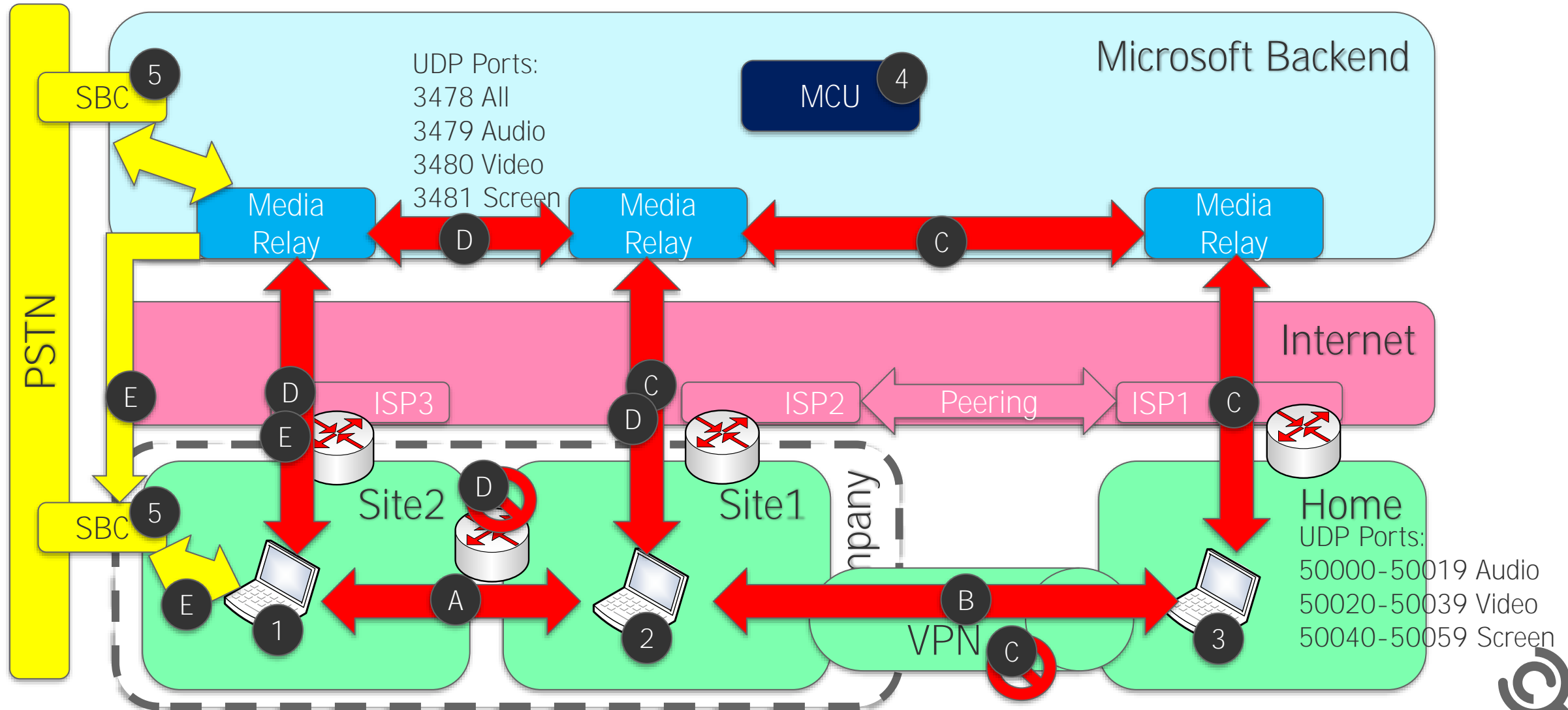

Teams RTP Meeting

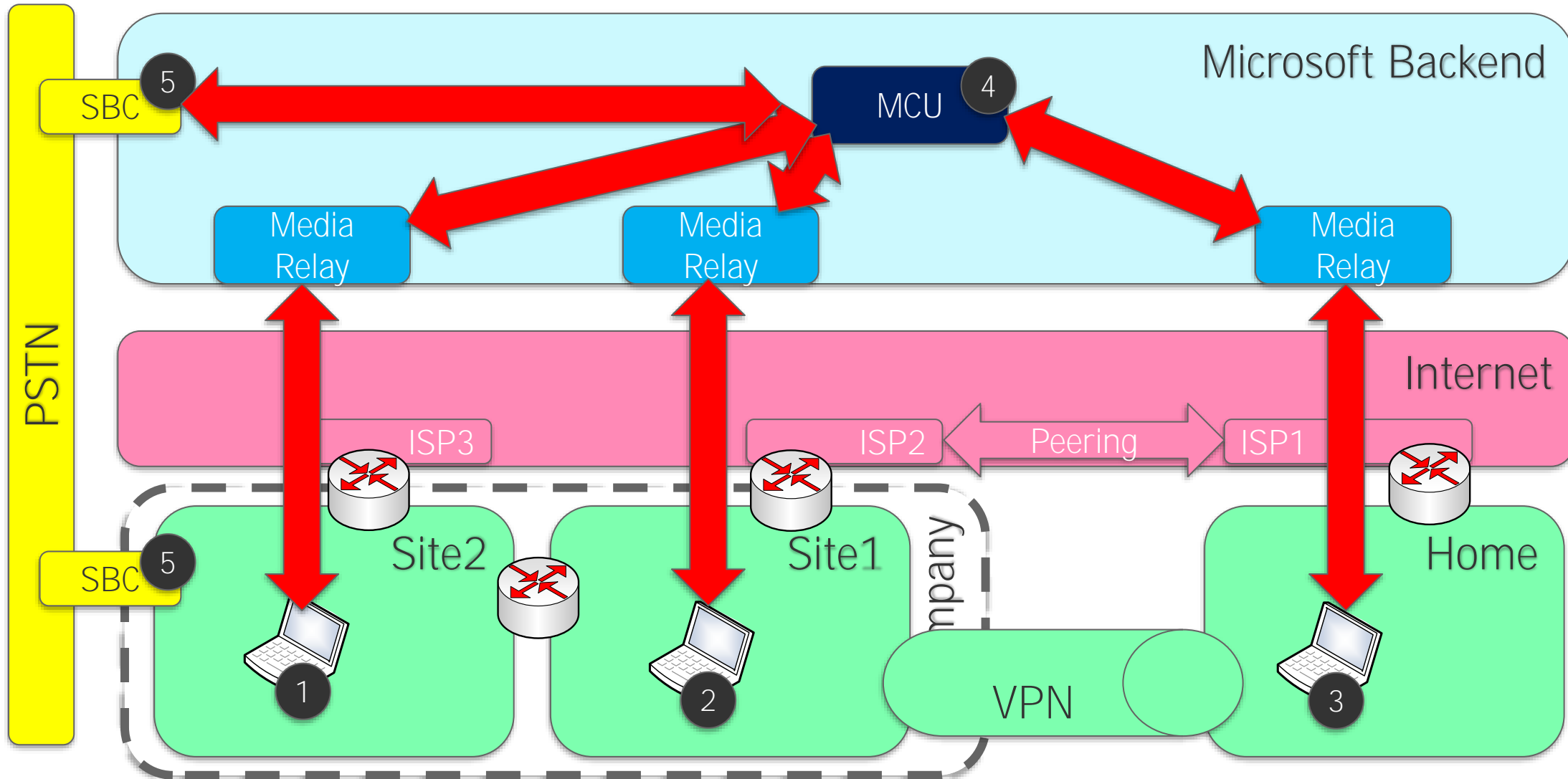



Typische Kennzahlen

Service	Bandbreite	Connections	Latenz	Bewertung
ADSync	Wenige Megabyte/Tag	30 Min HTTPS	Unkritisch	Kaum relevant
ADFS/PTA	Einige Kilobyte/User/Tag	HTTPS	<200ms	Kaum relevant
Outlook	4-8kbit/User/Sek	10-25 HTTPS Connections	<200ms	Sizing aber nicht zeitkritisch
Microsoft Teams Skype for Business	4-8kbit/User/Sek + 100kbit Audio/Sek + 1-2MBit Video/Sek	50+ UDP-Pakete/Sek	<100ms	Zeitkritisch, „Real Time Media“
SharePoint/OneDrive u.a.	TBD	TBD	TBD	Sizing!
Azure Services	TBD	TBD	TBD	TBD

Teams Sizing:

1000 User * 20% Concurrency Audio = 200 Calls @100kBit = 20 Mbit

50% Video per Conference = 100 Videostreams @2MBit = 200 Mbit

Nonstop, continuous, realtime,

Netzwerk messen

- Wo messen?
- Bandbreite
- Auslastung
- Paketverlust
- Latenz



Monitoring bisher

- 1 • Eigene LAN/WAN-Verbindung
 - > Bandbreite via SNMP
 - > NetFlow für Verkehrsverteilung
- 2 • Internet
 - > Bandbreite mittels SNMP
 - > Proxylogs/URL-Logs
- 3 • Server
 - > Perfmon
 - > IIS-Logs
 - > Eventlog
- 4 • Clients
 - > Limitiert
 - > Meist nicht gefordert

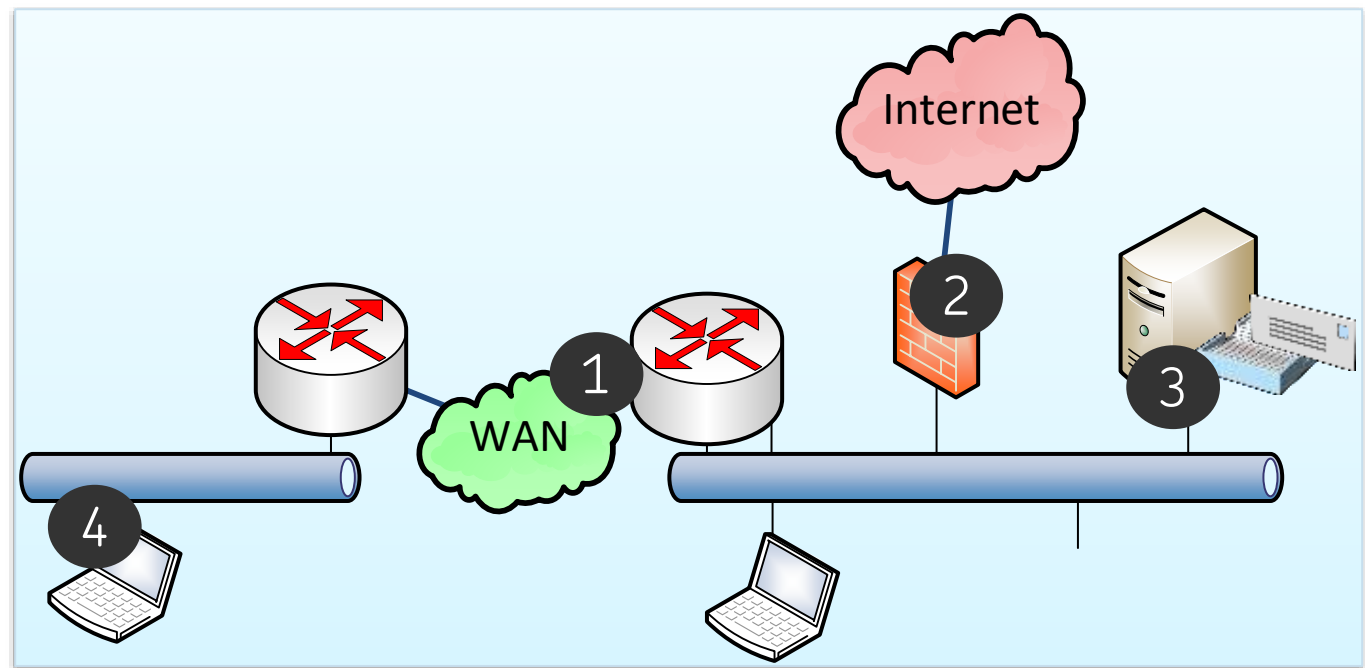

Alles ist unter Kontrolle.. Meistens...

Performance Monitoring mit Cloud

- Dienste sind in der Cloud
 - › Managed by Microsoft
- Kein lokaler Verkehr
 - › Lokaler Breakout
 - › Umgeht eigenes WAN
- Keine Daten vom ISP
- Deutlich mehr „Internet Traffic“
- Interne Links

1

2

3

4

5

Anpassung der Überwachung ist erforderlich

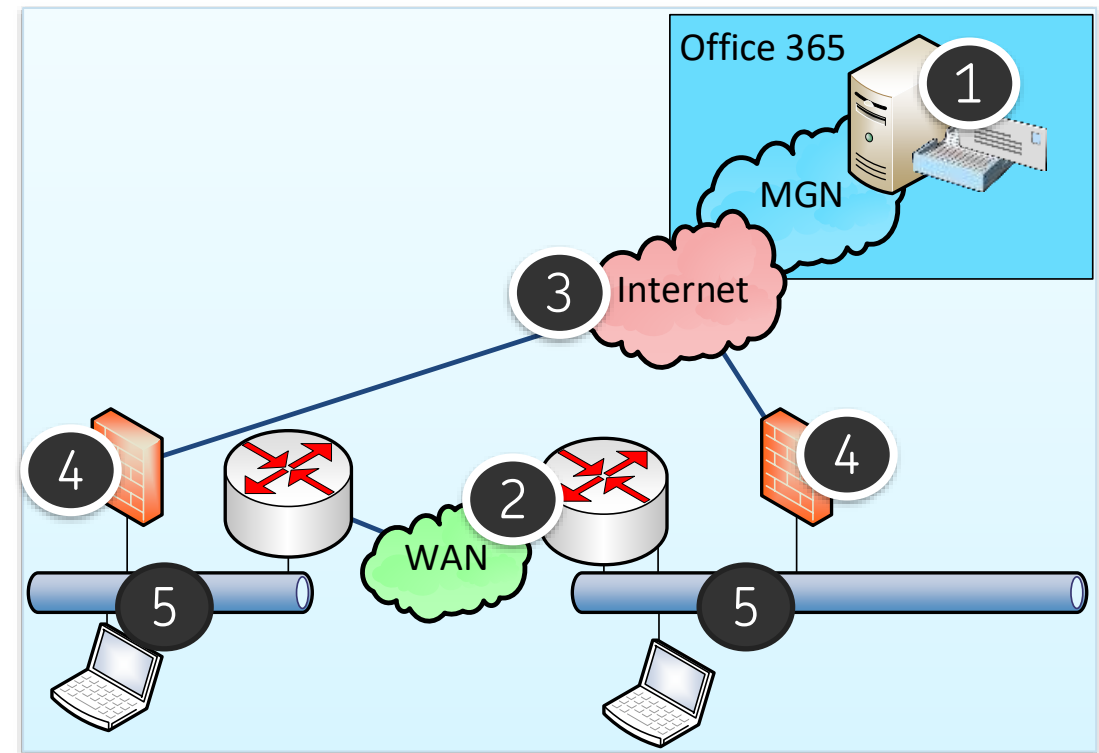

Bandbreite vs. Latenz

- NOC: Statement
 - > Unser Netzwerk ist schnell
 - > Nein, wir haben kein Bandbreitenproblem
- NOC: Monitoring per SNMP
 - > Messung jede Minute
 - > Trends bis zu 1 Jahr
- Aber!
 - > Datenmenge und Bandbreite sind gar nicht primär wichtig
 - > Latenzzeit ist viel wichtiger
 - > Wenig Bandbreite erkennt man auch an schlechterer Latenz

'Daily' Graph (5 Minute Average)

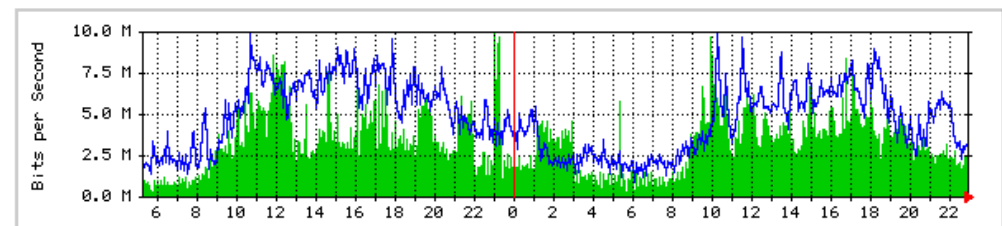

Max In: 9938.0 kb/s (9.9%) Average In: 3403.8 kb/s (3.4%) Current In: 1900.5 kb/s (1.9%)
 Max Out: 9946.0 kb/s (9.9%) Average Out: 4820.8 kb/s (4.8%) Current Out: 3306.9 kb/s (3.3%)

'Weekly' Graph (30 Minute Average)

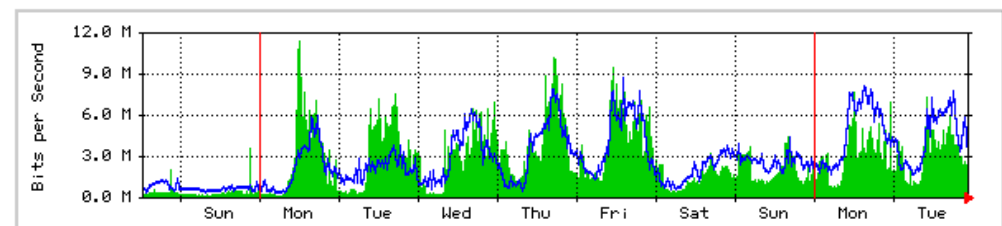

Max In: 11.4 Mb/s (11.4%) Average In: 2755.3 kb/s (2.8%) Current In: 2139.7 kb/s (2.1%)
 Max Out: 8678.4 kb/s (8.7%) Average Out: 2856.4 kb/s (2.9%) Current Out: 3002.0 kb/s (3.0%)

Frage: Wer misst heute schon "Latenzzeiten" im LAN/WAN?

Latenz und Stabilität richtig messen

- Wichtig ist, was beim Anwender ankommt!



Wie messen wir Latenzzeit?

- **Bandbreite**
 - › Anzahl der Fahrzeuge an einem Checkpoint
 - › Warteschlange am Checkpoint
- **Latenzzeit**
 - › Fahrzeit zwischen Start und Ziel
 - › „Real live“-Traffic
- **Messen**
 - › Aktiv: Eigene Tests
 - › Passiv: Performance Counter
 - › Kurze Abstände (< Sekunden)
 - › „Lückenlose“ Tests

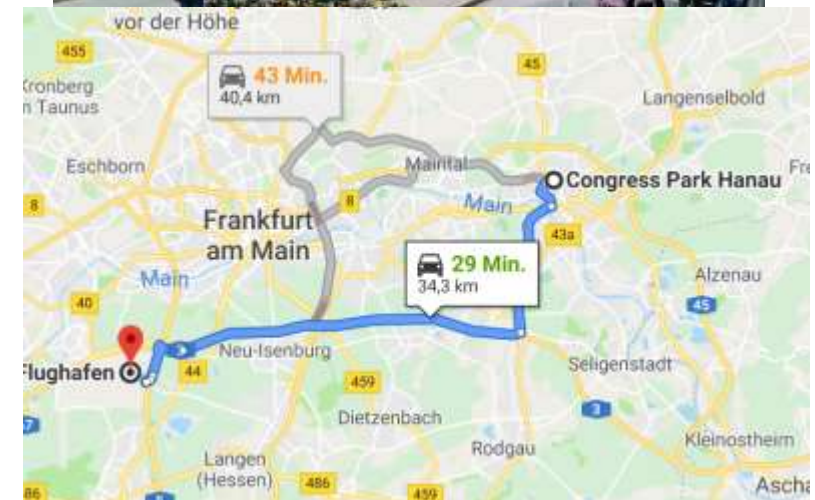

Häufige Fehler

- Latency vs. Bandwidth
 - › 80% Auslastung einer Leitung ist nicht generell schlecht
 - › Wenn die Latenzzeit ausreichend niedrig ist
 - › Hohe Latenzzeit bedeutet „nicht genug Bandbreite auf einer Teilstrecke“
- Zu große Messintervalle: Besser Sekunden vs. Minuten
 - › Es reicht nicht aus, einmal pro Minute zu messen
 - › RTP ist viel empfindlicher
 - › Sekunden oder sogar mehrfach pro Sekunde
- „Durchschnittswerte“ taugen nicht
 - › Wie sehen keine „Verteilung“, keine Spikes, keine Aussetzer
 - › Besser: Percentil oder Median

Was war nochmal Perzentil?

- Denken Sie an einen Pizza-Bringdienst
 - › Der Lieferant sagt: Im Mittel ist die Pizza nach 10 Min beim Kunden ist
 - › Klingt gut aber kann auch bedeuten
 - 50% der Pizzen werden nach 5 Minuten „super heiss“ angeliefert
 - 50% der Pizzen sind erst nach 15 Minuten und kalt
 - › -> 50% Unzufriedene Kunden
- Mittelwerte verschleiern schlechte Ergebnisse
 - › Keine Information über die Verteilung
- Besserer Ansatz
 - › Forderung: 95% der Pizzen werden „heiß genug“ geliefert
 - › -> max. 5% unzufriedene Kunden
- Das ist z.B. das „95% Perzentil“
 - › Die Zeit für 95% der Lieferungen



Google: “Make sure your latency is consistent at 100ms or less. Don't average the values because it can hide spikes and intermediate latency problems.”
 Quelle: <https://support.google.com/a/answer/7582554>

Was ist ein gültiges Protokoll?

- ICMP-Ping
 - > Psping, Ping,
 - > Traceroute
- TCP-Connect
 - > PSPing
- HTTP-Connect
 - > DNS-Query
 - > TLS-Handshake
- HTTP Download
 - > URL-Abfragen
 - > Content Size

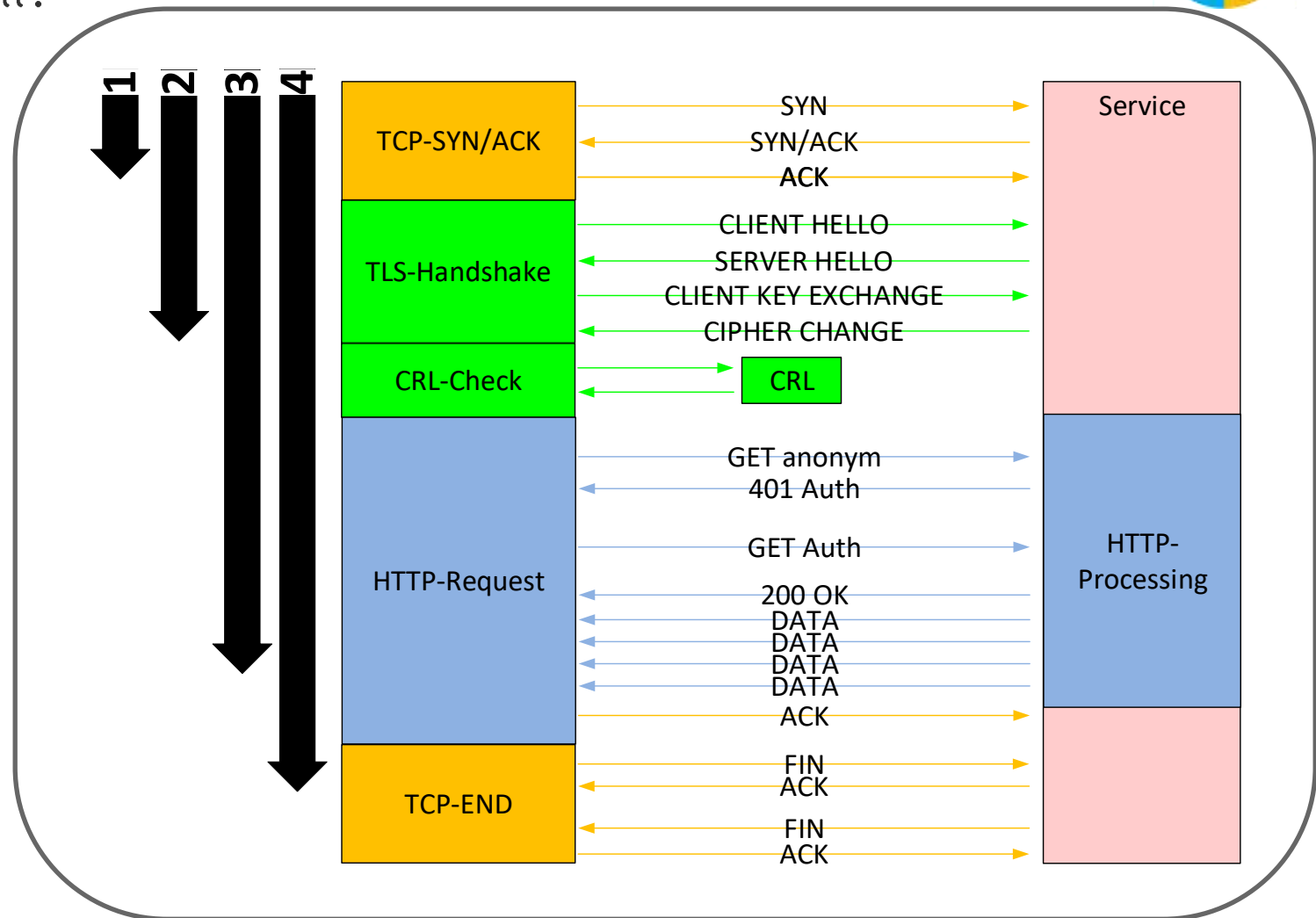



Demo

```
# Ping
(measure-command {
    Test-Connection
        -ComputerName outlook.office365.com
        -Count 1}
).totalseconds

# TCP Connect
(measure-command {
    Test-NetConnection
        -ComputerName outlook.office365.com
        -Port 443}
).totalseconds

# HTTP Request
(measure-command {
    invoke-webrequest http://outlook.office365.com/owa/favicon.ico | out-null}
).totalseconds
```

Die richtige Gegenstelle?

- Office 365 ist wichtig
- Überwachung der Hops
- Der Client ist wichtig
- Überwachung der Zwischenstationen

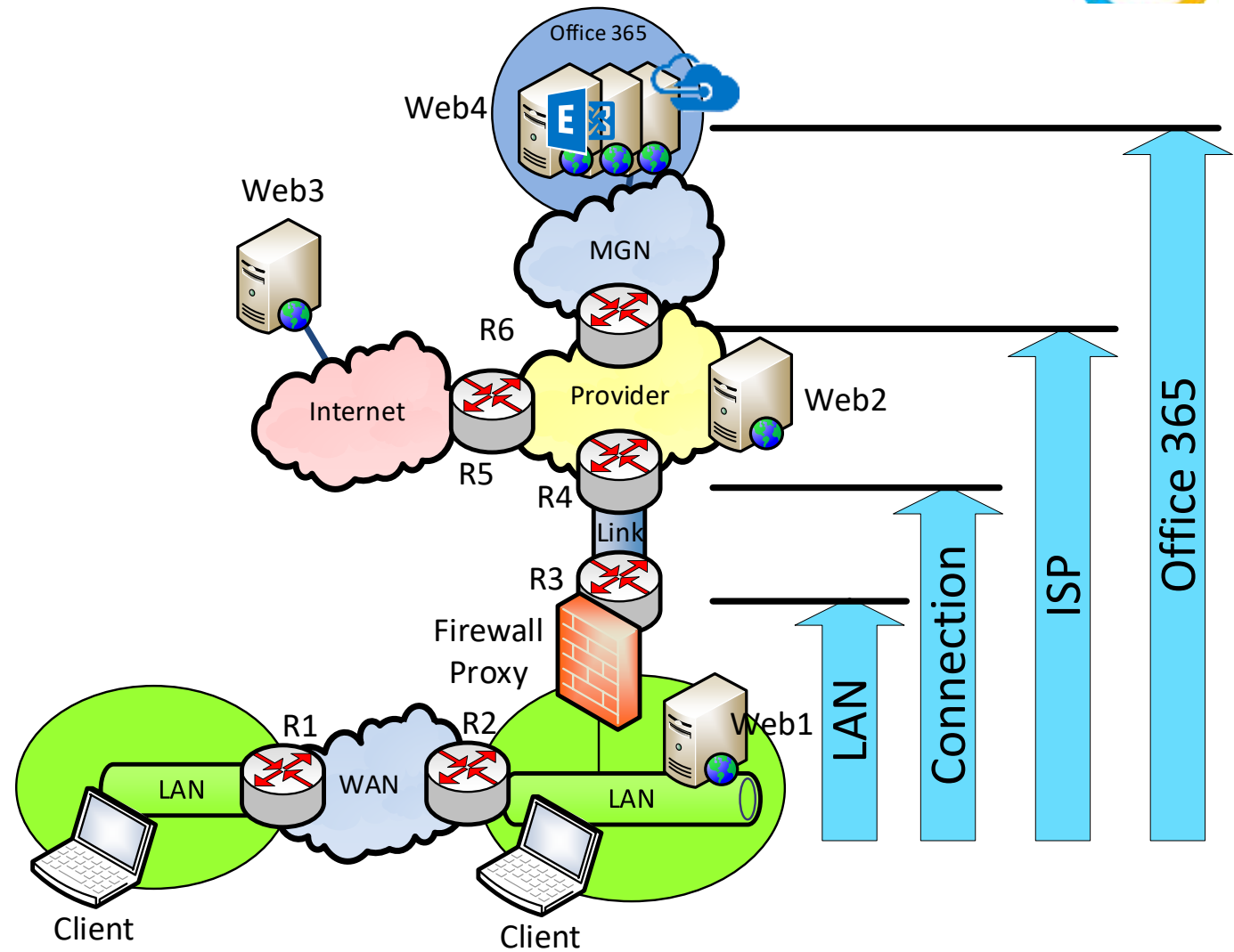

Wie nützlich ist PING ?

Eingabeaufforderung

```
>ping outlook.office365.com
```

```
ping wird ausgeführt für eat-efz.ms
```

```
Antwort von 40.97.205.2: Bytes=32 Z
```

```
Antwort von 40.97.205.2: Bytes=32 Z
```

```
Antwort von 40.97.205.2: Bytes=32 Z
```

```
Antwort von 40.97.205.2: Bytes=32 Z
```

```
ping-Statistik für 40.97.205.2:
```

```
Pakete: Gesendet = 4, Empfangen  
(0% Verlust),
```

```
Zeitangaben in Millisek.:
```

```
Minimum = 7ms, Maximum = 9ms, M
```

Beispiel: End2End-Ping

Bellevue Hotel 11:00pm/07:00am

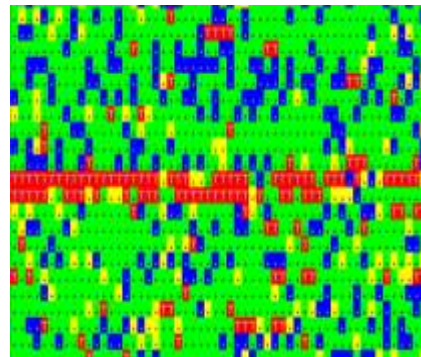
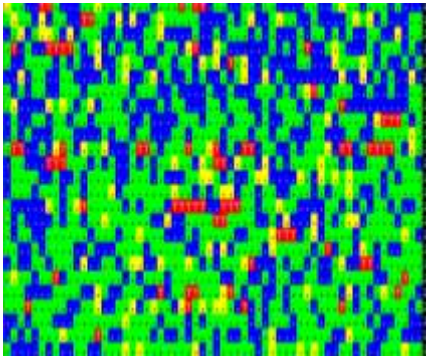

WifiOnICE

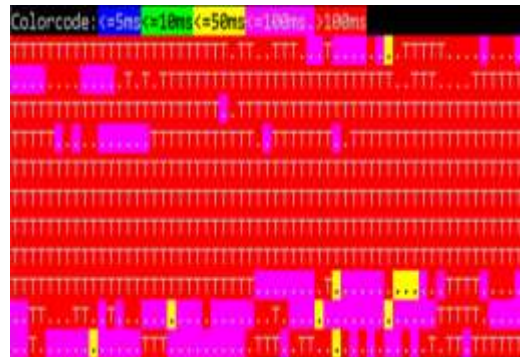

Home DSL 16/1

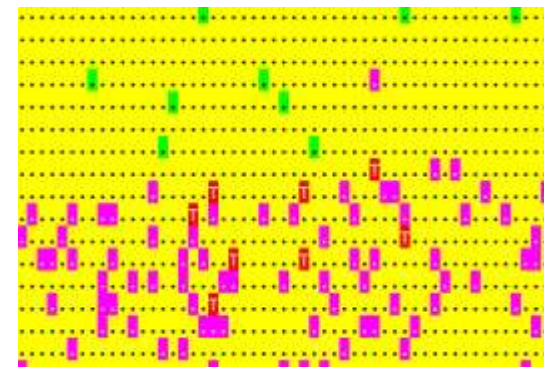

Hotel Frankfurt 01:00am, 07:00

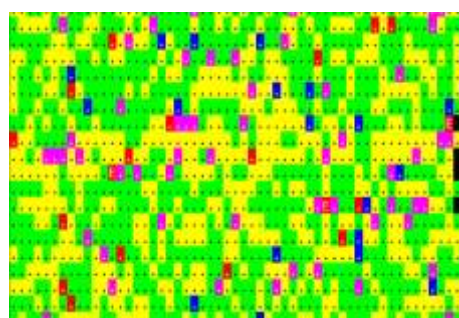
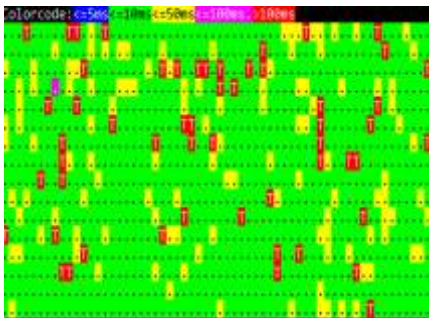

MSTFGuest (Internet / Office365)

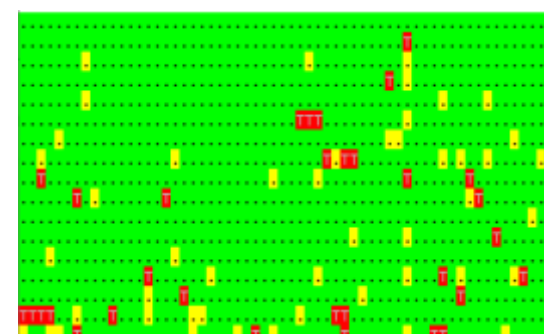
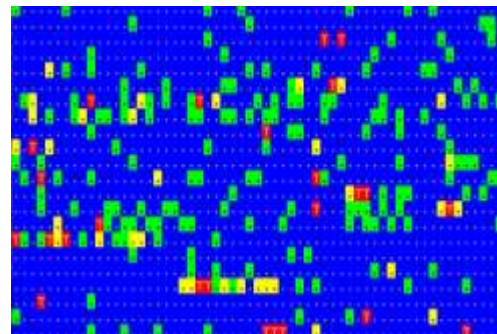



Latenzmessungen bei Providern

enterprise.verizon.com/terms/latency/



Wireless InHome Business

Solutions Products Resources Why Verizon

Home / Terms and Conditions / Latency Statistics

+1-877-297-7816



Verizon Enterprise Latency Statistics (ms)												
	2019											2018
	October	September	August	July	June	May	April	March	February	January	December	November
Trans Atlantic (90.000)	70.545	70.573	70.526	70.460	73.833	69.986	69.950	69.930	69.965	69.888	70.531	70.965
Europe (30.000)	11.901	11.452	11.459	11.194	10.978	11.706	11.234	10.592	11.099	11.478	10.954	10.070
North America (45.000)	30.526	29.767	31.340	31.396	30.927	31.352	31.531	33.523	33.782	36.083	36.084	39.243
Intra-Japan (30.000)	11.282	11.312	11.141	11.323	-	11.221	11.932	13.093	12.910	12.761	12.616	12.894
Trans Pacific (160.000)	101.320	99.414	99.400	99.399	134.714	99.336	99.320	99.238	99.237	99.242	99.240	99.250
Asia Pacific (125.000)	87.403	86.799	84.617	85.959	90.206	85.806	85.201	85.119	86.840	86.726	98.990	87.173
Latin America (140.000)	85.169	92.174	90.459	95.394	93.080	90.968	88.450	87.782	119.633	-	-	-
EMEA to Asia Pacific (250.000)	119.666	119.691	118.336	118.655	122.317	144.462	119.350	119.239	118.699	116.281	115.876	115.030

Ist HTTP besser ?

fforderung - powershell

```
Invoke-WebRequest https://outlook.offi
```

```
      : 200  
Description : OK  
      : {0, 0, 1, 0...}  
      : HTTP/1.1 200 OK  
      request-id: 894c265f-27fd-  
      X-CalculatedFETarget: BN6P  
      X-BackEndHttpStatus: 200,2  
      Accept-Ranges: bytes  
      Content-Length: 7886  
      Ca...  
      : {[request-id, 894c265f-27f  
      BN6PR03CU003.internal.outl  
length : 7886
```

Checking HTTP

- Office 365 hat einige nette URLs für Tests

- > Anonym erreichbar
- > Kein Throttling

Bereich	URL	Size
Exchange	https://outlook.office365.com/owa/healthcheck.htm	50 Bytes
Exchange	https://outlook.office365.com/owa/favicon.ico	7886 Bytes
Exchange	https://outlook.office365.com/owa/smime/owasmime.msi	729088 Bytes
OneDrive	https://<tenant>-my.sharepoint.com/	193 Bytes
SharePoint	https://<tenant>.sharepoint.com/	190 Bytes
SharePoint	https://<tenant>.sharepoint.com/_layouts/15/SPAndroidAppManifest.aspx	308 Bytes
EvoSTS	https://login.microsoftonline.com/common/oauth2/authorize	138361 Bytes

- Einfach per PowerShell Invoke-WebRequest abrufbar

- > Parameter -UseBasicParsing und -MaxRedirects 0
- > Processindicator abschalten! `$ProgressPreference="SilentlyContinue"`
- > Method HEAD statt GET beschränkt die Datenmenge



Basic HTTP-Request with PowerShell

```
(measure-command {  
    Invoke-WebRequest `  
        -URI https://outlook.office365.com/owa/favicon.ico  
}) .totalseconds
```

```
(measure-command {  
    Invoke-WebRequest `  
        -URI https://outlook.office365.com/owa/favicon.ico `  
        -UseBasicparsing  
}) .totalseconds
```

```
$ProgressPreference="SilentlyContinue"
```

```
(measure-command {  
    Invoke-WebRequest `  
        -URI https://outlook.office365.com/owa/smime/owasmime.msi  
}) .totalseconds
```

```
$ProgressPreference="Continue"
```

End2End-http: favicon.ico

Frankfurt Hotel 01:00am/07:00am

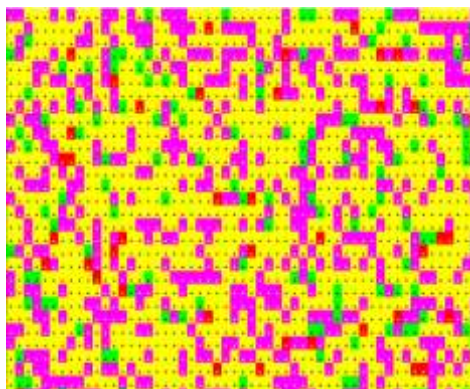
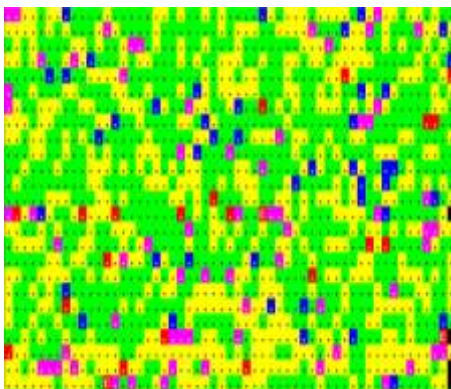

Vergleich zu ICMP

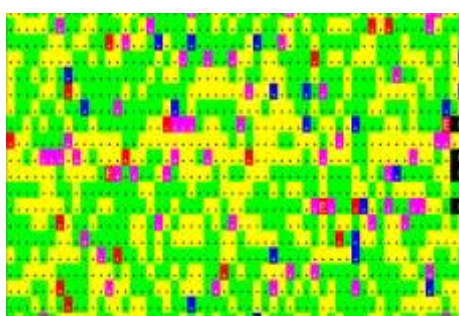
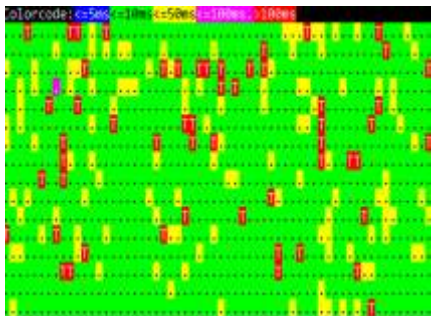

Bellevue Hotel 01:00am / 07:00p

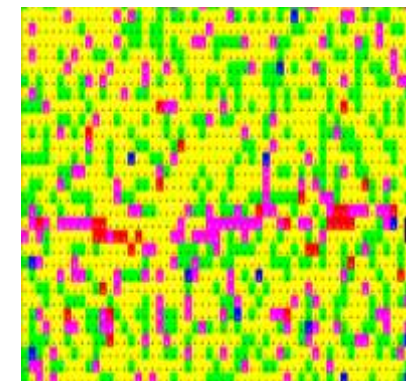
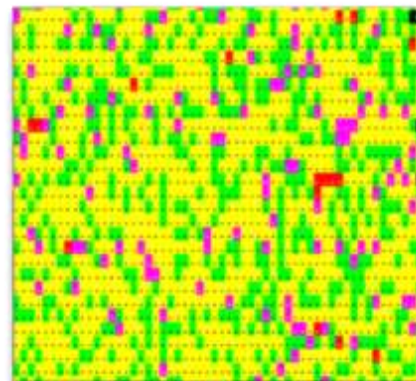

Vergleich zu ICMP

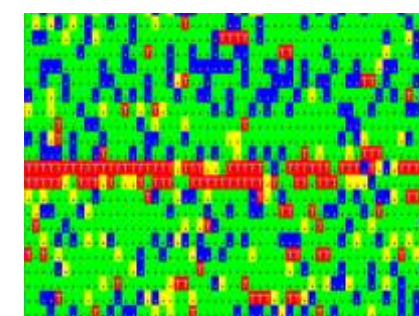
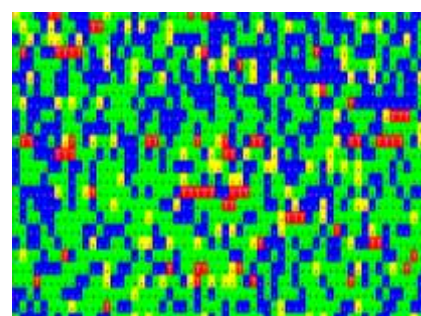

End2end-http mit 700k-Datei

- 700kByte in 105ms = ca. 66 Mbit !
- 700kByte in 5652 Sek = ca. 1,3 Mbit
 - › Packetloss? Paralleler PING?
- Farbcodierung von End2End-HTTP passt nicht
- Aber wollen Sie diese Dauerlast?

```
End2End-HTTP: URL = https://outlook.office365.com/owa/smime/owasmime.msi
Colorcode: <=20ms <=50ms <=100ms <=200ms >200ms
..... OK=27 Slow=9 Fail=0 MIN=153 AVG=692ms MAX=4251 X=End
..... OK=37 Slow=3 Fail=0 MIN=168 AVG=602ms MAX=5652 X=End
..... OK=42 Slow=2 Fail=0 MIN=156 AVG=354ms MAX=1388 X=End
..... OK=44 Slow=2 Fail=0 MIN=108 AVG=302ms MAX=1567 X=End
..... OK=48 Slow=1 Fail=0 MIN=123 AVG=222ms MAX=1012 X=End
..... OK=45 Slow=1 Fail=0 MIN=124 AVG=302ms MAX=1131 X=End
..... OK=42 Slow=2 Fail=0 MIN=105 AVG=346ms MAX=2217 X=End
..... OK=43 Slow=2 Fail=0 MIN=116 AVG=329ms MAX=1717 X=End
..... OK=46 Slow=0 Fail=0 MIN=131 AVG=278ms MAX=995 X=End
..... OK=35 Slow=5 Fail=1 MIN=150 AVG=405ms MAX=1053 X=End
```

Vergleich SNMP/HTTP

- Oben: SNMP
 - > Bytes in/out
 - > „Working hour“



- Unten: HTTP
 - > Response time
 - > „Jitter“
 - > Aber OK



Stresstest mit QoS

- Oben: SNMP
 - > Hohe WAN-Auslastung
 - > SNMP Abfrage
- Unten: HTTP
 - > HTTP-Favicon
 - > Latenz unkritisch!
- Warum?
 - > Bandwidth policy aktiviert für outlook.office365.com

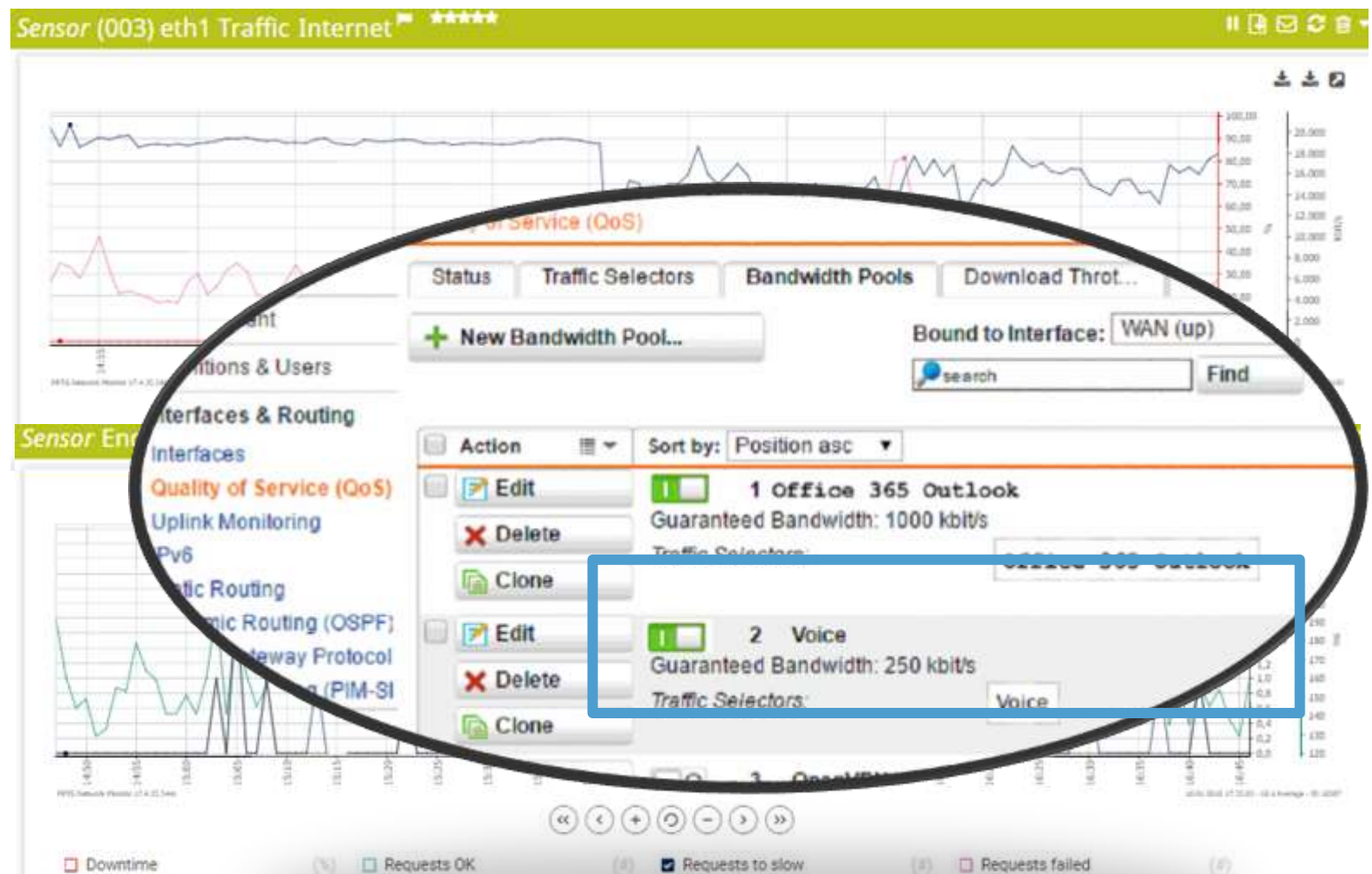

Sensor (003) eth1 Traffic Internet *****

Quality of Service (QoS)

Status Traffic Selectors Bandwidth Pools Download Throt...

+ New Bandwidth Pool...

Bound to Interface: WAN (up)

search Find

Sensor End

Interfaces & Routing

Interfaces

Quality of Service (QoS)

Uplink Monitoring

Pv6

Traffic Routing

Traffic Routing (OSPF)

Gateway Protocol

Routing (PIM-SI)

Action	Sort by:	Position asc
<input type="checkbox"/> Edit	<input checked="" type="checkbox"/>	1 Office 365 Outlook
<input type="checkbox"/> Delete		Guaranteed Bandwidth: 1000 kbit/s
<input type="checkbox"/> Clone		Traffic Selectors: outlook.office365.com
<input type="checkbox"/> Edit	<input checked="" type="checkbox"/>	2 Voice
<input type="checkbox"/> Delete		Guaranteed Bandwidth: 250 kbit/s
<input type="checkbox"/> Clone		Traffic Selectors: Voice

« < + ↻ - > »

Downtime Requests OK Requests to slow Requests failed

Exchange mit EWS



End2End-EWS Fiddler

Progress Telerik Fiddler Web Debugger

File Edit Rules Tools View Help Exchange Online (Disabled)

#	Overall_Ela...	Result	Prot...	Host	URL
1	0:00:00.262	200	HTTPS	www.fiddler2.com	/UpdateCheck.aspx?isBet...
3	0:00:01.098	200	HTTPS	dc.services.visualstudi...	/v2/track
5	0:00:00.766	404	HTTPS	netatwork.de	/autodiscover/autodiscov...
7	0:00:00.242	401	HTTPS	autodiscover.netatwor...	/autodiscover/autodiscov...
9	0:00:00.210	401	HTTPS	autodiscover.netatwor...	/autodiscover/autodiscov...
10	0:00:00.293	200	HTTPS	autodiscover.netatwor...	/autodiscover/autodiscov...
14	0:00:40.088	200	HTTPS	eastus2.notifications.t...	/users/8:orgid:0d63cd34-...
15	0:00:00.016	302	HTTP	autodiscover.netatwor...	/autodiscover/autodiscov...
17	0:00:00.010	401	HTTPS	autodiscover-s.outlook...	/autodiscover/autodiscov...
18	0:00:01.807	200	HTTPS	autodiscover-s.outlook...	/autodiscover/autodiscov...
20	0:00:00.023	401	HTTPS	outlook.office365.com	/EWS/Exchange.asmx
21	0:00:00.423	200	HTTPS	outlook.office365.com	/EWS/Exchange.asmx
22	0:00:00.091	401	HTTPS	outlook.office365.com	/EWS/Exchange.asmx
23	0:00:00.201	200	HTTPS	outlook.office365.com	/EWS/Exchange.asmx
24	0:00:00.009	401	HTTPS	outlook.office365.com	/EWS/Exchange.asmx
25	0:00:00.199	200	HTTPS	outlook.office365.com	/EWS/Exchange.asmx
26	0:00:00.061	401	HTTPS	outlook.office365.com	/EWS/Exchange.asmx
27	0:00:00.201	200	HTTPS	outlook.office365.com	/EWS/Exchange.asmx
29	0:00:00.094	401	HTTPS	outlook.office365.com	/EWS/Exchange.asmx
30	0:00:00.197	200	HTTPS	outlook.office365.com	/EWS/Exchange.asmx

Response Headers
HTTP/1.1 200 OK

Cache
Cache-Control: private
Date: Mon, 18 Mar 2019 12:22:08 GMT
Vary: Accept-Encoding

Cookies / Login
Set-Cookie: exchangecookie=ff2d2bfb560141d3a294a087ecc2b87e; path=/

Entity
Content-Length: 3547
Content-Type: text/xml; charset=utf-8

Miscellaneous
request-id: ab475c60-41d4-44d5-bd68-38c8804ba5e0
Server: Microsoft-IIS/10.0
X-AspNet-Version: 4.0.30319
X-BackendHttpStatus: 200
X-BackendHttpStatus: 200
X-BEServer: AM6PR04MB5013
X-BeSku: WCS5
X-CalculatedBETarget: AM6PR04MB5013.eurprd04.prod.outlook.com
X-CalculatedFETarget: AM6PR0402CU001.internal.outlook.com
X-DiagInfo: AM6PR04MB5013
x-EwsHandler: FindItem
~~X-FEProxyInfo: AM6PR0402CA0034.EURPRD04.PROD.OUTLOOK.COM~~
X-FEServer: AM6PR0402CA0034
X-FEServer: MWHPR2201CA0074
X-Powered-By: ASP.NET
X-RUM-Validated: 1



EWS Details

- Informationen über
 - > Edge Frontend
 - > Mittleren Frontend
 - > Backend
- Frontend: Affinity
- Middle: RoundRobin
- Backend: Static
- SwitchOver Detection

```
Windows PowerShell
PS C:\group\Technik\Skripte\end2end\end2end-ews> .\end2end-ews.20190115
End2End-EWS: Start
Loading EWS DLL
Username:
Domain :
Password: <not visible>
UseDefaultCredentials: False
End2End-EWS:Checking Autodiscover for Mailbox
End2End-EWS:ServiceURL: Using Autodiscover for frank.carius@netatwork.de
End2End-EWS:Use ServiceURI: https://outlook.office365.com/EWS/Exchange.asmx
End2End-EWS:Connecting to Inbox for SMTP frank.carius@netatwork.de
Number of Unread Messages : 7273
End2End-EWS: Start Monitoring Loop
End2End-EWS (1): FE1:MWHPR14CA0026 FE2:AM6P191CA0064 BE:AM6PR04MB5013 RTT(ms)994
Key detected
End2End-EWS (2): FE1:MWHPR14CA0026 FE2:AM6P192CA0071 BE:AM6PR04MB5013 RTT(ms)217
End2End-EWS (3): FE1:MWHPR14CA0026 FE2:AM6P193CA0021 BE:AM6PR04MB5013 RTT(ms)1034
End2End-EWS (4): FE1:MWHPR14CA0026 FE2:AM6P191CA0036 BE:AM6PR04MB5013 RTT(ms)201
End2End-EWS (5): FE1:MWHPR14CA0026 FE2:AM6P192CA0071 BE:AM6PR04MB5013 RTT(ms)186
End2End-EWS (6): FE1:MWHPR14CA0026 FE2:AM6P191CA0036 BE:AM6PR04MB5013 RTT(ms)238
End2End-EWS (7): FE1:MWHPR14CA0026 FE2:AM6P191CA0064 BE:AM6PR04MB5013 RTT(ms)240
End2End-EWS (8): FE1:MWHPR14CA0026 FE2:AM6P191CA0036 BE:AM6PR04MB5013 RTT(ms)255
End2End-EWS (9): FE1:MWHPR14CA0026 FE2:AM6P191CA0064 BE:AM6PR04MB5013 RTT(ms)238
End2End-EWS (10): FE1:MWHPR14CA0026 FE2:AM6P193CA0021 BE:AM6PR04MB5013 RTT(ms)239
End2End-EWS (11): FE1:MWHPR14CA0026 FE2:AM6P191CA0064 BE:AM6PR04MB5013 RTT(ms)239
End2End-EWS (12): FE1:MWHPR14CA0026 FE2:AM6P193CA0021 BE:AM6PR04MB5013 RTT(ms)239
End2End-EWS (13): FE1:MWHPR14CA0026 FE2:AM6P191CA0064 BE:AM6PR04MB5013 RTT(ms)244
End2End-EWS (14): FE1:MWHPR14CA0026 FE2:AM6P193CA0021 BE:AM6PR04MB5013 RTT(ms)249
End2End-EWS (15): FE1:MWHPR14CA0026 FE2:AM6P191CA0064 BE:AM6PR04MB5013 RTT(ms)232
End2End-EWS (16): FE1:MWHPR14CA0026 FE2:AM6P193CA0021 BE:AM6PR04MB5013 RTT(ms)253
```



Standortcode über Zeiten

- Ein Client mit End2End-HTTP
- Verschiedene Frontend Sites
- Frankfurt/Berlin geht online
3. Dez 2019 – 6. Dez 2019

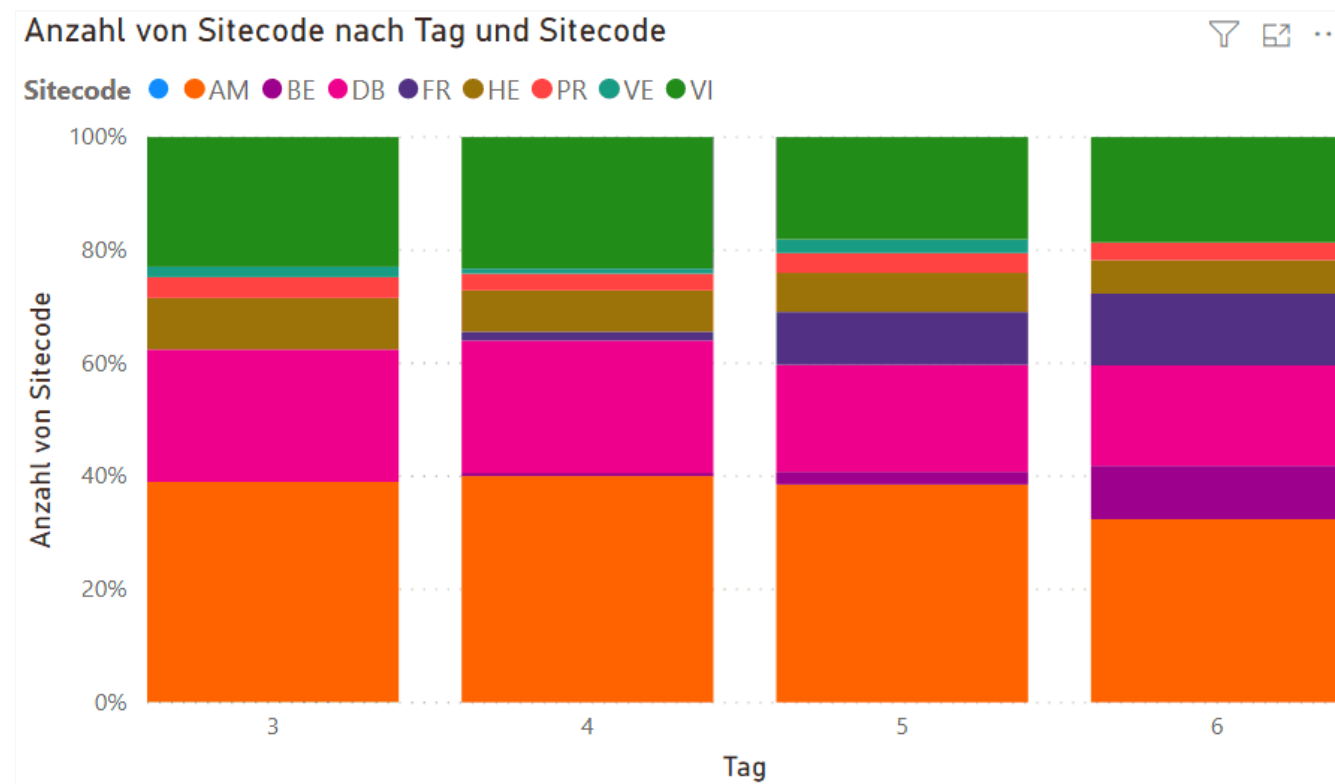

SharePoint





SharePoint Online

- Protokoll: HTTPS
- URL
 - > <tenantname>.sharepoint.com
 - > <tenantname>-my.sharepoint.com
- End2EndHTTP
 - > Messung nur bis FrontEnd-Server
 - > Aber „interne Verarbeitung“ sichtbar
- <https://www.msxfaq.de/tools/end2end/end2end-sharepoint.htm>
- (Invoke-WebRequest https://<tenant>.sharepoint.com/_layouts/15/SPAndroidAppManifest.aspx).headers

```

GET https://msxfaq.sharepoint.com/_layouts/15/SPAndroidAppManifest.aspx HTTP/1.1
User-Agent: Mozilla/5.0 (Windows NT; Windows NT 10.0; de-DE)
WindowsPowerShell/5.1.18362.145
Host: msxfaq.sharepoint.com

Response Headers
HTTP/1.1 200 OK

Cache
Cookies / Login
Entity
Miscellaneous
  MicrosoftSharePointTeamServices: 16.0.0.19520
  MS-CV: nyKrwC5AAJC/RLp6XAYIcA.0
  request.id: c0ab229f-402e-9000-bf44-ba7a5c062570
  SPisLatency: 1
  SPRRequestDuration: 112
  SPRRequestGuid: c0ab229f-402e-9000-bf44-ba7a5c062570
  X-AspNet-Version: 4.0.30319
  X-MS-Edge-Ref: Ref A: 187B1EDD2CCC4878B08FB6A7ED922BD5 Ref B: AM3EDGE0412 Ref C: 2019-12-18T10:30:32Z
  X-MS-InvokeApp: 1; RequireReadOnly
  X-Powered-By: ASP.NET
  X-SharePointHealthScore: 7
  
```

Anzahl von Sphealthscore nach Sphealthscore



Latenz mit TURN



RTP Measurement with SfB Assessment Tool

- Start a synthetic call to „13.107.8.2“ (global.tr.skype.com)
 - › And other Services (Port 3479)
 - › One single call
 - › Duration 17 sec
 - › Sleeptime 5 sec

```

D:\nawcd\Microsoft\Lync\AddOns\Skype for Business Online Network Asse
Skype for Business - Network Assessment Tool
Initializing audio call.
Remote IP address: 13.107.8.20
Audio file used: Tone.wma
Audio call duration: 17 s
Received audio file: ReceivedAudioFile.wma
Num iterations: 1
Call interval: 5 s
Results File: results.tsv
*****
Starting new call
Iteration 1 / 1
  
```

Wireshark · Conversations · wireshark_C566EF7E-D476-40C7-8078-C0E35BE4EBB0_20180304063304_a18280

Ethernet · 30		IPv4 · 60		IPv6 · 7	TCP · 56	UDP · 57							
Address A	Port A	Address B	Port B	Packets	Bytes	Packets	Bytes	Packets B → A	Bytes B → A	Rel Start	Duration	Bits/s A → B	Bits/s B → A
192.168.6.135	50014	13.107.8.2	3478	2	339	1	146	1	193	2.509222	0.0071	165 k	218 k
192.168.6.135	50014	52.114.188.31	3479	860	478 k	430	239 k	430	238 k	2.663538	17.7723	107 k	107 k
192.168.6.135	5353	224.0.0.251	5353	2	318	2	318	0	0	37.405558	0.8362	38 k	38 k



Sample: End2End-UDP3478

- Home DSL
 - > 13 Hops Abstand
 - > 20-50ms RTT
 - > Paketverlust
- MSFTGuest
 - > 15 Hops Abstand
 - > 13ms AVG RTT

```

Auswählen End2End-UDP3478
PS C:\End2End> .\end2end-udp3478.ps1
End2End-UDP3467:Start
Mode           : END2END. continuous latency check and no distance check
MaxTTL         : 128
MaxRetries     : 0
AvgIntervalSec : 60
InterpacketsleepMS : 20
Sleeptime      : 0
prtgpushurl    :
TURN-Server    : Use Office 365 Microsoft Teams Server: IP=52.113.193.5
End2End-UDP3478:Start UDP-Client on 50019
End2End-UDP3478:Connect UDPClient to 52.113.193.5:3478
Colorcode: <=100ms<=200ms>200ms
Legend: 100 pakets max: . = max<100ms W= max<200ms E=max>200ms
End2End-UDP3478:Keyboard: use X=End P=Pause
2020-10-14 00:10:16Z:RTT: ..... (Min/Avg/Max):013/016/039 Total/Fail:1218/000
2020-10-14 00:11:16Z:RTT: ..... (Min/Avg/Max):014/016/028 Total/Fail:1215/000
2020-10-14 00:12:16Z:RTT: ..... (Min/Avg/Max):013/016/048 Total/Fail:1169/000
2020-10-14 00:13:16Z:RTT: ..... (Min/Avg/Max):014/016/055 Total/Fail:1183/000
2020-10-14 00:14:16Z:RTT: ..... (Min/Avg/Max):014/016/041 Total/Fail:1184/000
2020-10-14 00:15:16Z:RTT: ..... (Min/Avg/Max):014/016/020 Total/Fail:1203/000
2020-10-14 00:16:16Z:RTT: ..... E (Min/Avg/Max):013/016/037 Total/Fail:1186/001
2020-10-14 00:17:16Z:RTT: ..... (Min/Avg/Max):013/016/049 Total/Fail:1182/000
2020-10-14 00:18:16Z:RTT: ..... (Min/Avg/Max):014/016/020 Total/Fail:1211/000
2020-10-14 00:19:16Z:RTT: ..... (Min/Avg/Max):013/016/019 Total/Fail:1188/000
2020-10-14 00:20:17Z:RTT: ..... (Min/Avg/Max):013/016/019 Total/Fail:1205/000
2020-10-14 00:21:17Z:RTT: ..... (Min/Avg/Max):014/016/019 Total/Fail:1202/000
2020-10-14 00:22:17Z:RTT: ..... (Min/Avg/Max):013/016/033 Total/Fail:1196/000
2020-10-14 00:23:17Z:RTT: ..... (Min/Avg/Max):014/016/020 Total/Fail:1192/000
2020-10-14 00:24:17Z:RTT: ..... (Min/Avg/Max):014/016/019 Total/Fail:1189/000
2020-10-14 00:25:17Z:RTT: ..... (Min/Avg/Max):013/016/023 Total/Fail:1179/000
2020-10-14 00:26:17Z:RTT: ..... (Min/Avg/Max):014/016/026 Total/Fail:1169/000
2020-10-14 00:27:17Z:RTT: ..... (Min/Avg/Max):013/016/028 Total/Fail:1206/000
2020-10-14 00:28:17Z:RTT: ..... E ..... (Min/Avg/Max):013/017/047 Total/Fail:1179/001
2020-10-14 00:29:17Z:RTT: ..... E ..... (Min/Avg/Max):014/017/054 Total/Fail:1162/001
2020-10-14 00:30:17Z:RTT: ..... (Min/Avg/Max):013/017/045 Total/Fail:1179/000
2020-10-14 00:31:17Z:RTT: ..... (Min/Avg/Max):014/017/049 Total/Fail:1181/000
2020-10-14 00:32:17Z:RTT: ..... E ..... (Min/Avg/Max):013/017/053 Total/Fail:1171/001
2020-10-14 00:33:17Z:RTT: ..... E ..... (Min/Avg/Max):014/016/045 Total/Fail:1181/001
2020-10-14 00:34:17Z:RTT: ..... (Min/Avg/Max):014/017/050 Total/Fail:1175/000
2020-10-14 00:35:17Z:RTT: ..... (Min/Avg/Max):013/016/039 Total/Fail:1180/000
2020-10-14 00:36:17Z:RTT: ..... (Min/Avg/Max):013/018/058 Total/Fail:1137/000

```

Beispiel: End2End-UDP3478

- PowerShell
 - > 50 UDP-Pakete pro Sekunde
 - > 160 Bytes = 1 VoIP Call
 - > Gegenstelle: TURN-Server
 - > Misst RTT und Hopcount
- Entfernung (grau)
 - > 10 Hops Baseline
 - > 03:00pm-11am
 - > RTT higher
- RTT Min/Avg/Max
 - > Still <100ms

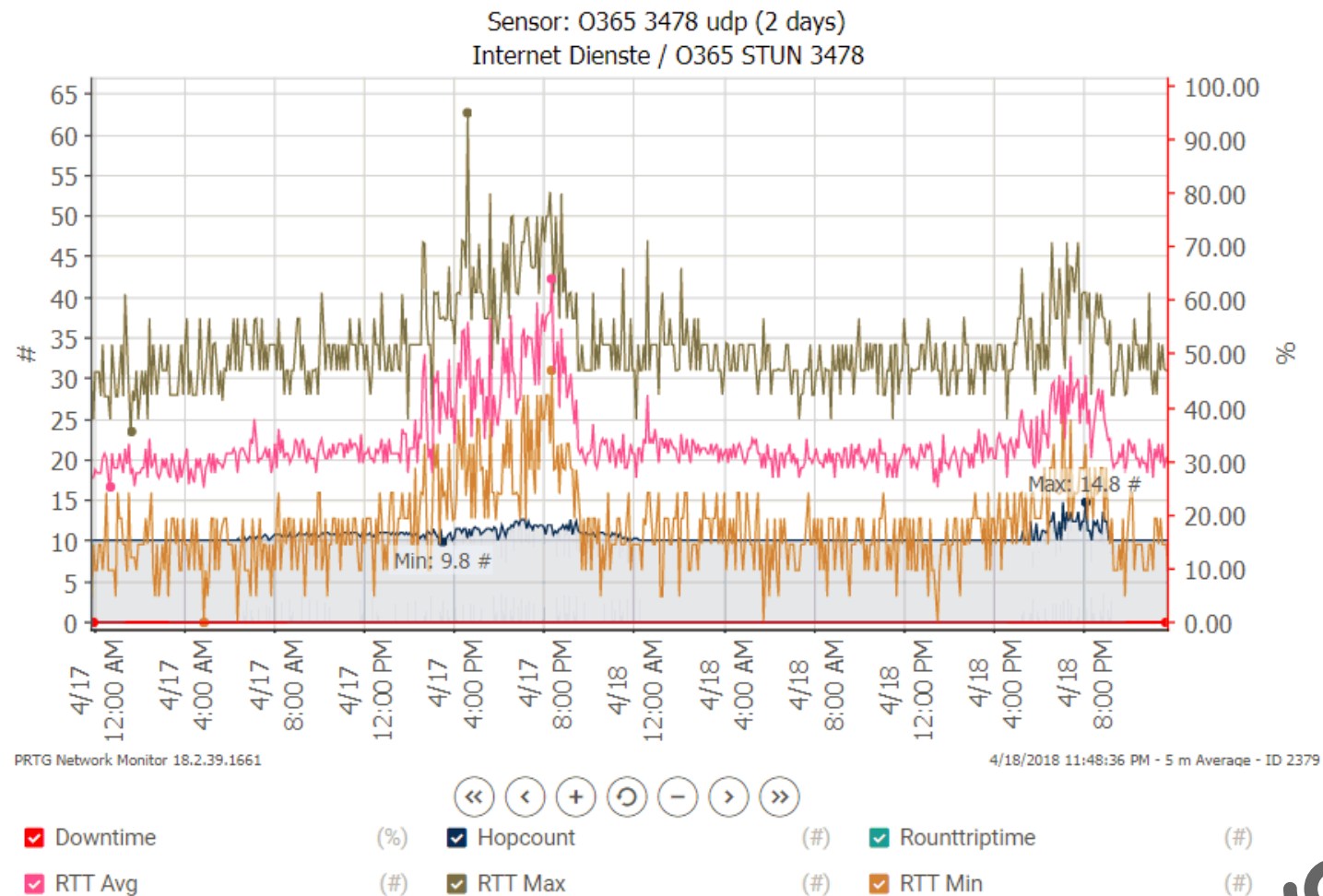

Missing: Connection advisor on every client

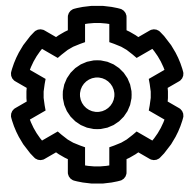

Configuration

- LAN/WLAN, Network boards, Default Gateway, Routing
- DNS-Server, Proxy-Server
- Operating System, Patchlevel, „Teams-Version“, ...

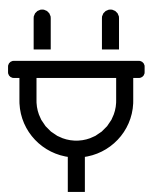

Connectivity

- Are all Services „reachable“ ? (ICMP, DNS, UDP, TCP, HTTP)
- Especially Microsoft 365 services (Exchange, SharePoint, Teams, ...)
- Other Cloud Services (Yes, they are also in use)
- Own services like VPN-Servers, Terminal Services gateways, ...



Durability

- Bandbreite vs. Latenzzeit, Packetloss, Jitter, Throughput
- Whats visible for the end user
- How reliable is that connection



Rimscout: Sample Reports

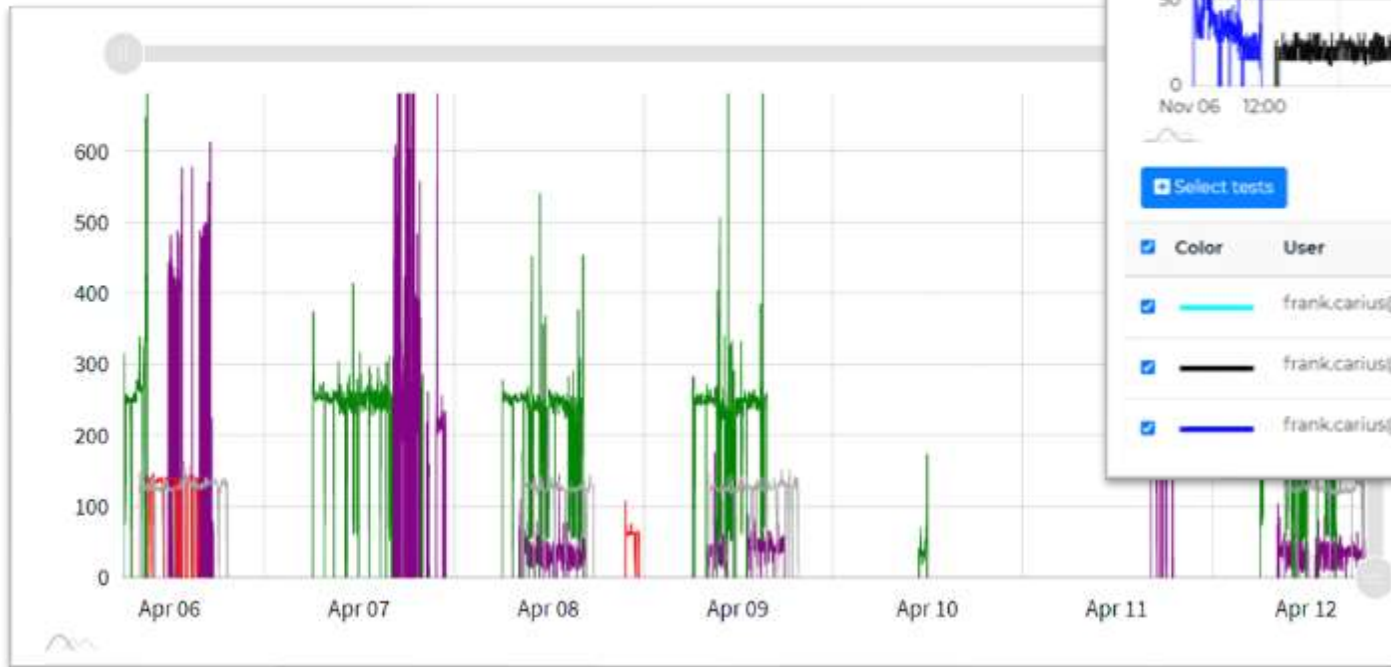

Kurzfassung Checkliste

- ❑ **Optimierte Leitwege zum Internet für Office 365**
 - ❑ Local Breakout, HTTP-Proxy-Bypass, Keine Deep-Inspection
- ❑ **Client-VPN**
 - ❑ Split-VPN und Split-DNS statt Tunnel. Sonderfall IPv6-Tunnel
- ❑ **Korrekte DNS-Namensauflösung**
 - ❑ DNS follows IP-Routing, Kein „Google“-DNS, kein Cloud-Filter-DNS
- ❑ **UDP 3478-3481 für optimierte Teams/Skype A/V-Übertragung**
 - ❑ Auch für WebEx, Zoom und Co? Fritz!Box-GästeWLAN blockt UDP
- ❑ **CRL Access für Zertifikatsprüfungen**
- ❑ **TCP-Feinheiten kontrollieren**
 - ❑ TCP-Connections, NAT-Limit, Session-Timeout, Keepalive
 - ❑ MTU/TCP Segment size, QoS-Tagging, Teams Portrange
 - ❑ Windows Scaling (MSS), RSS, Offloading, SACK
- ❑ **Monitoring: Round Trip Time messen und einhalten**

Microsoft 365 network connectivity principles

<https://docs.microsoft.com/de-de/microsoft-365/enterprise/microsoft-365-network-connectivity-principles?view=o365-worldwide>

Prepare your organization's network for Microsoft Teams

<https://docs.microsoft.com/de-de/microsoftteams/prepare-network>



