



**1. GET
THE APP**



**2. VISIT SESSIONS
AND SPONSORS,
RATE THE SESSIONS**



**3. EARN
COLLABCOINS**



**4. SPEND COLLABCOINS
ON SWAG AND
VOUCHERS**

**5. TOP 5 WIN A
RASPBERRY PI 400**



csmmt.eu/app



HOW TO BUILD A PROPER CONNECTION TO CLOUD SERVICES

Frank Carius

MVP, MCM Lync

Net at Work GmbH

Frank.carius@netatwork.de



29TH NOVEMBER – 1ST DECEMBER 2021



DIAMOND AND PLATINUM SPONSORS



My company and me



Frank Carius

Consultant and partner
MVP (20+ years)
MCM Lync 2010
<https://www.msxfaq.de>

My mission for today

- Lessons learned from many past “network assessment”
- Give you a “fresh up” about well known topics
- Show you additional options to monitor your network

Net at Work

130+ Employees

Founded: 1995

Head Office: Paderborn

System integrator with solutions and tools for
your digital communication and collaboration



Think about trucks ...

- You are a gatekeeper at a factory exit and...
 - ... you count the truck in/out
 - ... you weight the trucks

Thats SNMP-Monitoring today!

- SNMP means
 - Measures packets/sec In/Out
 - Measures bytes/sec In/Out
 - Shows bandwidth utilization
- Is this valid to measure cloud performance?
 - Low utilization = no problem ?
 - Far network congestion = empty gate
 - Providers are not delivering „Live traffic maps“
- We have to change our current monitoring?





Challenges – Network Evolution

- Prior cloud adoption
 - Structured progress, data collection and forecast (hopefully)
 - How much bandwidth do we need?
 - Do we really have to buy more bandwidth? (\$\$\$)
 - Can we have some estimations, can we measure our current system ?
 - Can we make sure that ... everything is working. Can you certify that?
- Spring 2020 (Covid, Homeoffice, inbound, offload)
 - bandwidth overload, SfB OnPremises, high load on VPN-Servers, ...
 - Quick Migration to Cloud Services (primarily Teams, Zoom, ...)
 - Companies have increased bandwidth and VPN-Servers
- 2021 Back to office – outgoing traffic
 - People were coming back to the office
 - But they will not stop using teams and other cloud service





- What Microsoft tells us (Slide 1-3)

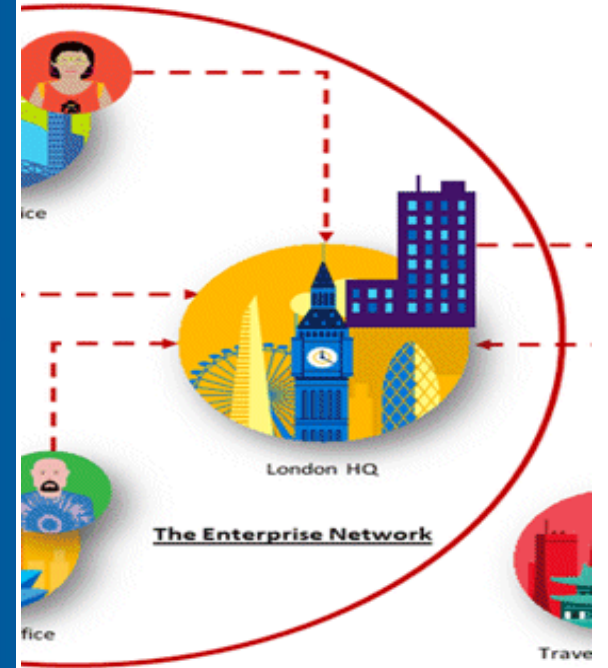



Office 365 Guiding Principles

Identify and differentiate Office 365 traffic using Microsoft published endpoints

Egress Office 365 data connections as close to the user as practical with matching DNS resolution

Avoid network hairpins and optimize connectivity directly into the nearest entry point into Microsoft's global network

Assess bypassing proxies, traffic inspection devices and duplicate security which is available in Office 365

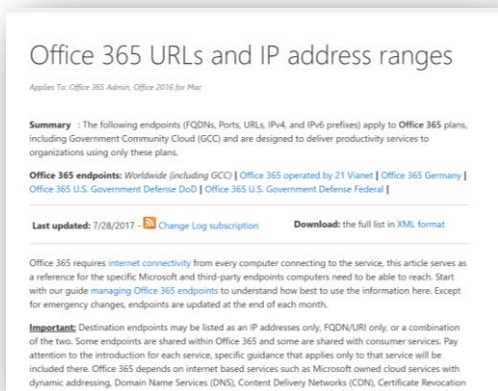

aka.ms/o365ip

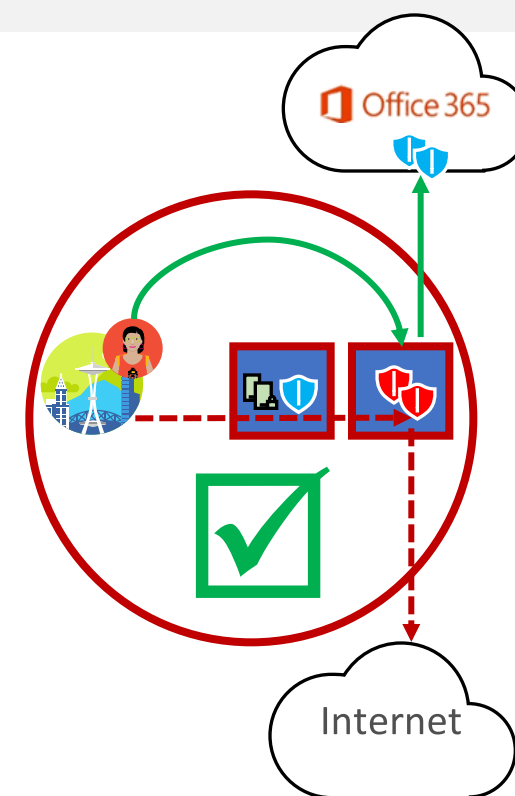
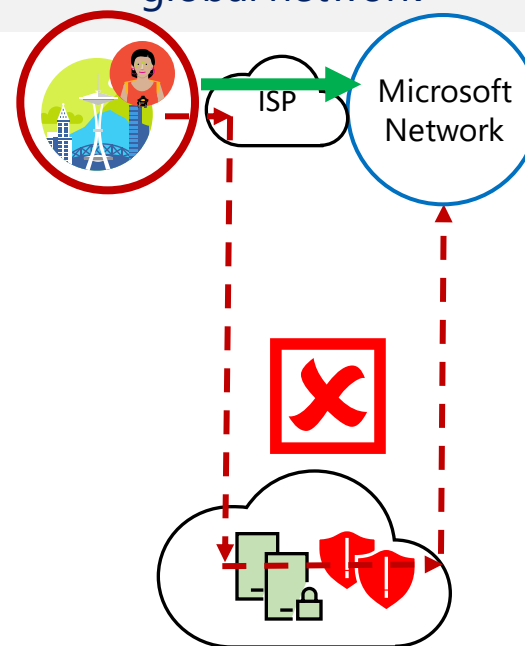
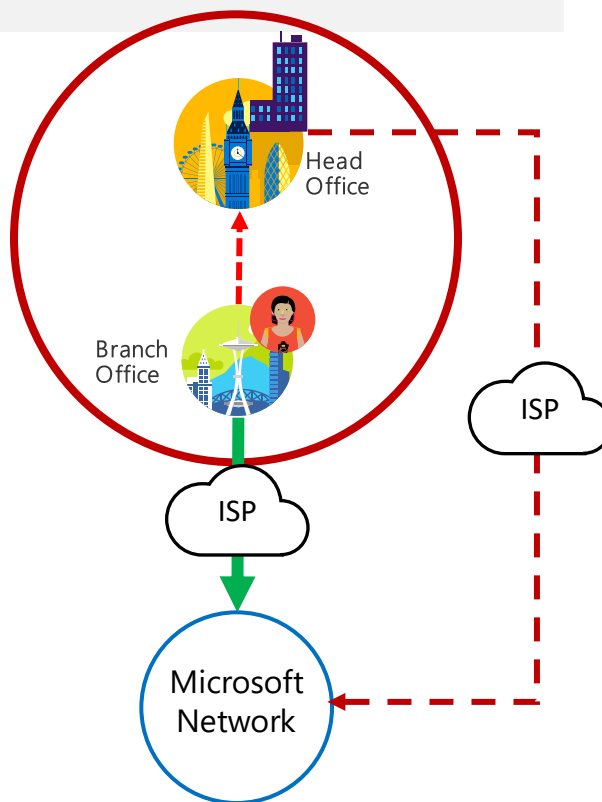



Target: Optimize, Allow and Default

Office 365 endpoints (FQDNs, IPs, ports, protocols)

- Office 365 REST API (<http://aka.ms/ipurlws>) for automating customer Office 365 network settings
- Priority driven endpoint taxonomy (<http://aka.ms/ipurlblog>) for easier customer network optimizations
- Growing support for native integration across partner community
- **Key point: Focus your network optimization on key Office 365 experiences first (Optimize set)**

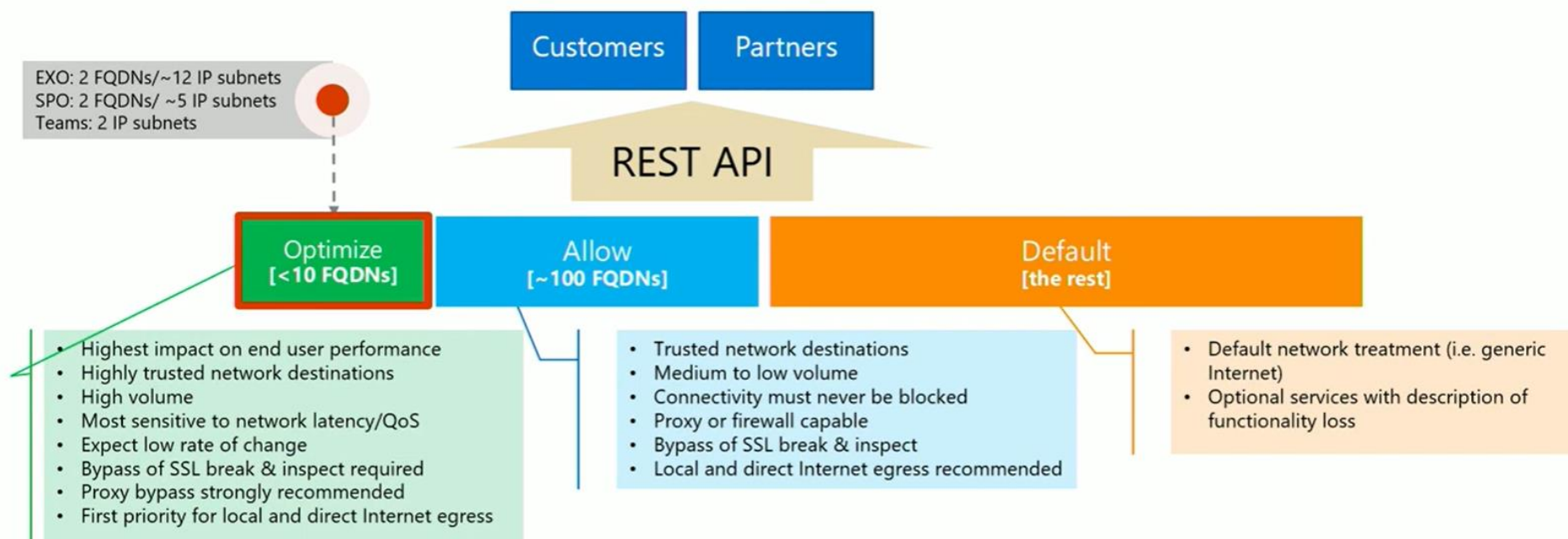

Optimal network connectivity for Office 365 performance: What is it and how to get | BRK3040

Source: <https://youtu.be/XiQwR12rkO8?t=1564>



More Microsoft Links

- Office 365 Connectivity Principles in greater detail
<https://aka.ms/PNC>
<https://techcommunity.microsoft.com/t5/Office-365-Blog/Getting-the-best-connectivity-and-performance-in-Office-365/ba-p/124694>
- Office 365 product group videos expanding on the Office 365 connectivity principles:
Strategy: <https://youtu.be/19a8s90HboQ>
Planning: <https://youtu.be/cJDpB59gk3M>
Implementation: <https://youtu.be/lZwvitkvg6A>
- Optimal network connectivity for Office 365 performance: What is it and how to get | BRK3040
<https://aka.ms/brk3000> ->
<https://www.youtube.com/watch?v=XiQwR12rkO8>
- Guidance on network planning and perf tuning in Office 365
<https://aka.ms/tune>
- Office 365 URLs and IP addresses:
<https://aka.ms/O365IP>
- Managing bandwidth requirements for Office 365
<https://aka.ms/O365networkconnectivity>
- Getting the best connectivity and performance in Office 365
<https://techcommunity.microsoft.com/t5/office-365-blog/getting-the-best-connectivity-and-performance-in-office-365/ba-p/124694>
- Announcing: Office 365 endpoint categories and Office 365 IP Address and URL web service
<https://techcommunity.microsoft.com/t5/office-365-blog/announcing-office-365-endpoint-categories-and-office-365-ip/ba-p/177638>
- Understanding optimizing&securing enterprise network
<https://techcommunity.microsoft.com/t5/Microsoft-Tech-Summit-Content-17/Understanding-optimizing-amp-securing-enterprise-network/td-p/126371>

- Microsoft Global Network





Microsoft Global Network

- Microsofts own world wide network
 - 200+ Peering Locations, 4000+ Network, 100+ Frontdoor-Locations, 50 Datacenter Regions
 - Owned fiber (>800.000km in USA) (document from 2015)
[http://download.microsoft.com/download/8/2/9/8297F7C7-AE81-4E99-B1DB-D65A01F7A8EF/Microsoft Cloud Infrastructure Datacenter and Network Fact Sheet.pdf](http://download.microsoft.com/download/8/2/9/8297F7C7-AE81-4E99-B1DB-D65A01F7A8EF/Microsoft%20Cloud%20Infrastructure%20Datacenter%20and%20Network%20Fact%20Sheet.pdf)
 - QoS managed, no loss, no jitter
 - Multiple Terabit Peerings
 - See BRK3000 - Strategies for building effective, optimal and future proof connectivity to Office 365 that will delight your users
- BGP: Microsoft ASN= 8075
 - <https://www.peeringdb.com/asn/8075>
 - <https://stat.ripe.net/AS8075#tabId=at-a-glance>
 - #IPv4 Prefix:149 about 20.184.320 IPs
 - #IPv6 Prefix:10 about 8.589.324 /48s
- Peering List for Azure
 - <https://docs.microsoft.com/en-us/rest/api/peering/peeringlocations/list>

Azure inter-DC dark fiber backbone

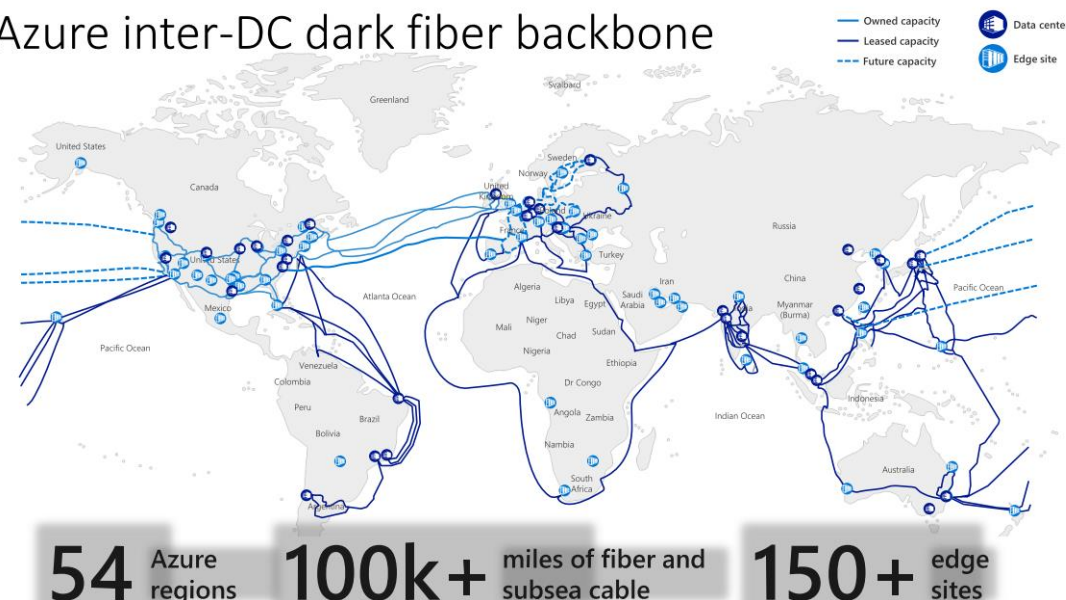



Connect your client to the service

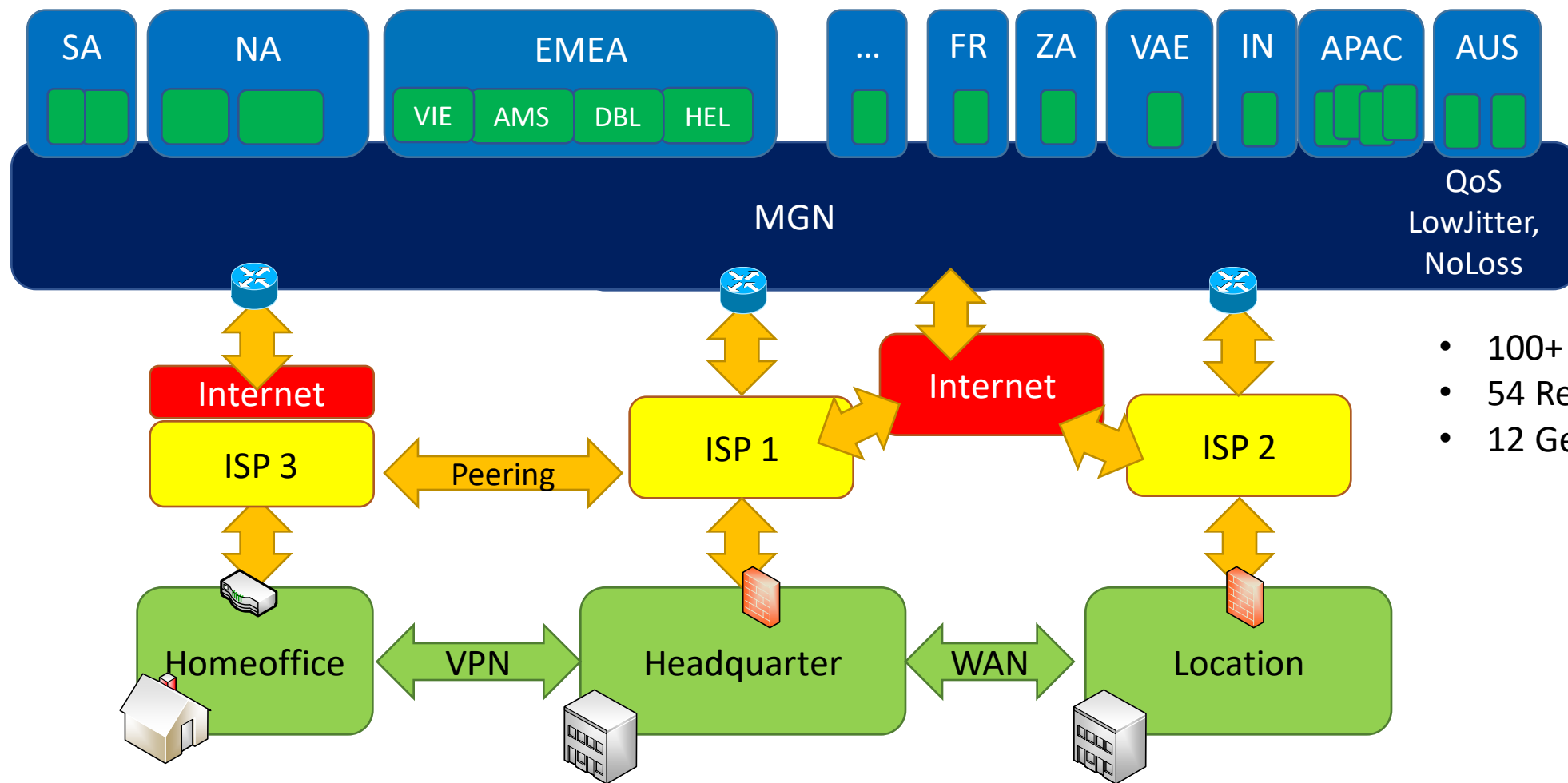

- 100+ Azure RZs
- 54 Regions
- 12 Geos





M365 is not „the internet“. Hot potato

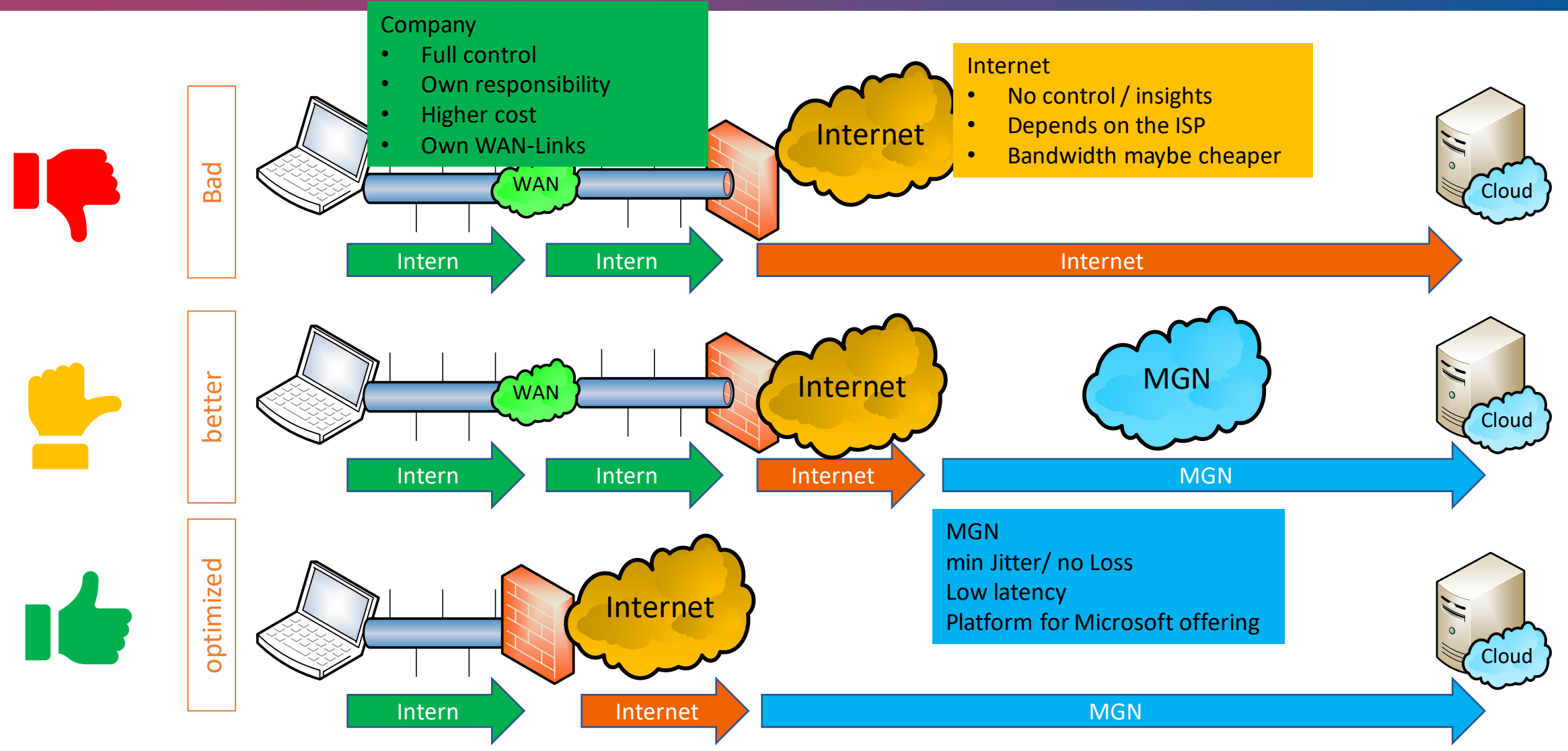

Peerings



- Public Peering
 - AMS-IX, DECIX, u.a.
 - Check your routing, ask your upstream provider, do a traceroute
 - <https://peeringdb.com>
- Expressroute
 - Bring your own Eigene Leitung zu Azure
 - BGP-Routing
 - POP in Amsterdam und Rotterdam
- Option: Provider with Peerings (Auszug)
 - Peering Service Preview Partners
<https://docs.microsoft.com/en-us/azure/peering-service/location-partners>
 - DeCIX Azure Peering Services
<https://www.de-cix.net/en/de-cix-service-world/closed-user-groups/microsoft-azure-peering-service>
 - Colt
<https://www.colt.net/why-colt/strategic-alliances/microsoft-partnership/>
 - InterCloud
<https://intercloud.com/partners/microsoft-saas-applications/>
 - interxion
<https://www.interxion.com/why-interxion/colocate-with-the-clouds/Microsoft-Azure/>



Microsoft Peering

The screenshot shows the Microsoft Peering website interface. At the top, there is a navigation bar with the Microsoft logo and a 'Peering' link. Below this, a 'Peering' section is visible. A callout box highlights a list of services provided by Microsoft, including a fully redundant network, a 24x7x365 NOC, and assistance with technical and security issues. Another callout box titled 'Additional Requirements for Private Interconnections' lists specific technical requirements, such as the use of single-mode fiber with 10Gbps or 100Gbps optics and the requirement to upgrade ports when peak utilization exceeds 50%.

- A fully redundant network with sufficient capacity to exchange traffic without congestion.
- A knowledgeable and fully staffed 24x7x365 Network Operations Center (NOC), capable of assisting in the resolution of:
 - All technical and performance issues.
 - All security violations, denial of service attacks, or any other abuse originating within the peer or their customers.
- Microsoft will overv
 - Acceptance
- A publicly routable
- At least one publicl
- Current and comple
- account and phone
- Neither party chall

Additional Requirements for Private Interconnections

- Interconnection must be over single-mode fiber using the appropriate 10Gbps or 100Gbps optics.
- Peers are expected to upgrade their ports when peak utilization exceeds 50% and maintain diverse capacity in each metro, either within a single location or across several locations in a metro.
- Microsoft will only establish private interconnection points with ISP or Network Service providers.

Microsoft Peering Policy

<https://www.microsoft.com/peering> -> <https://peering.azurewebsites.net/peering/>





```
C:\> Eingabeaufforderung - pwsh
PS C:\Users\fcarius> tracert outlook.office365.com

Routenverfolgung zu FRA-efz.ms-acdc.office.com [52.97.223.82]
über maximal 30 Hops:

  1    1 ms    2 ms    1 ms  10.42.0.1
  2    1 ms    1 ms    1 ms  port-195-158-157-129.static.isionline-dialin.de [195.158.157.129]
  3    2 ms    1 ms   15 ms  ipservice-092-214-080-105.092.214.pools.vodafone-ip.de [92.214.80.105]
  4    3 ms    2 ms    2 ms  88.79.20.28
  5    4 ms    4 ms    3 ms  188.111.129.22
  6    3 ms    3 ms    3 ms  145.254.2.183
  7    4 ms    3 ms    4 ms  ae60-0.ier01.dus30.ntwk.msn.net [104.44.36.177]
  8   14 ms   21 ms    7 ms  ae27-0.icr01.ams30.ntwk.msn.net [104.44.42.95]
  9    9 ms    9 ms    9 ms  be-100-0.ibr01.ams30.ntwk.msn.net [104.44.22.215]
 10    9 ms    8 ms    9 ms  be-9-0.ibr03.ams06.ntwk.msn.net [104.44.29.249]
 11   13 ms    8 ms    8 ms  ae142-0.icr02.ams06.ntwk.msn.net [104.44.21.174]
 12    *      *      *      Zeitüberschreitung der Anforderung.
 13    *      *      *      Zeitüberschreitung der Anforderung.
 14    *      *      *      Zeitüberschreitung der Anforderung.
 15    *      *      *      Zeitüberschreitung der Anforderung.
 16    *      *      *      Zeitüberschreitung der Anforderung.
 17    8 ms    8 ms    7 ms  52.97.223.82

Ablaufverfolgung beendet.
```

TRACEROUTE, PEERINGDB

- The magic of DNS





DEMO: DNS WITH EXCHANGE ONLINE



DNS Round Robin / TTL

- outlook.office365.com is CNAME to outlook.ms-acdc.office.com
- outlook.ms-acdc.officerc.com is CNAME to <region>.ms-acdc.office.com
- <region>.ms-acdc.office.com has multiple A-Records
- All entries have a very short TTL!

```
PowerShell 7 (x64)
PS C:\> Get-DnsClientCache outlook.office365.com | ft -AutoSize
```

Entry	RecordName	RecordType	Status	Section	TimeToLive	Data
outlook.office365.com	outlook.office365.com	CNAME	Success	Answer	2	outlook.ms-acdc.office.com
outlook.office365.com	outlook.ms-acdc.office.com	CNAME	Success	Answer	2	FRA-efz.ms-acdc.office.com
outlook.office365.com	FRA-efz.ms-acdc.office.com	AAAA	Success	Answer	2	2603:1026:200:63::2
outlook.office365.com	FRA-efz.ms-acdc.office.com	AAAA	Success	Answer	2	2603:1026:207:131::2
outlook.office365.com	FRA-efz.ms-acdc.office.com	AAAA	Success	Answer	2	2603:1026:207:cd::2
outlook.office365.com	outlook.office365.com	CNAME	Success	Answer	8	outlook.ms-acdc.office.com
outlook.office365.com	outlook.ms-acdc.office.com	CNAME	Success	Answer	8	FRA-efz.ms-acdc.office.com
outlook.office365.com	FRA-efz.ms-acdc.office.com	A	Success	Answer	8	40.101.19.162
outlook.office365.com	FRA-efz.ms-acdc.office.com	A	Success	Answer	8	40.101.121.34
outlook.office365.com	FRA-efz.ms-acdc.office.com	A	Success	Answer	8	40.101.80.2

Sample: wrong DNS-Server



```
C:\>nslookup outlook.office
Server: home1.bellatlantic
Address: 199.45.32.43
```

```
Nicht autorisierende Antwort
Name: MNZ-efz.ms-acdc.office
Addresses: 2603:1036:302:4
```

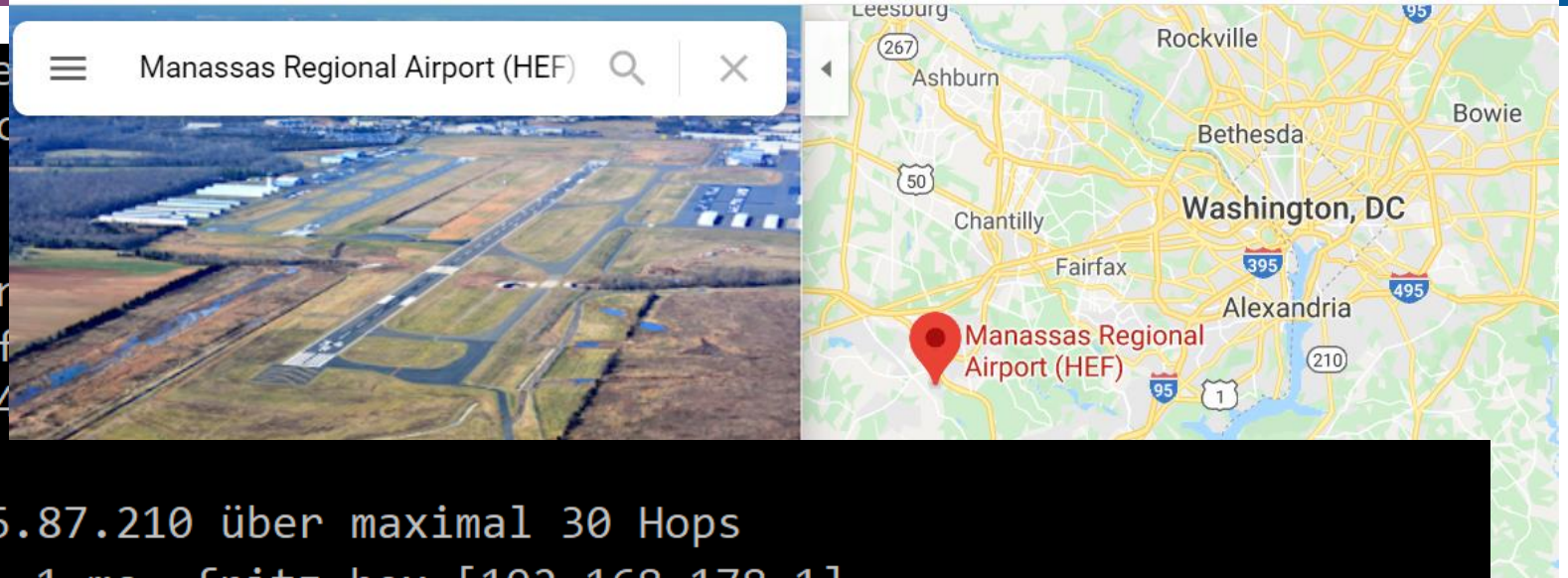

```
C:\>tracert 52.96.87.210
Routenverfolgung zu 52.96.87.210 über maximal 30 Hops

  1    2 ms    1 ms    1 ms    fritz.box [192.168.178.1]
  2    5 ms    4 ms    5 ms    p3e9bf2dc.dip0.t-ipconnect.de [62.155.242.220]
  3   12 ms   11 ms   12 ms    d-ed5-i.D.DE.NET.DTAG.DE [62.154.5.213]
  4   12 ms   12 ms   12 ms    80.157.204.58
  5   16 ms   15 ms   16 ms    ae18.cr3-ams1.ip4.gtt.net [213.200.117.218]
  6   16 ms   16 ms   16 ms    ip4.gtt.net [154.14.37.246]
  7   16 ms   16 ms   16 ms    ae25-0.icr01.ams21.ntwk.msn.net [104.44.239.75]
  8   97 ms   96 ms   96 ms    be-100-0.ibr01.ams21.ntwk.msn.net [104.44.22.235]
  9   97 ms   96 ms   96 ms    be-8-0.ibr01.dub08.ntwk.msn.net [104.44.19.212]
 10   97 ms   96 ms   96 ms    be-7-0.ibr01.sx171.ntwk.msn.net [104.44.16.116]
```



Validation

- Make sure that the clients use the „right DNS-Server“
- Watch for
 - DNS-Servers in the wrong region
 - DNS-Forwarding from location to headquarter
 - „optimizing“ servers (PiHole etc)
 - „Hosted“ Filter-Services
 - Cloud Proxy
 - IPv6 and VPN
- DNS and VPN: Name Resolution Policy Table?
- DNS Resolution should follow packet routing

- Anycast IP Routing

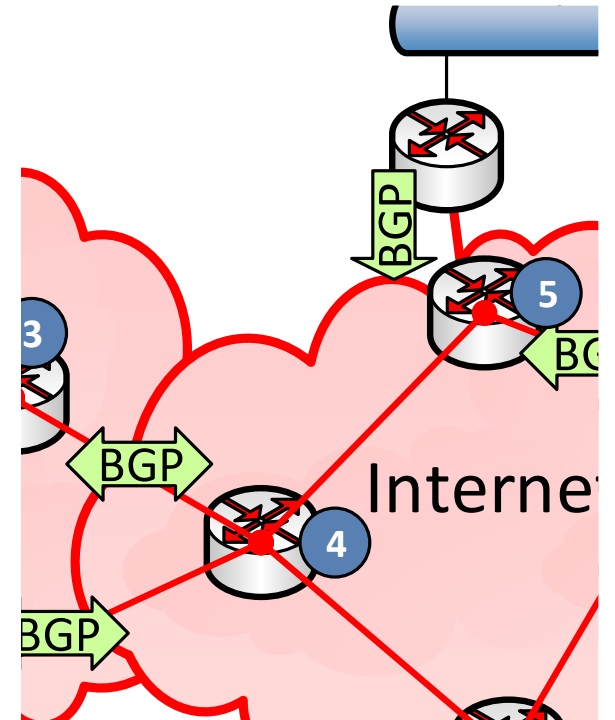



Redundant IP-Routing

Redundant routing

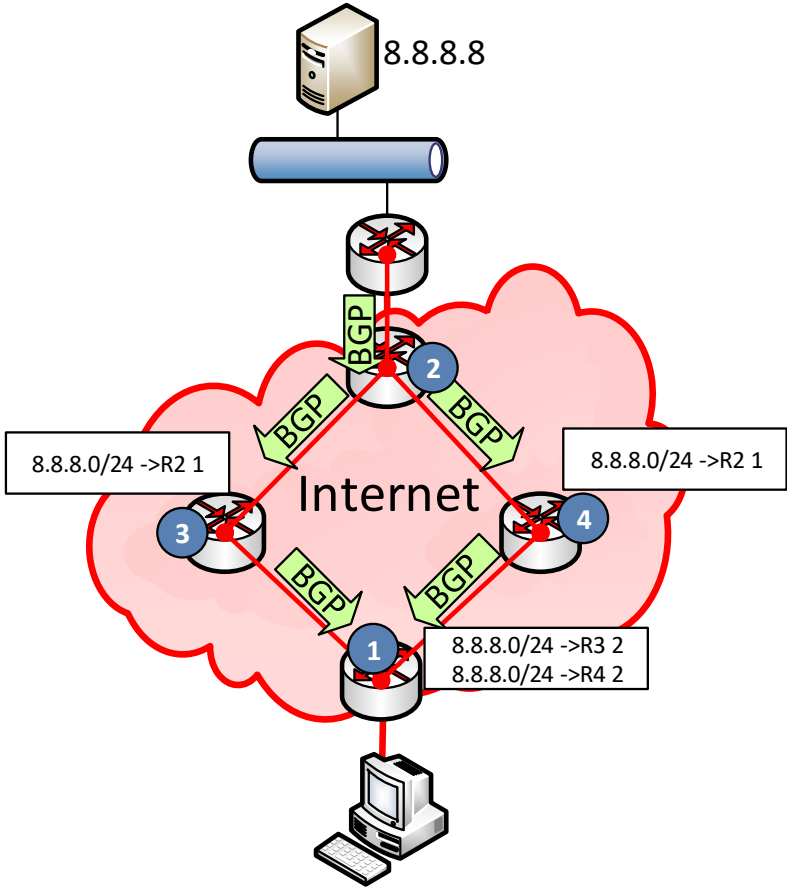

Redundant provider

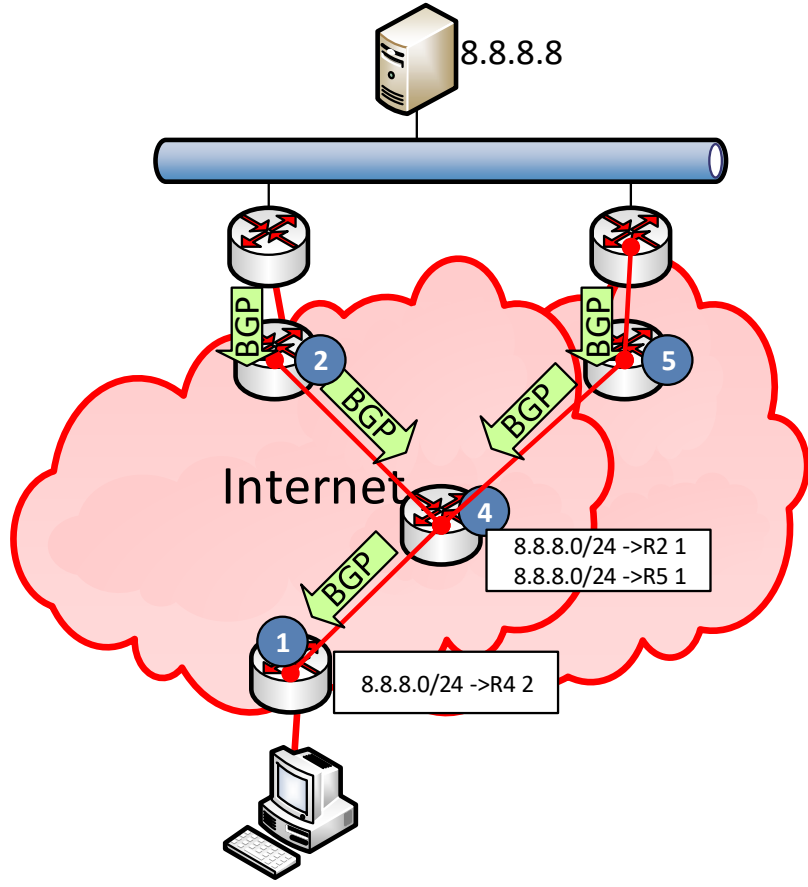

Anycast IP

- Multiple servers
- Identical services
- Distributed locations
- Announced by BGP etc.
- Is not „Geo-DNS“
- High available
- High scalability
- „nearest Server“

„fixing“ a wrong DNS configuration?

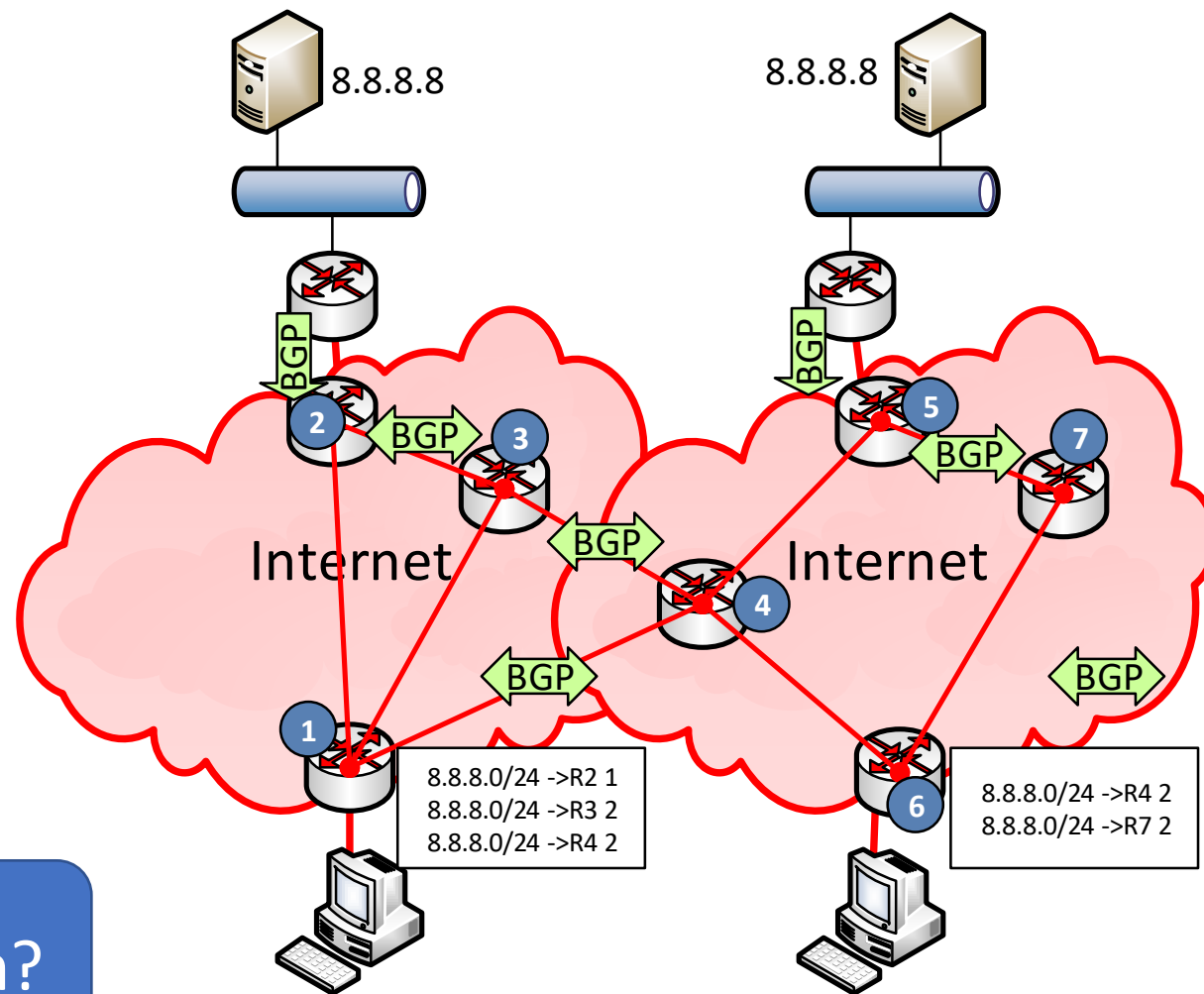



DNS by Microsoft 365 Service

	Name	IP	Target
Exchange Online	GeoDNS outlook.office365.com AnyCast-DNS (partial) outlook.office.com	AMS-efz.ms-acdc.office.com FRA-efz.ms-acdc.office.com LHR-efz.ms-acdc.office.com SFX-efz.ms-acdc.office.com SJC-efz.ms-acdc.office.com CPQ-efz.ms-acdc.office.com	Different entry points
SharePoint/OneDrive	Anycast DNS <tenant>.sharepoint.com <tenant>-my.sharepoint.com	spo-0004.spo-msedge.net	13.107.136.9
Teams HTTP	Anycast DNS teams.microsoft.com	s-0005.s-msedge.net o.a.	52.113.194.132 2620:1ec:42::132
Teams RTP	GeoDNS worldaz.tr.teams.microsoft.com	To much and very short TTL	13.107.64.0/18 52.112.0.0/14 52.120.0.0/14
SfB Online Edge	IP-Adresses as part of the SDP	No DNS, Inband	obsolet

- TCP Level 400



- Windows Size
- Port-Limits
- TCP-Chimney
- Window size / RSS
- SACK

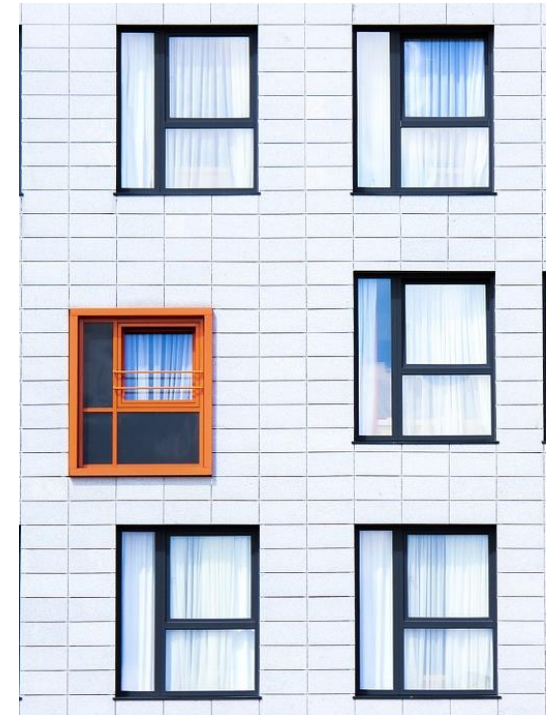

You all should know this already – but it is not present



LATENCY AND THROUGHPUT

Big-Fat-Pipe problem and latency

- 1x PC + 1x Server
 - CPU unlimited
 - Disk unlimited
 - LAN Unlimited
- 1x WAN-Link
 - „Unlimited“ Bandwidth
 - 20ms Roundtrip Time



Quiz: Maximum throughput with single FTP transfer

- ≤ 1 MBit
- 1-10 MBit
- 10-100 MBit
- >100 MBit

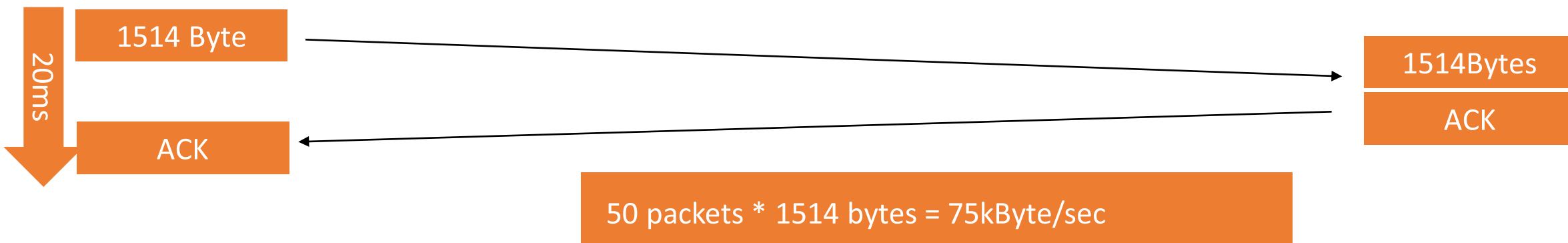

Windows Scaling and latency

- Send multiple packets as block and accept later ACK-packets
 - Sender and receiver must maintain a buffer to resend lost packet and reassemble reordered packets
 - Negotiation of buffersize required: (max. 1 GB, Win2008: 16MB)
 - „RFC1323 TCP Extensions for High Performance“
 - Selective Ack (SACK)

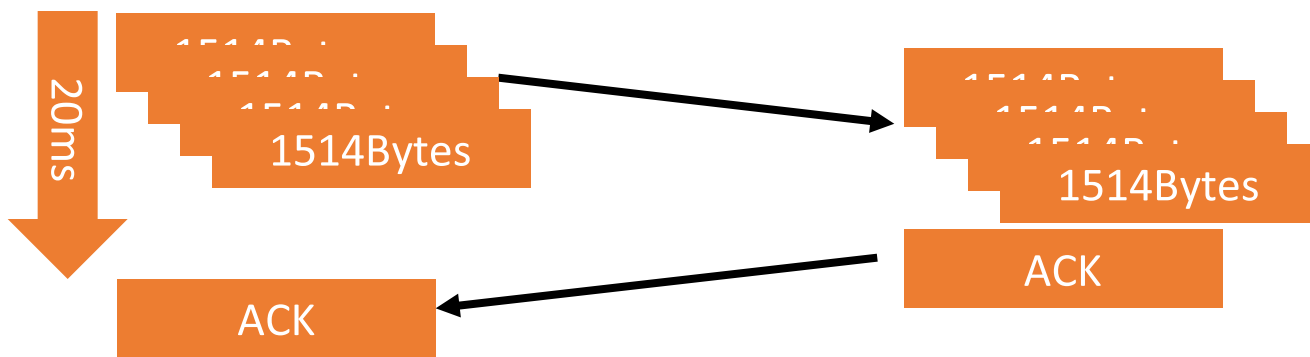

[https://docs.microsoft.com/en-us/previous-versions/technet-magazine/cc162519\(v=msdn.10\)](https://docs.microsoft.com/en-us/previous-versions/technet-magazine/cc162519(v=msdn.10))
https://www.msxfaq.de/netzwerk/grundlagen/tcp_retransmit_und_sack.htm

```
> Frame 885: 271 bytes on wire (2168 bits), 271 bytes captured
> Ethernet II, Src: Portwell_49:4f:68 (00:90:fb:49:4f:68), Dst:
> Internet Protocol Version 4, Src: 40.97.134.18, Dst: 192.168
v Transmission Control Protocol, Src Port: 443, Dst Port: 4987
    Source Port: 443
    Destination Port: 49870
    [Stream index: 28]
    [TCP Segment Len: 217]
    Sequence number: 5544 (relative sequence number)
    [Next sequence number: 5761 (relative sequence number)]
    Acknowledgment number: 2783 (relative ack number)
    0101 .... = Header Length: 20 bytes (5)
    > Flags: 0x018 (PSH, ACK)
    Window size value: 65535
    [Calculated window size: 1048560]
    [Window size scaling factor: 16]
    Checksum: 0x8fa4 [unverified]
    [Checksum Status: Unverified]
```



Window size and Latenz = Throughput

Applikation	Window size	1ms	20ms	50ms	100ms	200ms
Exchange Webservices (EWS)	1.048.560	na	50MB/s	20MB/s	10MB/s	5MB/s
OneDrive 10MB Upload	1.059.840	na	50MB/s	20MB/s	10MB/s	5MB/s
SharePoint 12MB Download	4.273.920	na	208MB/s	84MB/s	42MB/s	21MB/s
End2end-http Outlook	1.588.480	na	75MB/s	30MB/s	15MB/s	7,5MB/s
Outlook Client	525.568	na	25MB/s	10MB/s	5MB/s	2,5MB/s
SFTP using SSH 1and1	131584	na	6MB/s	2,4MB/s	1,2MB/s	660kB/s
SMB im LAN	2.102.272	GB+	na	na	na	na

These are „real world“ values, measured with WireShark.
Have you checked your values? Some firewalls are „adjusting“ them





PACKETLOSS AND THROUGHPUT



Paket Loss affects throughput

- Why Packetloss
 - Link-Congestion
 - Queue-overflow
 - Rare: electrical issues
- TCP-Stack: Recipient
 - Stop delivery
 - Request retransmit
- TCP-Stack: Sender
 - Retransmit lost packet
 - Throttle down send rate
- VoIP ?
 - UDP preferred – no retransmit
 - RTCP-Message to sender
 - Adapt Bitrate (less fps)
 - Change codec (wideband to narrowband)

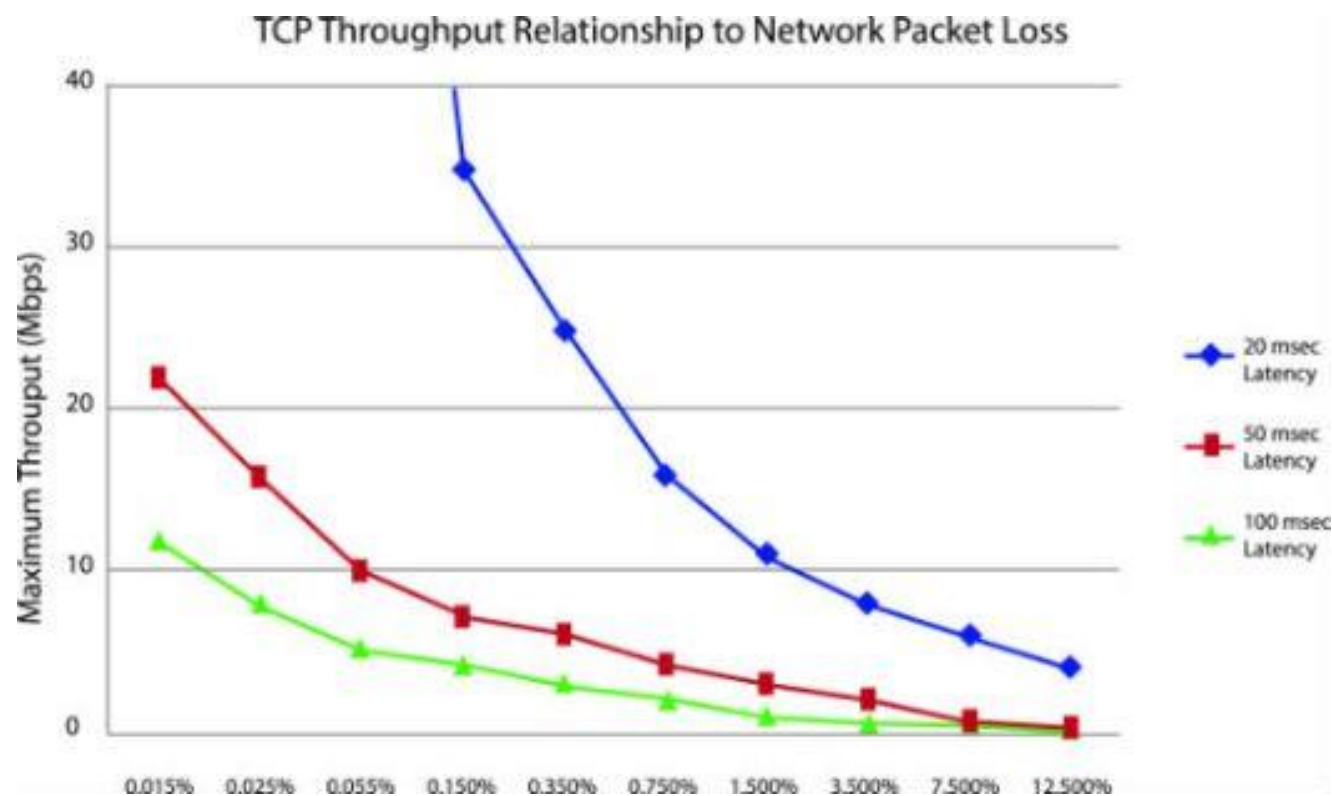

Source: <https://telnetnetworks.wordpress.com/tag/packet-loss/>

Quiz: Bandwidth policies and firewall

- Given situation: limited bandwidth. Can i control „downstream“?
 - I can control and prioritize outbound traffic
 - But do i need my ISP to optimize inbound traffic?

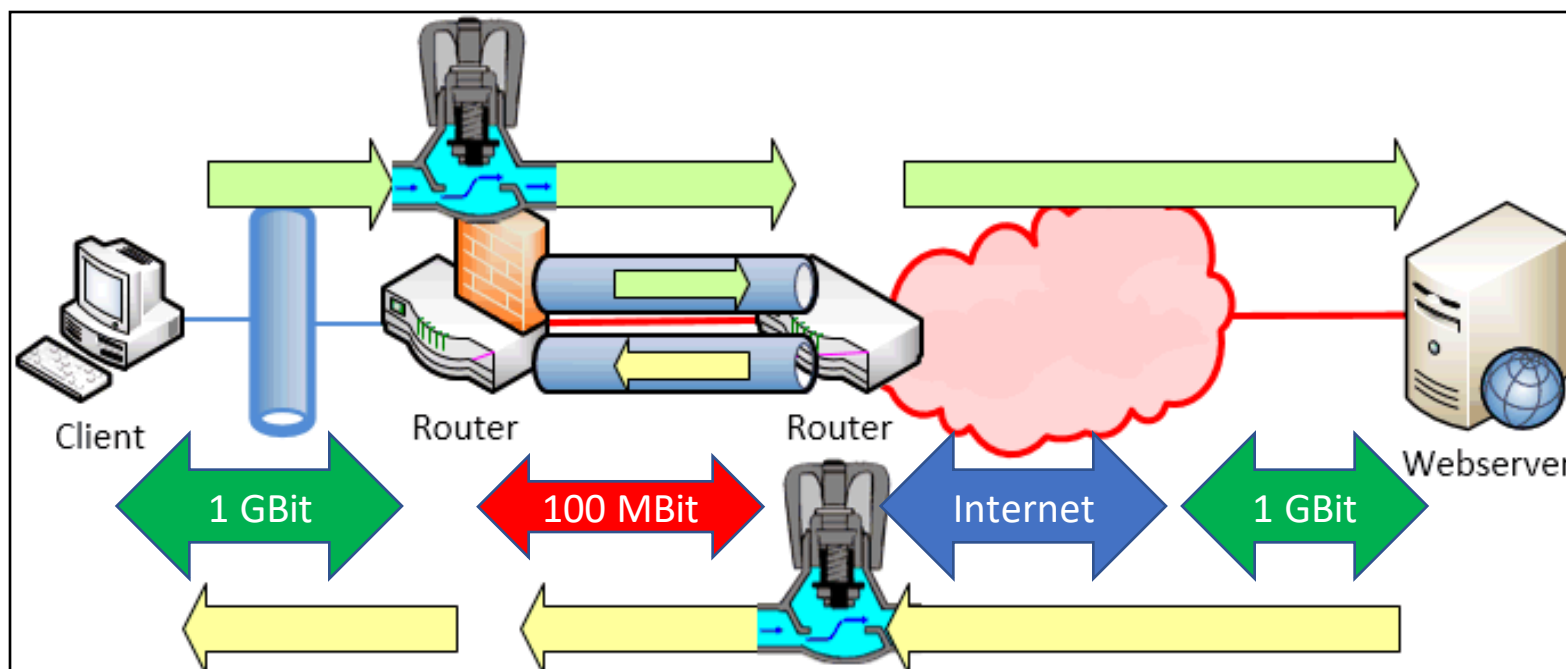

A Firewall can throttle TCP-ACK to limit inbound rate.





MTU AND ICMP BLOCKING



MTU and ICMP

- Maximum and Minimum Packetsize
 - Attn. DSLite
 - Attn. Azure VPN
https://www.msxfaq.de/cloud/azure/azure_vpn_und_mtu.htm
- Fragmentation
 - Ineffective, should not happen
 - IPv6 no fragmentation!
 - ICMP „Exceeded“ Meldung
- Best Practice
 - Let endpoint negotiate the maximum packet size
 - ICMP (Typ=3, Code=4) required

```

> Frame 1: 1514 bytes on wire (12112 bits), 1514 bytes captured
> Ethernet II, Src: Universa_5d:79:e1 (e0:4f:43:5d:79:e1),
  Dst: 08:00:27:00:00:00 (08:00:27:00:00:00)
  > Internet Protocol Version 4, Src: 192.168.178.50, Dst: 192.168.178.1
    0100 .... = Version: 4
    .... 0101 = Header Length: 20 bytes (5)
    > Differentiated Services Field: 0x00 (DSCP: CS0, ECN: Not-ECT)
      Total Length: 1500
      Identification: 0xdd86
    > Flags: 0x4000, Don't Fragment
      Time to live: 128
      Protocol: ICMP (1)
      Header checksum: 0x0000 [Header checksum status: Good]

```

Medium	Typ
Ethernet	1492
DSL	1464
Internet DSLite	1472
Freifunk/AzureVPN	1372

```

> Frame 422: 70 bytes on wire (560 bits), 70 bytes captured on interface
> Ethernet II, Src: AvmAudio_98:0c:97 (e0:28:6d:98:0c:97), Dst: 08:00:27:00:00:00
  > Internet Protocol Version 4, Src: 46.91.217.151, Dst: 192.168.178.50
  > Internet Control Message Protocol
    Type: 3 (Destination unreachable)
    Code: 4 (Fragmentation needed)
    Checksum: 0x510e [correct]
    [Checksum Status: Good]
    Unused: 0000
    MTU of next hop: 1492
  > Internet Protocol Version 4, Src: 192.168.178.50, Dst: 46.91.217.151
    Sequence number (LE): 1472
    [Response frame: 2]
    > Data (1472 bytes)

```

FRITZ!Box 7490

Internet > Zugangsdaten

Internetzugang | IPv6 | LISP

Bestimmte Länge für das LAN-Präfix anfordern

Länge Bit

Weitere Einstellungen

MTU manuell einstellen Byte



MTU – Real customer case

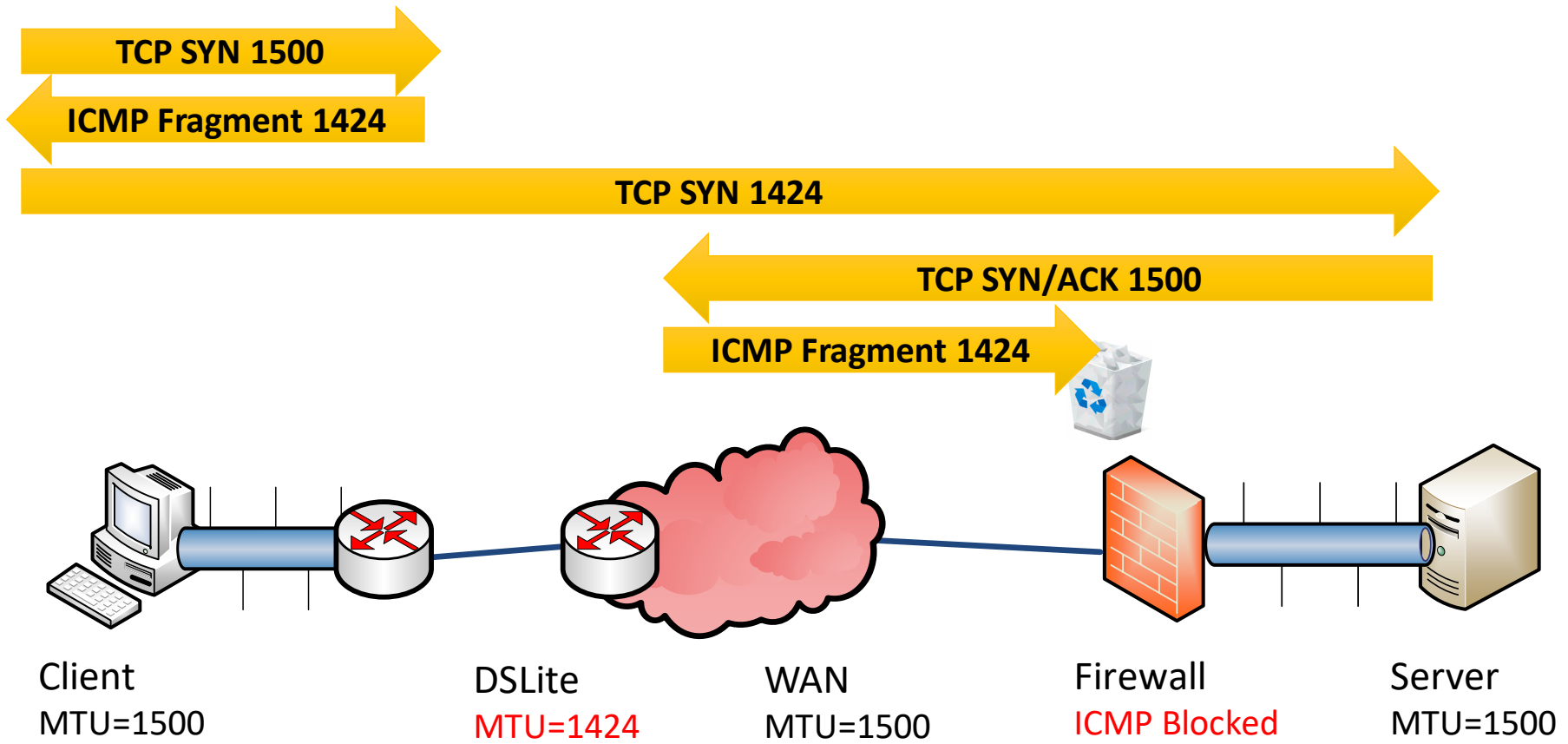

- TCP/IP and Ports

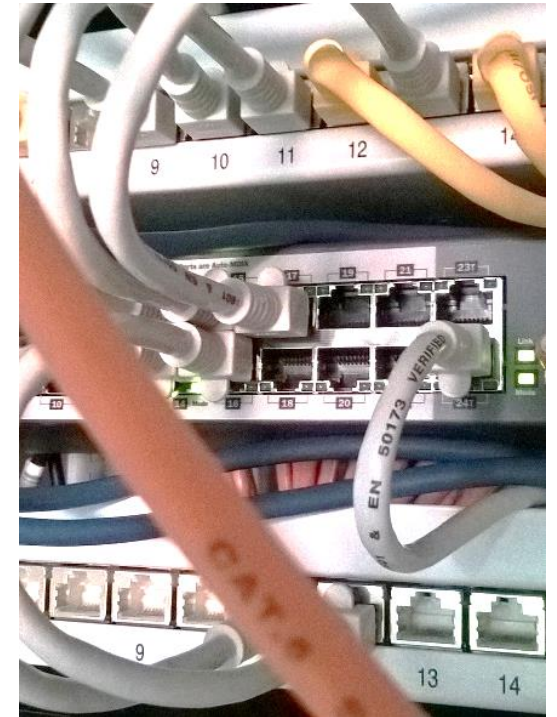

You all should know this already – but it is not present, Part 2



Latenz per Connection -> more connections

- Sample Outlook
- Sample Teams

TCP-Verbindungen							
Gefiltert von "OUTLOOK.EXE, Teams.exe, Teams.exe"							
Prozess	PID	Lokale Adresse	Lokale...	Remoteadresse	Remoteport	Paketverlust (%)	Latenz (ms)
Teams.exe	14412	172.18.241.38	58440	52.114.128.13	443	0	414
Teams.exe	14412	172.18.241.38	58439	52.114.88.46	443	0	76
Teams.exe	13952	172.18.241.38	58447	52.114.74.39	443	0	74
Teams.exe	14412	172.18.241.38	58457	52.178.94.2	443	-	-
Teams.exe	13952	172.18.241.38	58448	52.113.194.131	443	-	-
Teams.exe	14412	172.18.241.38	58435	52.113.194.131	443	-	-
Teams.exe	13952	172.18.241.38	58417	52.114.76.35	443	-	-
OUTLOOK.EXE	22632	172.18.241.38	58520	40.101.12.18	443	0	1.190
OUTLOOK.EXE	22632	172.18.241.38	58519	40.101.12.18	443	0	567
OUTLOOK.EXE	22632	172.18.241.38	58507	40.101.12.18	443	0	553
OUTLOOK.EXE	22632	172.18.241.38	58499	40.101.12.18	443	0	523
OUTLOOK.EXE	22632	172.18.241.38	58517	40.101.12.18	443	0	491
OUTLOOK.EXE	22632	172.18.241.38	58497	40.101.12.18	443	0	490
OUTLOOK.EXE	22632	172.18.241.38	58493	40.101.12.18	443	0	461
OUTLOOK.EXE	22632	172.18.241.38	58506	52.114.76.35	443	0	420
OUTLOOK.EXE	22632	172.18.241.38	58487	40.101.12.18	443	0	397
OUTLOOK.EXE	22632	172.18.241.38	58490	40.101.12.18	443	0	342
OUTLOOK.EXE	22632	172.18.241.38	58485	40.101.12.18	443	0	318
OUTLOOK.EXE	22632	172.18.241.38	58521	40.101.12.18	443	0	301
OUTLOOK.EXE	22632	172.18.241.38	58510	40.101.12.18	443	0	272
OUTLOOK.EXE	22632	172.18.241.38	58503	40.101.12.18	443	0	188
OUTLOOK.EXE	22632	172.18.241.38	58486	40.101.12.18	443	0	186
OUTLOOK.EXE	22632	172.18.241.38	58501	40.101.12.18	443	0	182

VID	SMTP-Adresse	Servername	Status	Proto...	Authn	Verschl...	Typ	Anfr/Fehle
		365.com/...	hergestellt	HTTP	Träger*	SSL	Exchange-Verzei...	60/3
		365.com/...	hergestellt	HTTP	Klartext*	SSL	Exchange-Verzei...	58/2
		365.com/...	hergestellt	HTTP	Träger*	SSL	Exchange-Verzei...	376/4
		365.com/...	hergestellt	HTTP	Klartext*	SSL	Exchange-Verzei...	63/2
		365.com/...	hergestellt	HTTP	Träger*	SSL	Exchange-E-Mail	3913/4
		k.de/map...	hergestellt	HTTP	Nego*	SSL	Exchange-E-Mail	90/11
		365.com/...	hergestellt	HTTP	Träger*	SSL	Exchange-E-Mail	14711/6
		365.com/...	hergestellt	HTTP	Klartext*	SSL	Exchange-E-Mail	169/5
		365.com/...	hergestellt	HTTP	Klartext*	SSL	Exchange-E-Mail	783/4
		365.com/...	hergestellt	HTTP	Träger*	SSL	Exchange-E-Mail	173/2
		k.de/map...	hergestellt	HTTP	Nego*	SSL	Exchange-E-Mail	113/13
		365.com/...	hergestellt	HTTP	Klartext*	SSL	Exchange-E-Mail	64/6
		365.com/...	hergestellt	HTTP	Träger*	SSL	Exchange-E-Mail	72/3
		365.com/...	hergestellt	HTTP	Träger*	SSL	Exchange-E-Mail	97/4
		365.com/...	hergestellt	HTTP	Klartext*	SSL	Exchange-E-Mail	2470/6
		365.com/...	hergestellt	HTTP	Träger*	SSL	Exchange-E-Mail	12/0

Private addresses and public ports

- We need a translation from private IP to internet services
 - NAT-Device or HTTP-Proxy

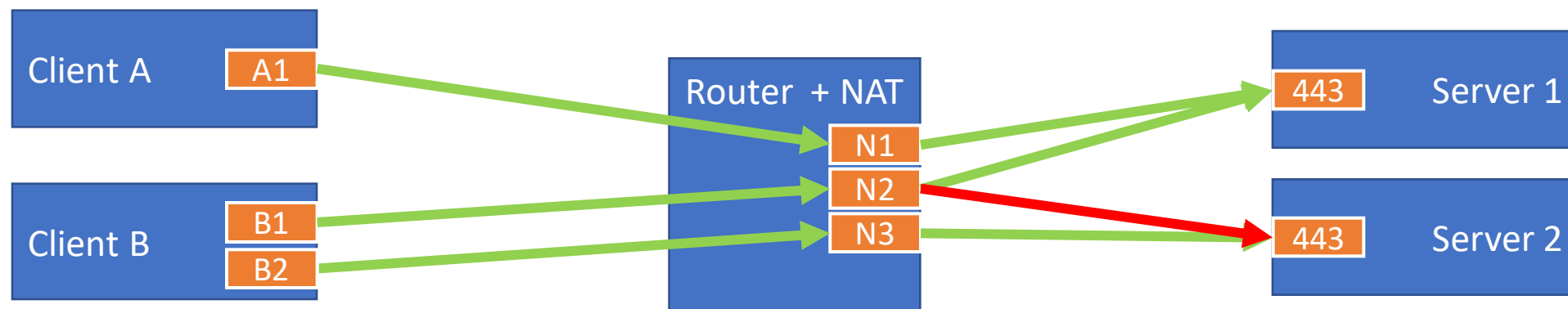

- Questions
 - How many outgoing connections per IP-Address?
 - How many connections are „typical“ per client ?
- Microsoft estimation
 - 6 ports/client + 4 ports „peak“ = 10 ports/client
 - 64000 Ports per NAT-Device – 4000 reserved = 60.000 Ports for Clients



Session Timeout / Keepalive

- Clients are not friendly
 - Client loses WLAN-Connection
 - Client removed from the docking unit
 - NAT-Session stays active for how long ?
- TCP Session Timeout
 - Min 120 Seconds. Not shorter
 - „Long running connections“
 - HTTP-Chunked-connections
- Action: Monitor connections

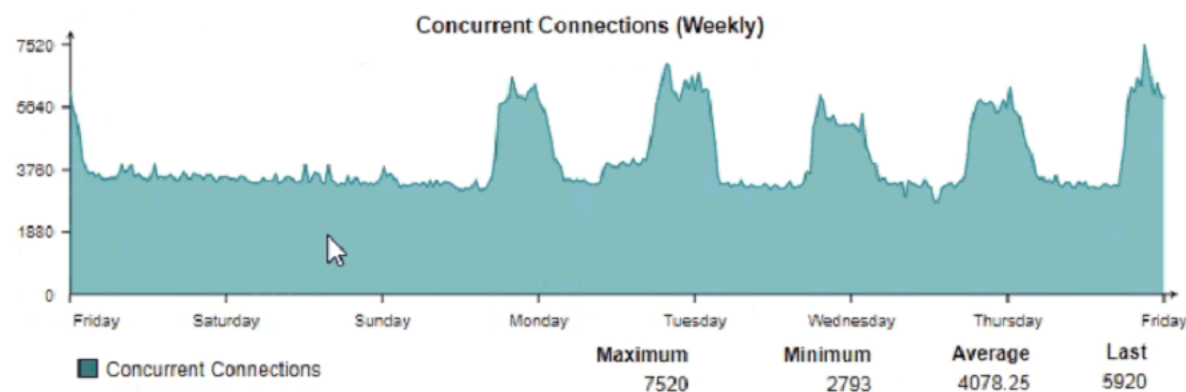
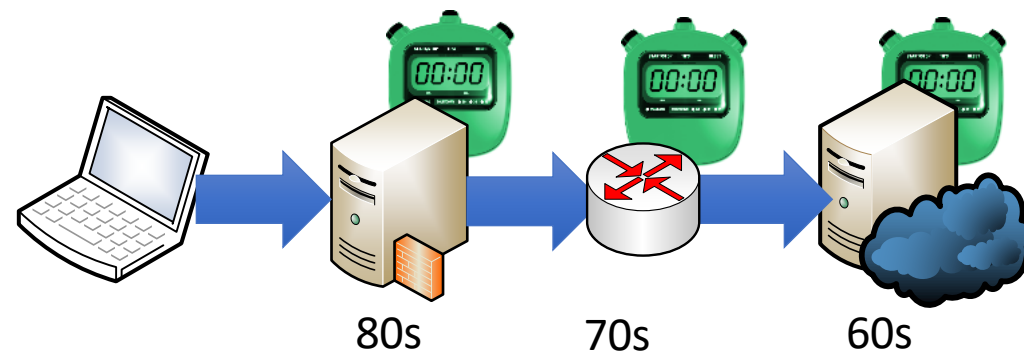

TCP keep-alives can be sent once every KeepAliveTime (defaults to 7,200,000 milliseconds or two hours) if no other data or higher-level keep-alives have been carried over the TCP connection.

<https://blogs.technet.microsoft.com/nettracer/2010/06/03/things-that-you-may-want-to-know-about-tcp-keepalives/>

https://www.msxfaq.de/netzwerk/grundlagen/tcp_session_timeout.htm

<https://blogs.technet.microsoft.com/onthewire/2014/03/04/network-perimeters-tcp-idle-session-settings-for-outlook-on-office-365/>

- Teams realtime traffic protocol (RTP)





Audio and Video with Teams

- Audiostream
 - 20ms „audio“ per packet (2st hop Latency!)
 - 50 packets/sec
 - About 160Byte payload (64kbit)
 - 100kbit/Sec continuous stream
- Preferred protocol: UDP!
 - Ask your firewall guys!
- Max Latency: 100ms
- Packetloss and RTP

Firewall and proxy requirements

Microsoft Teams connects to Microsoft Online Services and needs internet connectivity for this. For Teams to function correctly, you must open TCP ports 80 and 443 from the clients to the internet, and UDP ports 3478 through 3481 from the clients to the internet. The TCP ports are used to connect to web-based content such as SharePoint Online, Exchange Online, and the Teams Chat services. Plug-ins and connectors also connect over these TCP ports. The four UDP ports are used for media such as audio and video, to ensure they flow correctly.

Opening these ports is essential for a reliable Teams deployment. Blocking these ports is unsupported and will have an effect on media quality.

Source: <https://docs.microsoft.com/en-us/microsoftteams/3-envison-evaluate-my-environment#firewall-and-proxy-requirements>



Teams RTP requirements

- Latency, Loss

- Run the [network latency analytics tool](#) .
- Ping the Google Meet media front-end server for at least 5

```
> ping lens.1.google.com  
PING lens.1.google.com (74.125.143.127): 56 dat:  
64 bytes from 74.125.143.127: icmp_seq=0 ttl=47  
64 bytes from 74.125.143.127: icmp_seq=1 ttl=47  
64 bytes from 74.125.143.127: icmp_seq=2 ttl=47  
64 bytes from 74.125.143.127: icmp_seq=3 ttl=47  
64 bytes from 74.125.143.127: icmp_seq=4 ttl=47
```

Make sure your latency is consistent at 100 ms or less. Don't average the values because it can hide spikes and intermediate latency problems.

If your latency is not 100 ms or less, use the traceroute utility to print out the network path from your current machine to the Meet media front-end. This path should be as short as possible, for example:

Source:<https://support.google.com/a/answer/7582554?hl=en#zippy=%2Cmeasure-latency>

Metric	Edge	Client
Latency (one way)	< 30ms	< 50ms
Latency (RTT)	< 60ms	< 100ms
Burst packet loss	<1% during any 200 ms interval	<10% during any 200ms interval
Packet loss	<0.1% during any 15s interval	<1% during any 15s interval
Packet inter-arrival Jitter	<15ms during any 15s interval	<30ms during any 15s interval
Packet reorder	<0.01% out-of-order packets	<0.05% out-of-order packets

<https://docs.microsoft.com/de-de/skypeforbusiness/optimizing-your-network/media-quality-and-network-connectivity-performance#network-performance-requirements-from-your-network-edge-to-microsoft-network-edge>



Teams and Media

- 1:1 is easy
 - Direct UDP
 - Transport Relay
- Meeting uses MCU
 - Always using the transport Relay
 - „central Mixer“ is online
- Homeschooling
 - 1 teacher talking
 - nn students listening

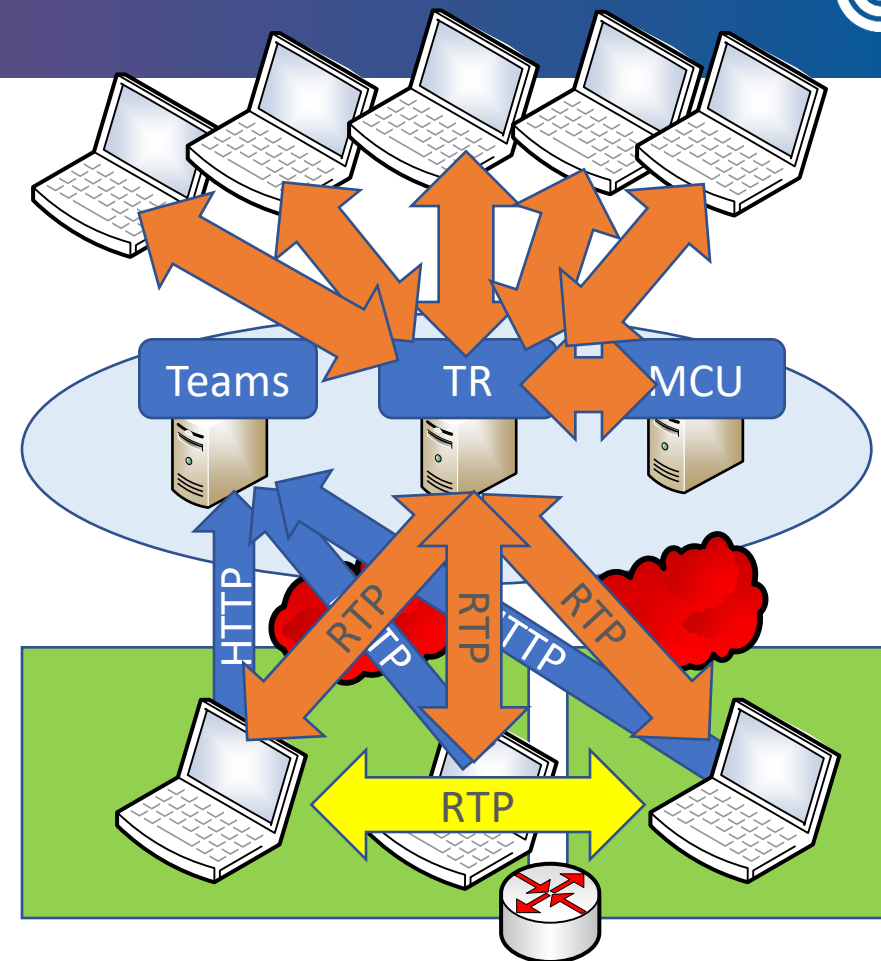

- From my firewall to Microsoft 365

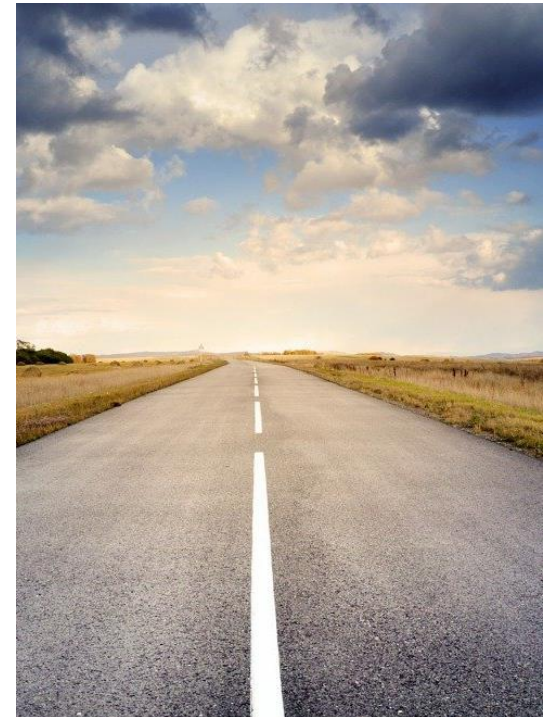

Local monitoring

- Own WAN network
 - 1 • Bandwidth via SNMP
 - NetFlow for details
- Internet
 - 2 • Bandwidth via SNMP
 - Proxylogs/URL-Logs
- Server
 - 3 • Perfmon
 - IIS-Logs
 - Eventlog
- Client Performance
 - 4 • Rare, most not used

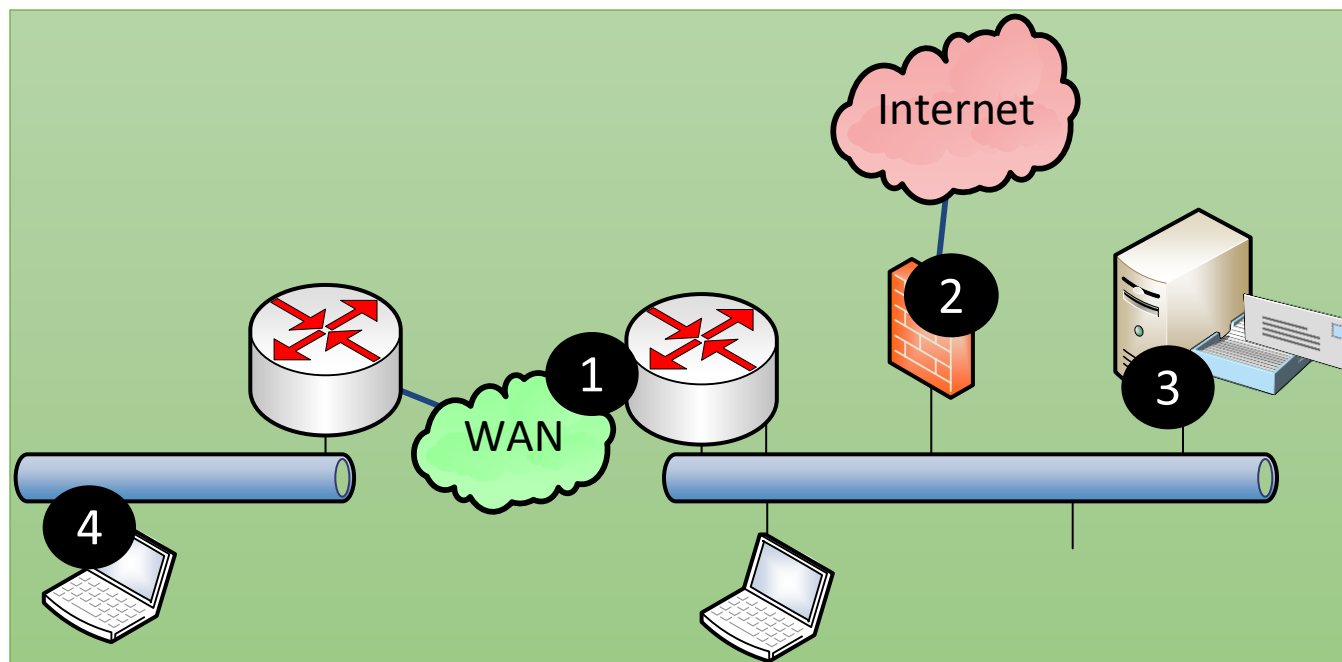

Everything under control?



Performance Monitoring with Cloud services

- 1 • Service are „outside“
 - Managed by Microsoft
- 2 • No relevant local traffic
 - Local breakout
 - bypass own WAN
- 3 • No details from ISP
- 4 • More „Internet Traffic“

Adjust your existing monitoring!

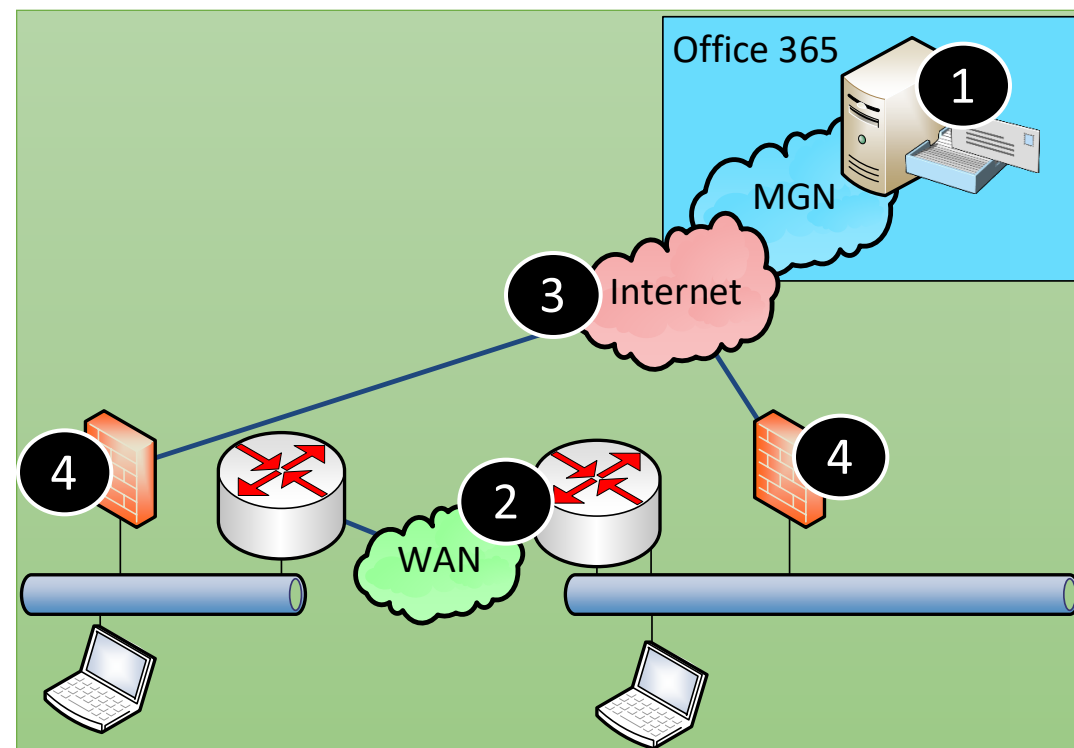

- Measure cloud performance, latency etc.

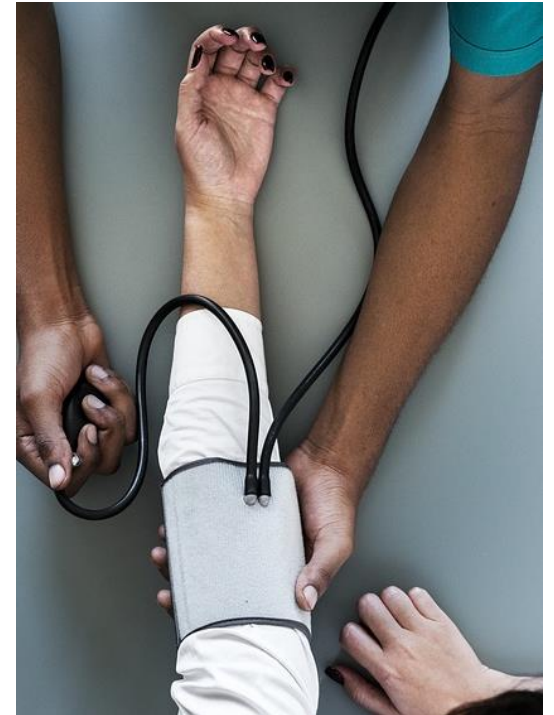



Common mistakes

- Latency vs. Bandwidth
 - 80% saturated line is not bad
 - If the latency is still low
 - High latency = not enough bandwidth „somewhere“
- Interval Seconds vs. Minutes
 - Don't measure a line every minute
 - You cannot „see“ RTP-Problems
- Average vs. Percentil
 - Do not measure averages
 - You cannot see spikes or high jitter
 - Think about percentil



What is Percentil?

- Think about a pizza service
 - „Expected average delivery Time is 10 minutes“
 - 50% withing 5 minutes and hot
 - 50% withing 15 minutes and cold
 - -> 50% unhappy customers
- „Average“ is the wrong approach
 - No distribution, no bursts
- Better
 - 95% of the pizzas are „hot enough“
 - max. 5% unsatisfied customers
- „Percentil“
 - Based on the requirements



Google: “Make sure your latency is consistent at 100ms or less. Don't average the values because it can hide spikes and intermediate latency problems.”

Quelle:

<https://support.google.com/a/answer/7582554>

- End2End-Scripts and Samples

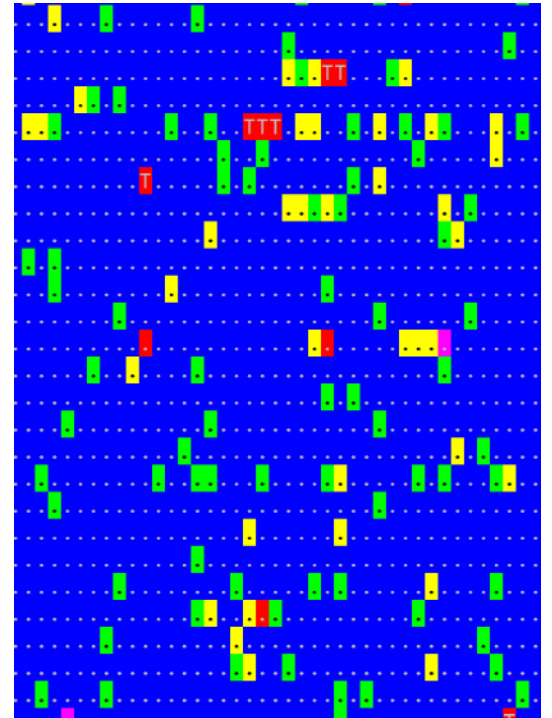

Remote endpoints



- Intermediate Systems
 - Routers
- Microsoft 365 –Services
 - Exchange Online
 - Teams Transport Relay
 - SharePoint
 - ...
- Other Cloud Dienste
 - Facebook, Twitter, Google,
- Own Services
 - Default Gateway, VPN-Server, RDP-Gateway, Company Portal,...

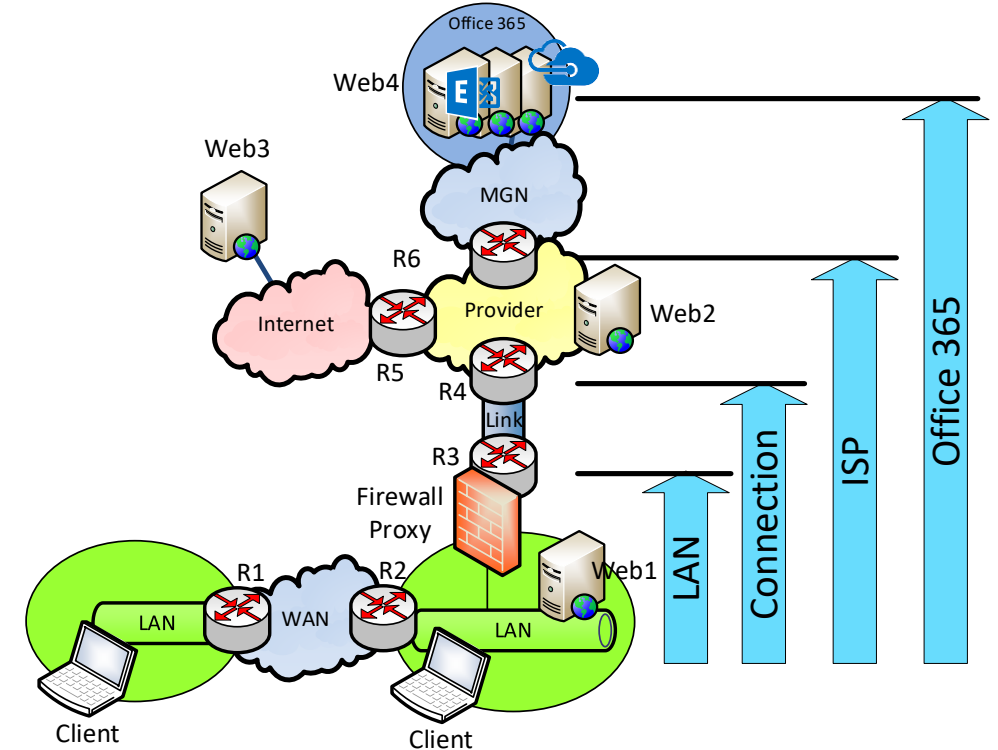

Samples: End2End-Ping

Bellevue Hotel 11:00pm/07:00am

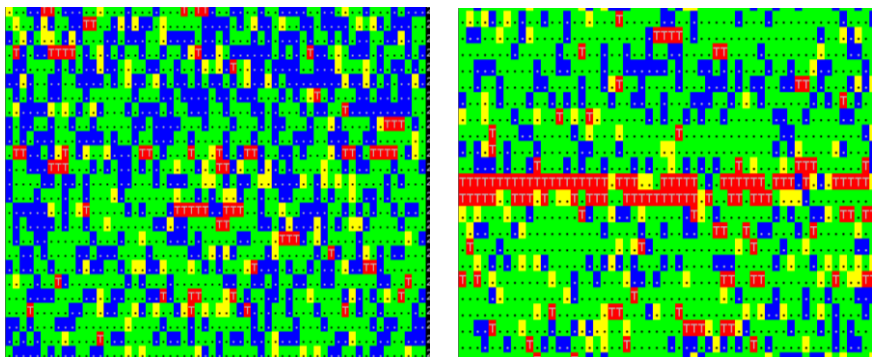

WifiOnICE

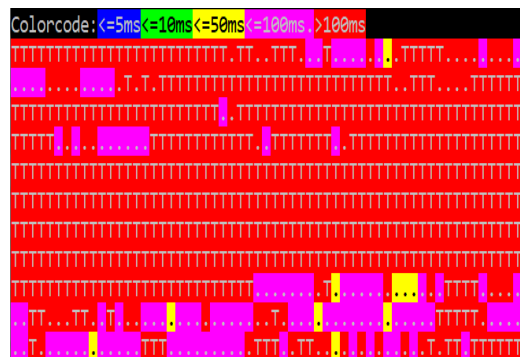

Home DSL 16/1

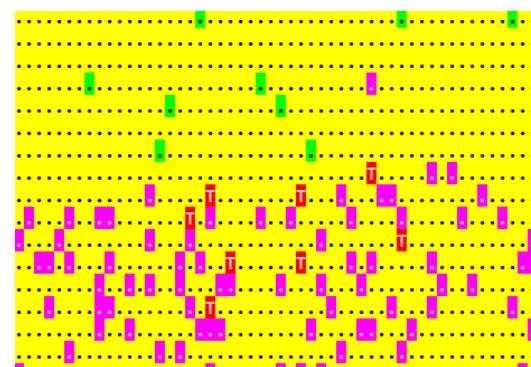

Hotel Frankfurt 01:00am, 07:00

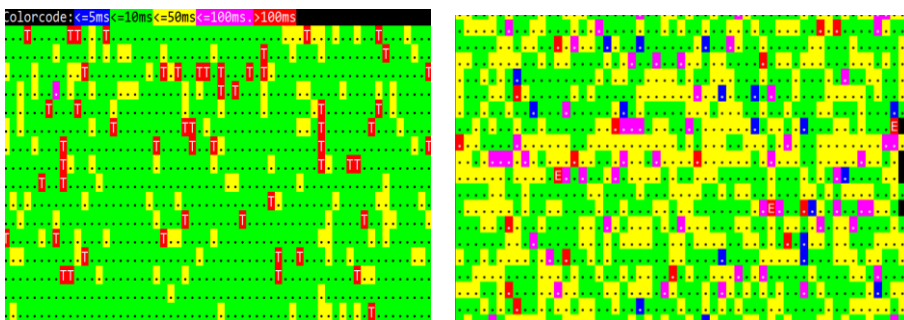

MSTFGuest (Internet / Office365)

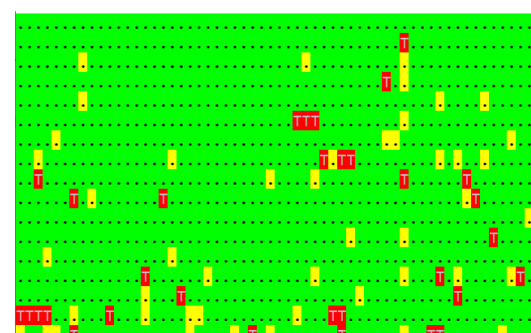
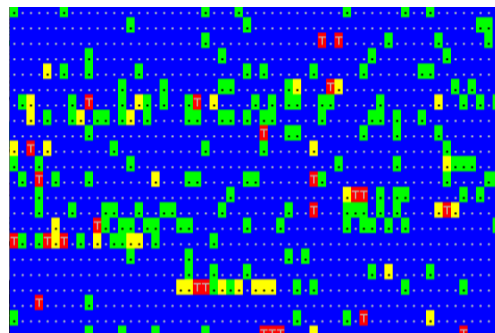



Checking HTTP

- We need a remote „valid“ endpoint.
 - No authentication
 - No Throttling

Bereich	URL	Size
Exchange	https://outlook.office365.com/owa/favicon.ico	7886 Bytes
Exchange	https://outlook.office365.com/owa/smime/owasmime.msi	729088 Bytes
OneDrive	<a href="https://<tenant>-my.sharepoint.com/">https://<tenant>-my.sharepoint.com/	193 Bytes
SharePoint	<a href="https://<tenant>.sharepoint.com/">https://<tenant>.sharepoint.com/	190 Bytes
SharePoint	<a href="https://<tenant>.sharepoint.com/_layouts/15/SPAndroidAppManifest.aspx">https://<tenant>.sharepoint.com/_layouts/15/SPAndroidAppManifest.aspx	308 Bytes
EvoSTS	https://login.microsoftonline.com/common/oauth2/authorize	138361 Bytes

- Easy to test (Invoke-WebRequest)
 - Parameter -UseBasicParsing and -MaxRedirects 0
 - Disable processindicator `$ProgressPreference="SilentlyContinue"`
 - Use Method HEAD instead of GET (smaller Paket)

End2End-http: favicon.ico

Frankfurt Hotel 01:00am/07:00am

Bellevue Hotel 01:00am / 07:00p

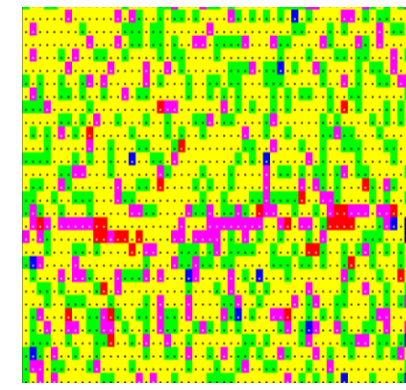
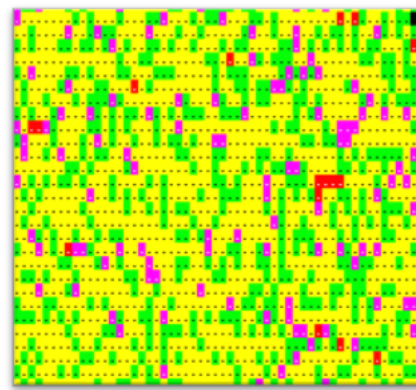
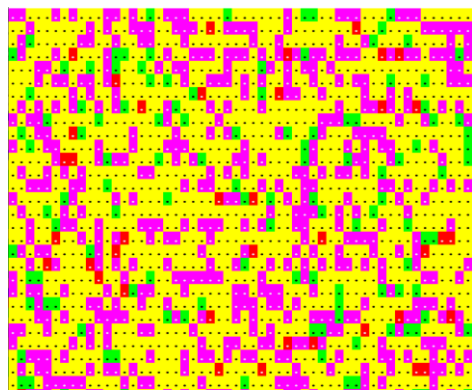
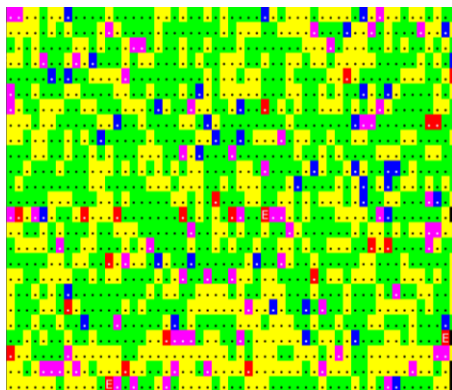

Compare to ICMP

Compare to ICMP

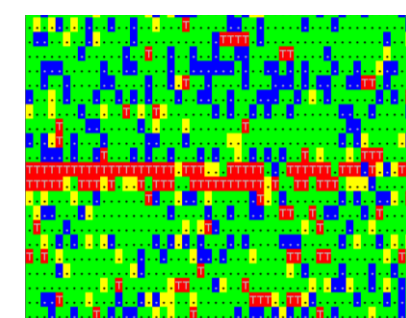
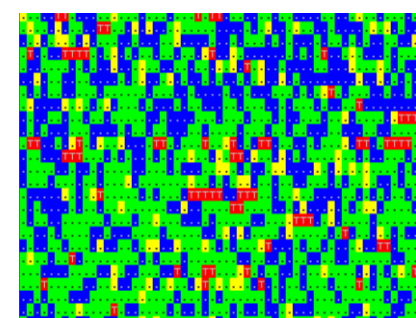
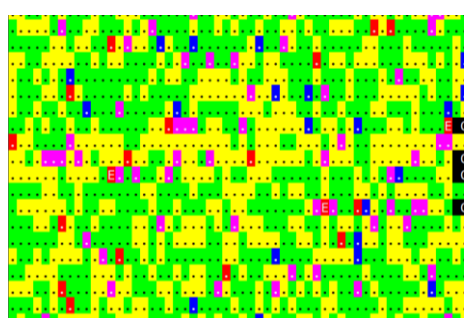
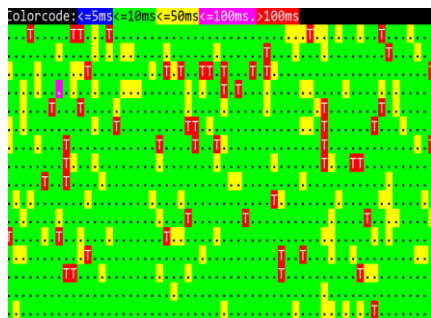



End2end-http with 700k-file

- 700kByte in 105ms = ca. 66 Mbit !
- 700kByte in 5652 sec = ca. 1,3 Mbit
 - Packetloss? Parallel PING?
- Color coding not optimal
- Looks like a DoS

```
End2End-HTTP: URL = https://outlook.office365.com/owa/smime/owasmime.msi
Colorcode: <=20ms <=50ms <=100ms <=200ms . >200ms
..... OK=27 Slow=9 Fail=0 MIN=153 AVG=692ms MAX=4251 X=End
..... OK=37 Slow=3 Fail=0 MIN=168 AVG=602ms MAX=5652 X=End
..... OK=42 Slow=2 Fail=0 MIN=156 AVG=354ms MAX=1388 X=End
..... OK=44 Slow=2 Fail=0 MIN=108 AVG=302ms MAX=1567 X=End
..... OK=48 Slow=1 Fail=0 MIN=123 AVG=222ms MAX=1012 X=End
..... OK=45 Slow=1 Fail=0 MIN=124 AVG=302ms MAX=1131 X=End
..... OK=42 Slow=2 Fail=0 MIN=105 AVG=346ms MAX=2217 X=End
..... OK=43 Slow=2 Fail=0 MIN=116 AVG=329ms MAX=1717 X=End
..... OK=46 Slow=0 Fail=0 MIN=131 AVG=278ms MAX=995 X=End
..... OK=35 Slow=5 Fail=1 MIN=150 AVG=405ms MAX=1053 X=End
```



HTTP and Exchange

Response Headers

HTTP/1.1 200 OK

Cache

Cache-Control: private

Date: Mon, 18 Mar 2019 12:22:08 GMT

Vary: Accept-Encoding

Cookies / Login

Set-Cookie: exchangecookie=ff2d2bf560141d3a294a087ecc2b87e; path=/
Set-Cookie: ExchangeAuthAs=Anonymous; path=/

Entity

Content-Length: 3547

Content-Type: text/xml; charset=utf-8

Miscellaneous

request-id: ab475c60-41d4-44d5-bd68-38c8804ba5e0

Server: Microsoft-IIS/10.0

X-AspNet-Version: 4.0.30319

X-BackendHttpStatus: 200

X-BackendHttpStatus: 200

X-BEServer: AM6PR04MB5013

X-BeSKU: WCS5

X-CalculatedBETarget: AM6PR04MB5013.eurprd04.prod.outlook.com

X-CalculatedFETarget: AM6PR0402CU001.internal.outlook.com

X-DiagInfo: AM6PR04MB5013

x-EwsHandler: FindItem

X-FEProxyInfo: AM6PR0402CA0034.EURPRD04.PROD.OUTLOOK.COM

X-FEServer: AM6PR0402CA0034

X-FEServer: MWHPR2201CA0074

X-Powered-By: ASP.NET

X-RUM-Validated: 1

Anzahl von Sitecode nach Tag und Sitecode

Sitecode ● AM ● BE ● DB ● FR ● HE ● PR ● VE ● VI

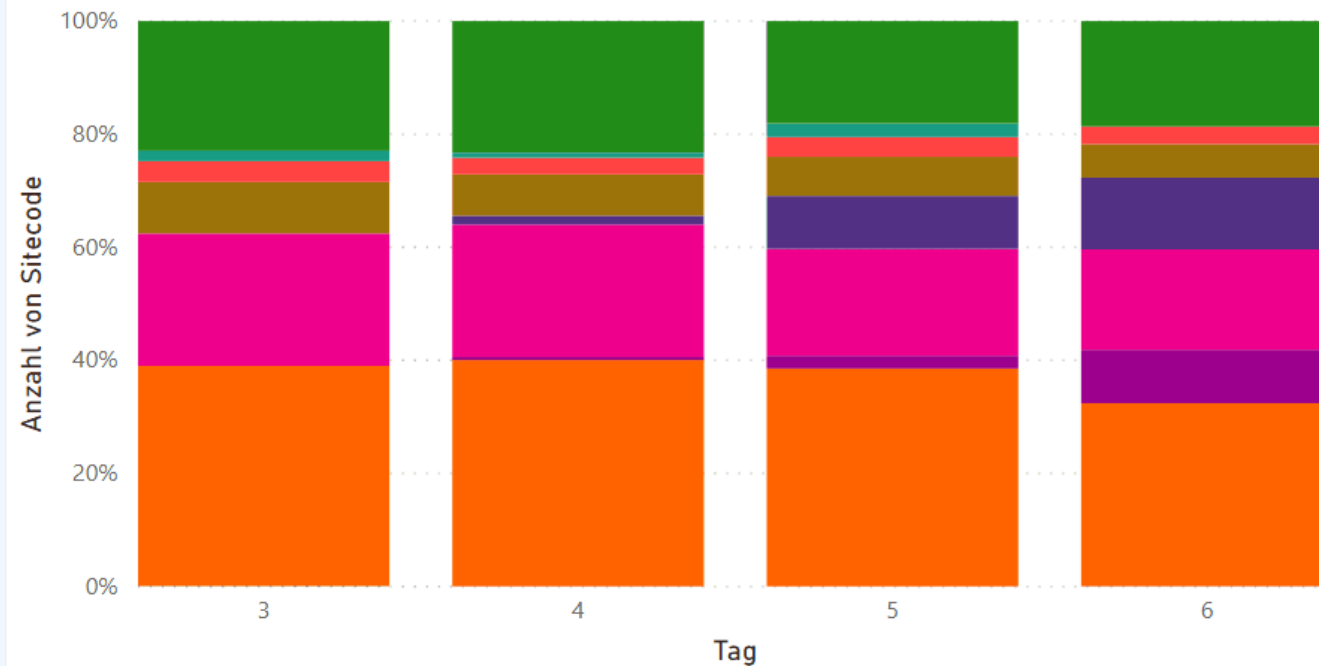



SharePoint Online

- URL
 - <tenantname>.sharepoint.com
 - <tenantname>-my.sharepoint.com
 - File: /_layouts/15/SPAndroidAppManifest.aspx).headers
- End2End-HTTP
 - Measure frontdoor access
 - Get „HealthScore“

Anzahl von Sphealthscore nach Sphealthscore

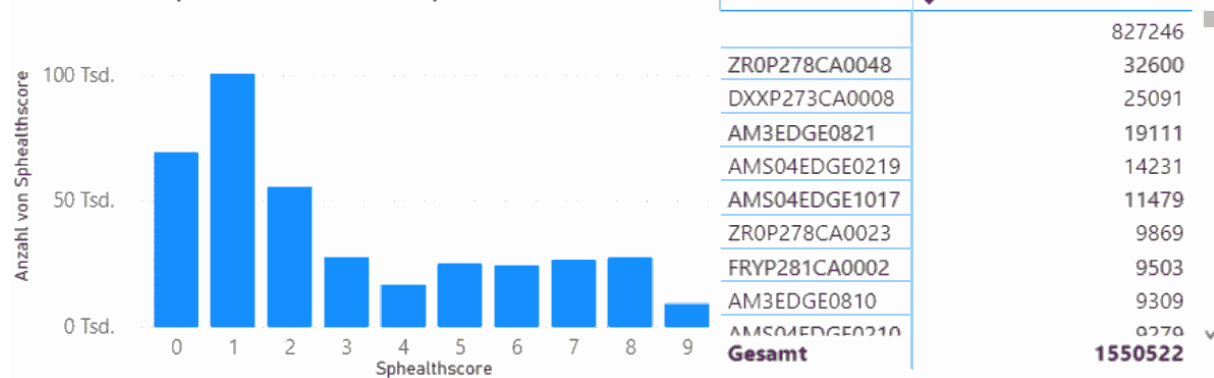

```
GET https://msxfaq.sharepoint.com/_layouts/15/SPAndroidAppManifest.aspx HTTP/1.1
User-Agent: Mozilla/5.0 (Windows NT; Windows NT 10.0; de-DE)
WindowsPowerShell/5.1.18362.145
Host: msxfaq.sharepoint.com
```

Find... (press Ctrl+Enter to highlight all) View in N

Transformer | Headers | TextView | SyntaxView | ImageView | HexView | WebView | Exchange Online

Office365 Auth | Auth | Caching | Cookies | Raw | JSON | XML

Response Headers [Raw] [Header Def]

HTTP/1.1 200 OK

Cache

Cookies / Login

Entity

Miscellaneous

MicrosoftSharePointTeamServices: 16.0.0.19520
MS-CV: nyKrwC5AAJC/RLp6XAYlcA.0
request-id: c0ab229f-402e-9000-bf44-ba7a5c062570
SPiisLatency: 1
SPRequestDuration: 112
SPRequestGuid: c0ab229f-402e-9000-bf44-ba7a5c062570
X-AspNet-Version: 4.0.30319
X-MS-Edge-Ref: Ref A: 187B1EDD2CCC487BB08FB6A7ED922BD5 Ref B: AM3EDGE0412 Ref C: 2019-12-18T10:30:32Z
X-MS-InvokeApp: 1; RequireReadOnly
X-Powered-By: ASP.NET
X-SharePointHealthScore: 7

Security



Sample: End2End-UDP3478

- Connect to UDP-port 3478
- Collect Endpoint name
- Measure Latency
- Measure Hop-Count

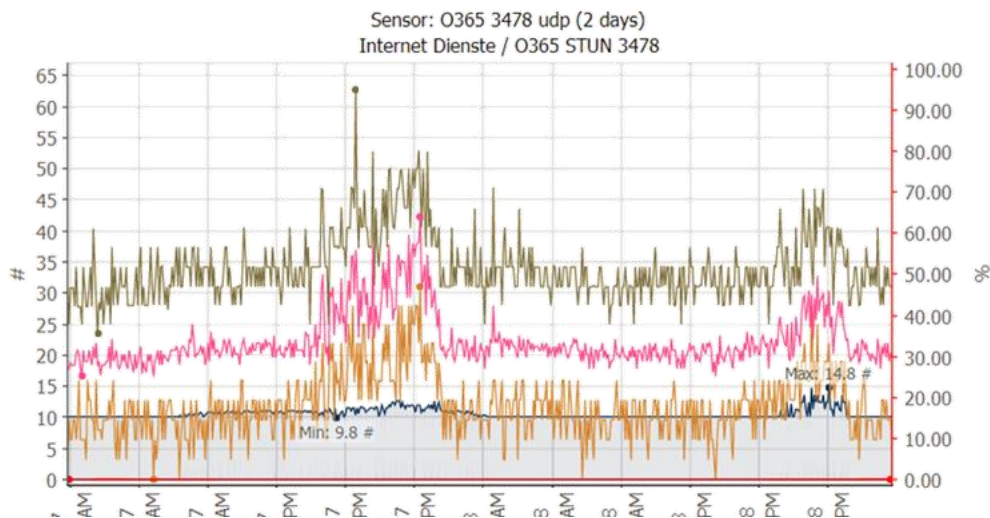

Auswählen End2End-UDP3478

```

PS C:\End2End> .\end2end-udp3478.ps1
End2End-UDP3467:Start
Mode           : END2END. continuous latency check and no distance check
MaxTTL         : 128
MaxRetries     : 0
AvgIntervalSec : 60
InterpacketsleepMS : 20
Sleeptime      : 0
prtgpushurl    :
TURN-Server    : Use Office 365 Microsoft Teams Server: IP=52.113.193.5
End2End-UDP3478:Start UDP-Client on 50019
End2End-UDP3478:Connect UDPClient to 52.113.193.5:3478
Colorcode:<=100ms<=200ms>200ms
Legend: 100 pakets max: . = max<100ms W= max<200ms E=max>200ms
End2End-UDP3478:Keyboard: use X=End P=Pause
2020-10-14 00:10:16Z:RTT: ..... (Min/Avg/Max):013/016/039 Total/Fail:1218/000
2020-10-14 00:11:16Z:RTT: ..... (Min/Avg/Max):014/016/028 Total/Fail:1215/000
2020-10-14 00:12:16Z:RTT: ..... (Min/Avg/Max):013/016/048 Total/Fail:1169/000
2020-10-14 00:13:16Z:RTT: ..... (Min/Avg/Max):014/016/055 Total/Fail:1183/000
2020-10-14 00:14:16Z:RTT: ..... (Min/Avg/Max):014/016/041 Total/Fail:1184/000
2020-10-14 00:15:16Z:RTT: ..... (Min/Avg/Max):014/016/020 Total/Fail:1203/000
2020-10-14 00:16:16Z:RTT: ..... E(Min/Avg/Max):013/016/037 Total/Fail:1186/001
2020-10-14 00:17:16Z:RTT: ..... (Min/Avg/Max):013/016/049 Total/Fail:1182/000
2020-10-14 00:18:16Z:RTT: ..... (Min/Avg/Max):014/016/020 Total/Fail:1211/000
2020-10-14 00:19:16Z:RTT: ..... (Min/Avg/Max):013/016/019 Total/Fail:1188/000
2020-10-14 00:20:17Z:RTT: ..... (Min/Avg/Max):013/016/019 Total/Fail:1205/000
2020-10-14 00:21:17Z:RTT: ..... (Min/Avg/Max):014/016/019 Total/Fail:1202/000
2020-10-14 00:22:17Z:RTT: ..... (Min/Avg/Max):013/016/033 Total/Fail:1196/000
2020-10-14 00:23:17Z:RTT: ..... (Min/Avg/Max):014/016/020 Total/Fail:1192/000
2020-10-14 00:24:17Z:RTT: ..... (Min/Avg/Max):014/016/019 Total/Fail:1189/000
2020-10-14 00:25:17Z:RTT: ..... (Min/Avg/Max):013/016/023 Total/Fail:1179/000
2020-10-14 00:26:17Z:RTT: ..... (Min/Avg/Max):014/016/026 Total/Fail:1169/000
2020-10-14 00:27:17Z:RTT: ..... (Min/Avg/Max):013/016/028 Total/Fail:1206/000
2020-10-14 00:28:17Z:RTT: ..... E..... (Min/Avg/Max):013/017/047 Total/Fail:1179/001
2020-10-14 00:29:17Z:RTT: ..... E..... (Min/Avg/Max):014/017/054 Total/Fail:1162/001
2020-10-14 00:30:17Z:RTT: ..... (Min/Avg/Max):013/017/045 Total/Fail:1179/000
2020-10-14 00:31:17Z:RTT: ..... (Min/Avg/Max):014/017/049 Total/Fail:1181/000

```





Missing: Connection advisor on every client

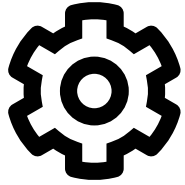

Configuration

- LAN/WLAN, Network boards, Default Gateway, Routing
- DNS-Server, Proxy-Server
- Operating System, Patchlevel, „Teams-Version“, ...

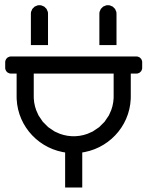

Connectivity

- Are all Services „reachable“ ? (ICMP, DNS, UDP, TCP, HTTP)
- Especially Microsoft 365 services (Exchange, SharePoint, Teams, ...)
- Other Cloud Services (Yes, they are also in use)
- Own services like VPN-Servers, Terminal Services gateways, ...



Durability

- Bandbreite vs. Latenzzeit, Packetloss, Jitter, Throughput
- Whats visible for the end user
- How reliable is that connection

Tools

- PowerShell End2End-Scripts
- Network tools (Cisco IP-SLA, HP-NQA, UDP-Mirrors, PRTG)
- On every Desktop
 - Configuration Check
 - Connection Check
 - Stability Check

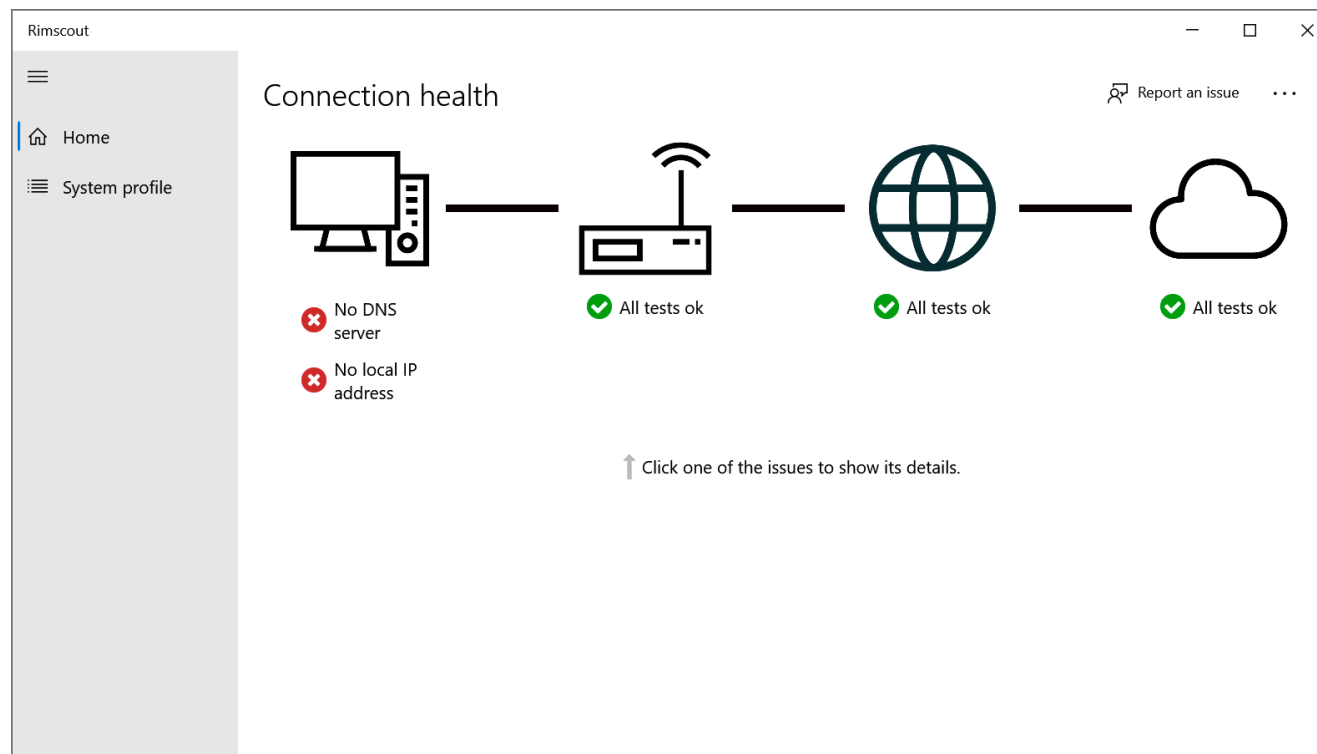



Rimscout: Sample Reports

- Continuous monitoring
- Compare client, location tc.

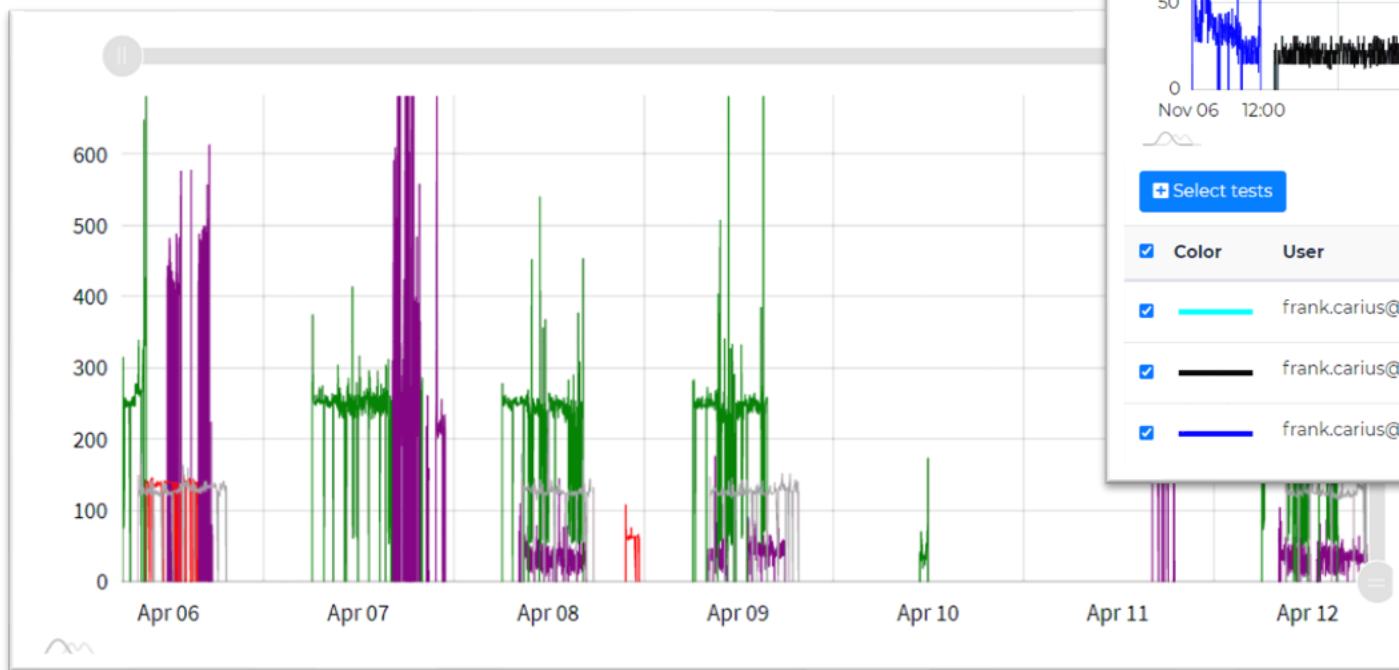



thank you



questions?



TWITTER HANDLE



BLOG URL



**1. GET
THE APP**



**2. VISIT SESSIONS
AND SPONSORS,
RATE THE SESSIONS**



**3. EARN
COLLABCOINS**



**4. SPEND COLLABCOINS
ON SWAG AND
VOUCHERS**

**5. TOP 5 WIN A
RASPBERRY PI 400**



csmmt.eu/app

