

Unified Communication mit Phone System (CloudPBX) und Teams



**Seit November 2017 ist Office 365 Telefonie
auch in Deutschland verfügbar.**

**Was geht heute schon, welche Optionen sind
verfügbar. Was steht auf der Roadmap**

Kurzvorstellung

- Net at Work
 - Standort Paderborn
 - Gegründet 1995
 - 70+ Mitarbeiter
 - IT-Systemintegration und Software Development
- Schwerpunkte
 - UC: Exchange, Skype for Business, Teams
 - SharePoint, Office 365
 - Infrastruktur: AD, ADFS, DirSync, Netzwerk
 - Security: Mail Encryption und Signierung, NoSpamProxy
- Frank Carius
 - Microsoft MVP für Skype for Business
 - Microsoft Certified Master Lync 2010
 - Betreiber von www.msxfaq.de



Master



Skype for Business History

- LCS
- OCS
- LYNC
- Skype for Business
- Teams



Microsoft Server mit VoIP

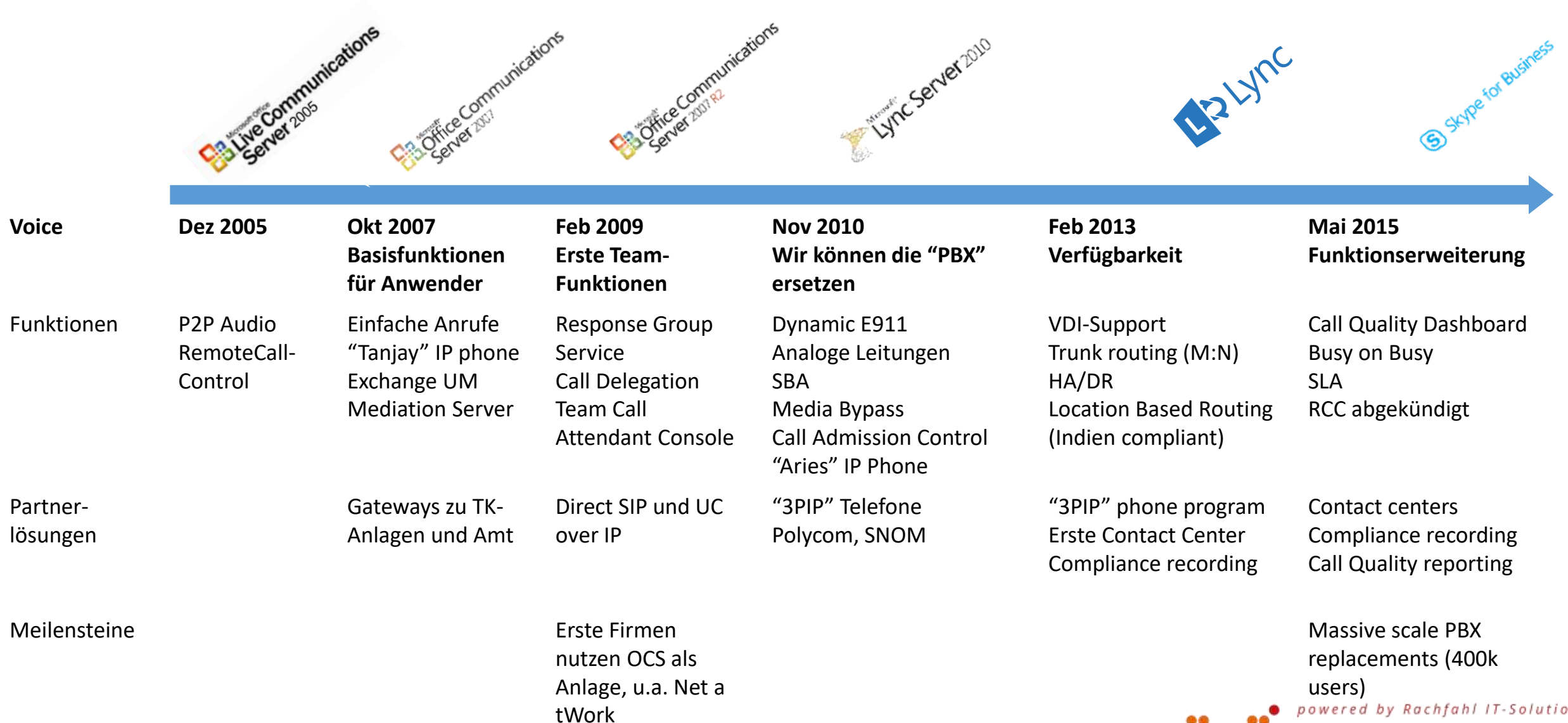

Skype for Business aus Anwendersicht



Präsenz/IM

- Sichtbarkeit Intern/Extern
- Kontaktkarte / Visitenkarte
- Federation
- Ethical Wall



Konferenz

- P2P oder Multi-Party, Belastung in Konferenzminuten
- Konferenzräume, Skype Room System, Surface Hub
- Extern Teilnehmer, Federation
- Konferenzwahl, TK-Anbindung



Telefon

- Gateway, SBC, Trunk, TK-Koexistenz
- Endgeräte: Telefon, PC, Tablet, Fax, Analog
- Chef/Sek, Call Verteilung, Busy
- Mobilteile, DECT, WiFi



Featureliste: Telefonie

- Anrufe annehmen und tätigen (über Nummer oder Name)
- Halten und Fortsetzen
- Anrufprotokoll, verpasste Anrufe
- Anrufe delegieren und im Auftrag anrufen
- Durchstellen, Bildtransfer
- Warten / Parken
- Anrufernummer anzeigen
- Anklopfen
- Rufumleitung und parallele Anrufe
- Clients für Windows, Mac, Mobil
- Wechsel des Headset/Handset
- Unterschiedliche Klingeltöne
- Anrufsperre (DND)
- Rufumleitung anhand des Outlook Kalenders
- Wartemusik
- Wähltastatur
- Federation mit Skype
- Federation mit Skype for Business
- Voicemail
- Video



Skype for Business On-premises

- Langer steiniger Weg
- Erscheint komplex
- Beschränkter Funktionsumfang
- Viele Drittprodukte erforderlich
- Keine richtige TK-Anlage
- Windows ist generell schlecht
- Viel zu teuer



Skype for Business OnPremise

- Grundbaustein
 - IM/Presence
 - P2P Audio im LAN

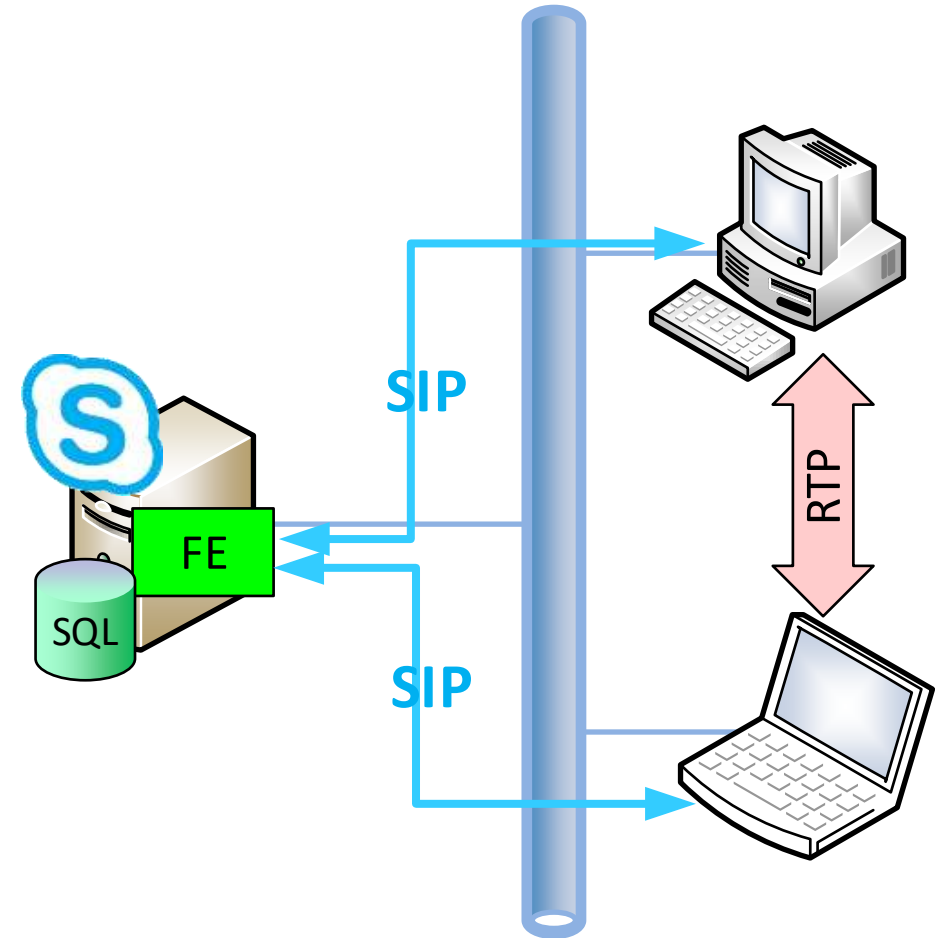

Skype for Business OnPremise

- Grundbaustein
 - IM/Presence
 - P2P Audio mit PCs
- Konferenz
 - MCU Audio/Video
 - Telefoneinwahl
 - Externer Zugriff
 - Externe Konferenzteilnehmer

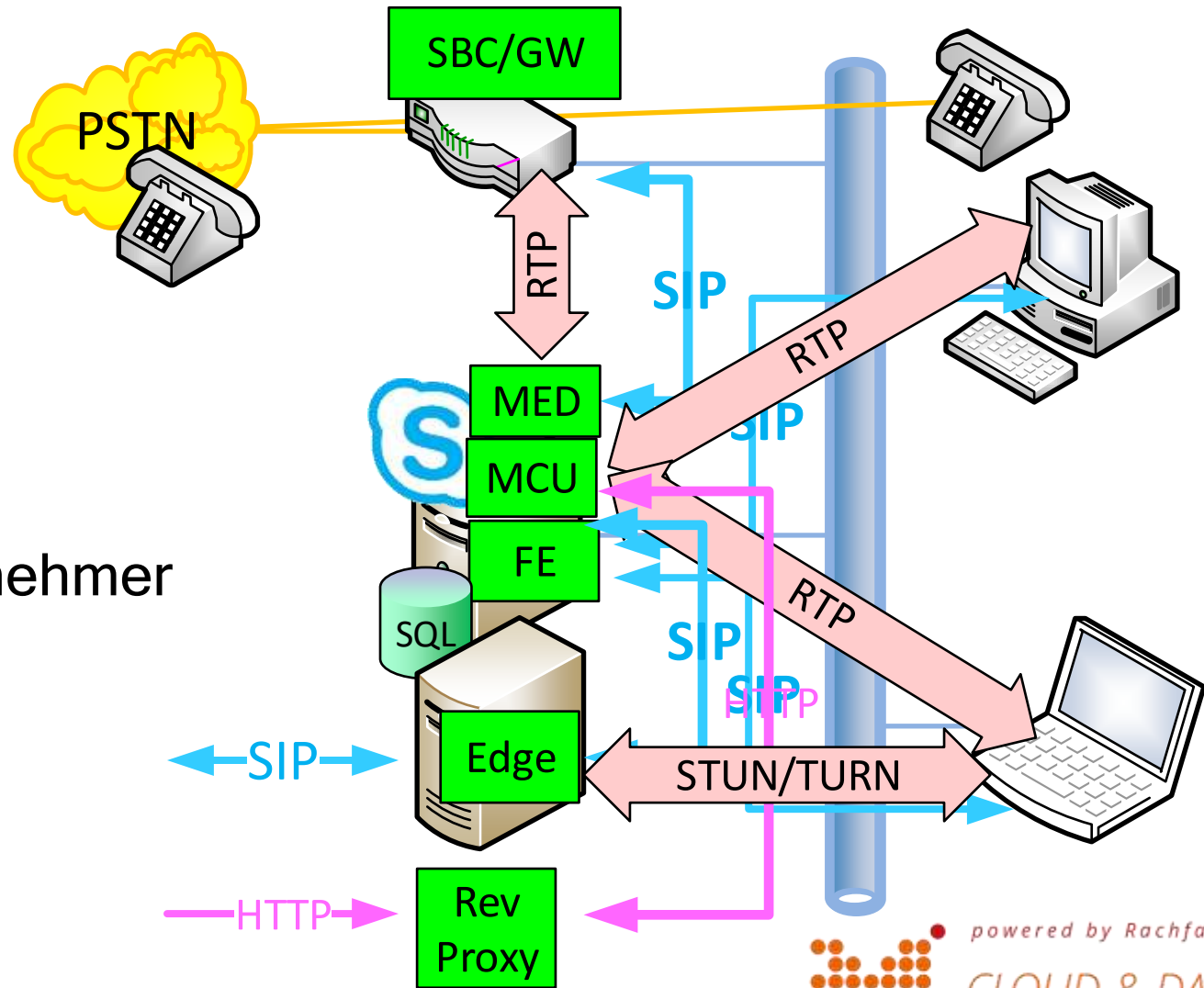

Skype for Business OnPremise

- Grundbaustein
 - IM/Presence
 - P2P Audio mit PCs
- Konferenz
 - MCU Audio/Video
 - Telefoneinwahl
 - Externer Zugriff
 - Externe Konferenzteilnehmer
- Telefonie
 - Telefonie User
 - Exchange UM
 - QoS/QoE/CDR

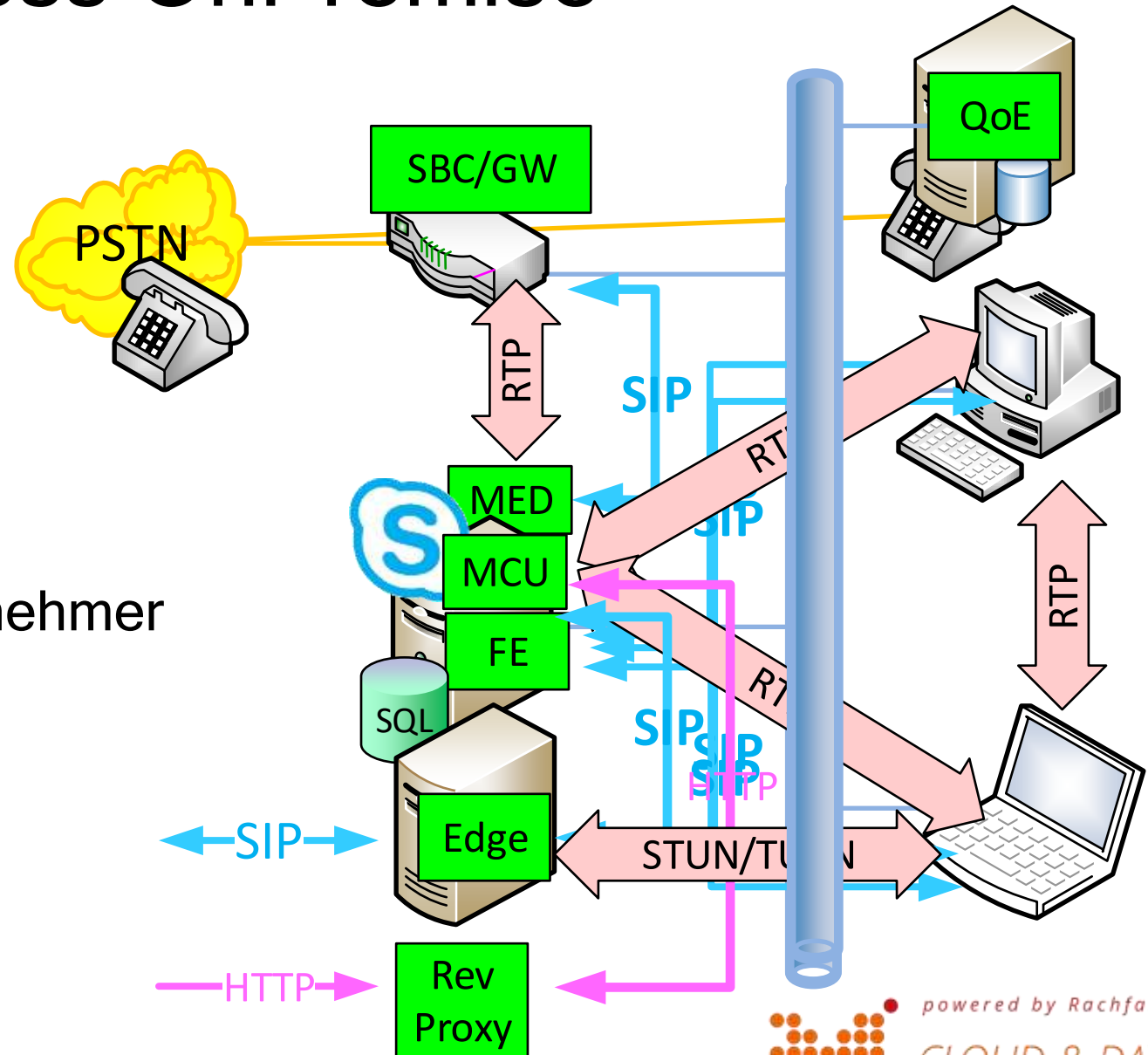

Verfügbarkeit

- Single Standard Pool
 - Eigenständige Systeme ohne HA
 - Kleine Umgebung
- Virtualisierung-HA
 - Hardwareunabhängigkeit
 - Hyper-V Replication
 - Geplante Downtime
 - Unterbrechung bei Fehler
- Pool Pairing
 - Failover für Basisfunktionen
 - Switchover manuell
 - Site Resiliency

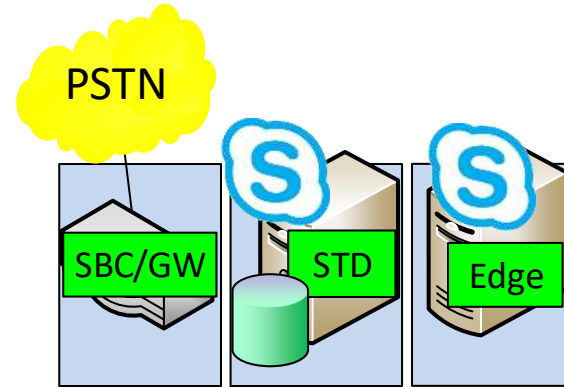

	Patchen	HW Fail	RZ Fail
IM	●	●	●
Konf	●	●	●
Tel	●	●	●

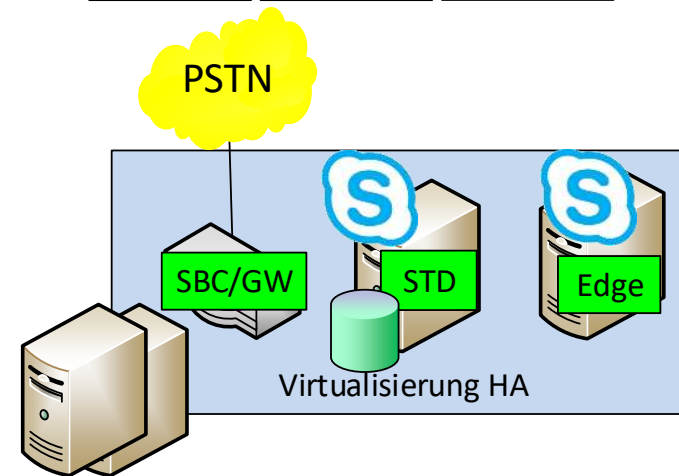

	Patchen	HW Fail	RZ Fail
IM	●	●	●
Konf	●	●	●
Tel	●	●	●

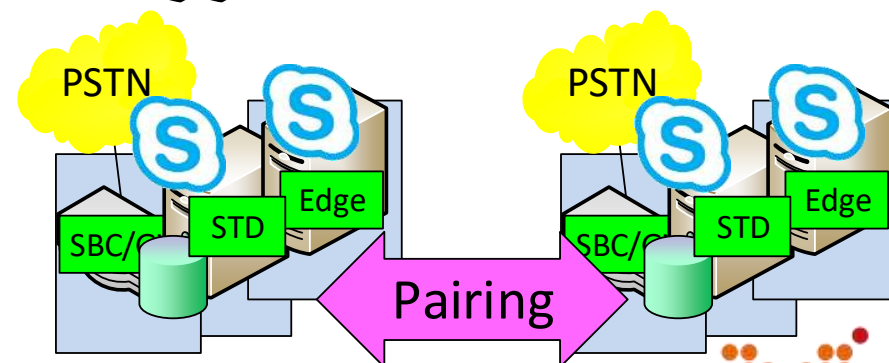

	Patchen	HW Fail	RZ Fail
IM	●*	●	●
Konf	●*	●	●
Tel	●*	●	●



zzgl. Loadbalancer, Office Web Apps, Exchange-UM, Reverse Proxy

Verfügbarkeit

- Frontend Pool
 - Scale-Out (bis zu 80.000 User)
 - Hohe Verfügbarkeit
 - SQL-Cluster + Lizenz
- FE Pool + Pool Pairing
 - zzgl. Site Resiliency
- SBA
 - Notbetrieb für Telefonie

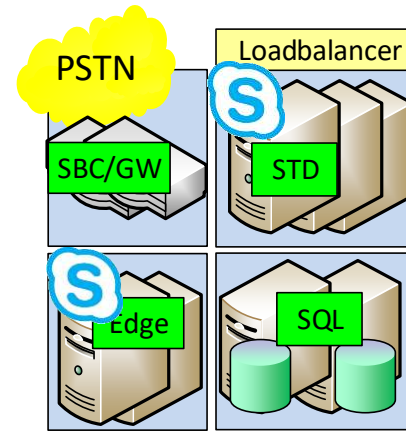

	Patchen	HW Fail	RZ Fail
IM	●	●	●
Konf	●	●	●
Tel	●	●	●

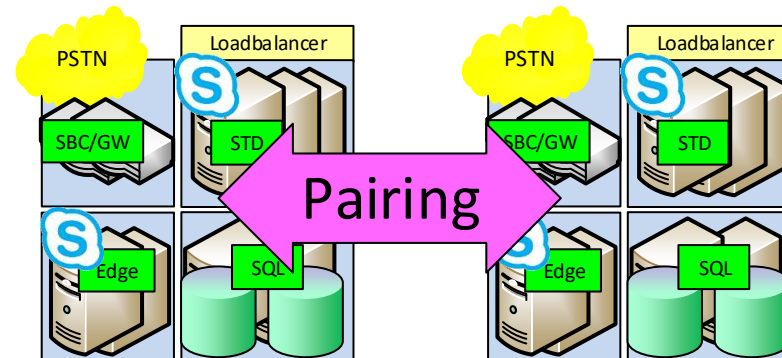

	Patchen	HW Fail	RZ Fail
IM	●	●	●
Konf	●	●	●
Tel	●	●	●

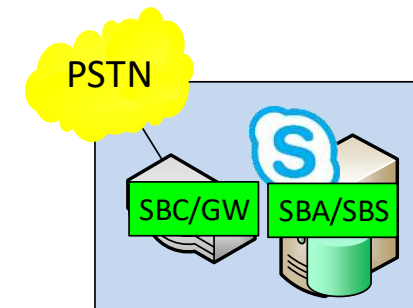

	Patchen	HW Fail	RZ Fail
IM	●	○	○
Konf	○	○	○
Tel	●	○	○



zzgl. Loadbalancer, Office Web Apps, Exchange-UM, Reverse Proxy

SIP und Telefonie

- Signalisierung
 - SIP-Adresse (frank.carius@netatwork.de)
 - Telefonnummer +49(5251)304613
 - SIP vs. ISDN
- Medien
 - Codec
 - Video Auflösung
 - Erforderlich Bandbreite
- Netzwerk
 - Firewall
 - STUN/TURN/NAT
 - QoS, CAC

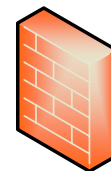
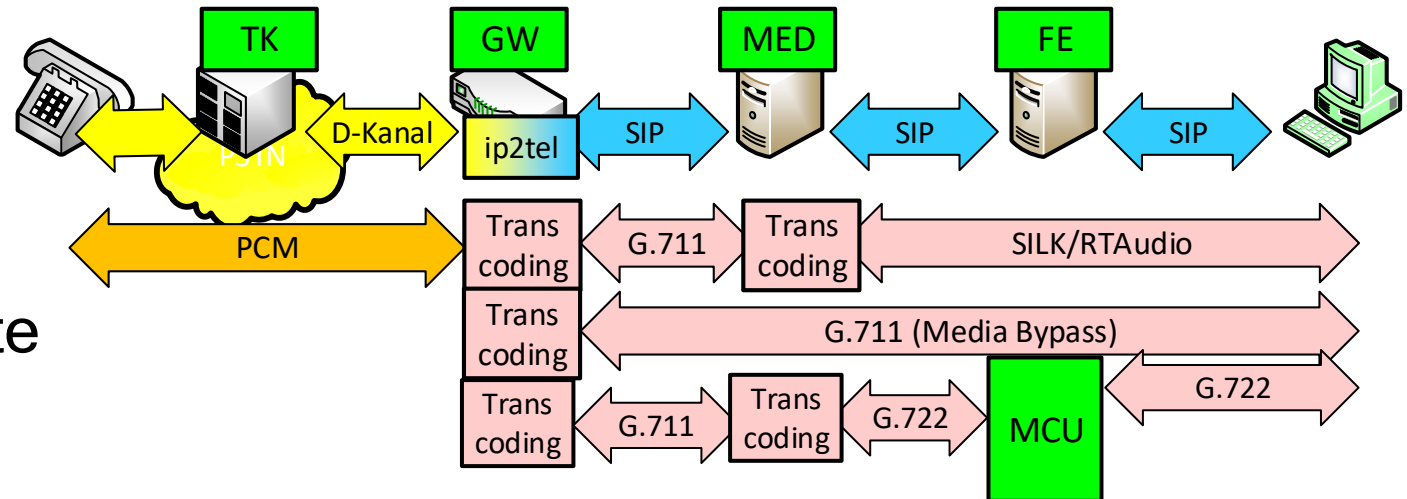

- HighPort
- 3478/UDP
- 443/TCP
- Proxy-Server

Office 365 „Phone System“



Skype for Business Online

- Voraussetzungen
 - Office 365 Tenant
 - SfB Plan 1 oder 2 in E3/E5 enthalten
 - Internetzugriff
 - SfB Client
- Out of the Box
 - IM/Presence
 - P2P Audio
 - A/V VoIP Konferenz
- AddOns Telefonie
 - Telefonanlage
 - Gebührenpakete
 - Konferenzwahl

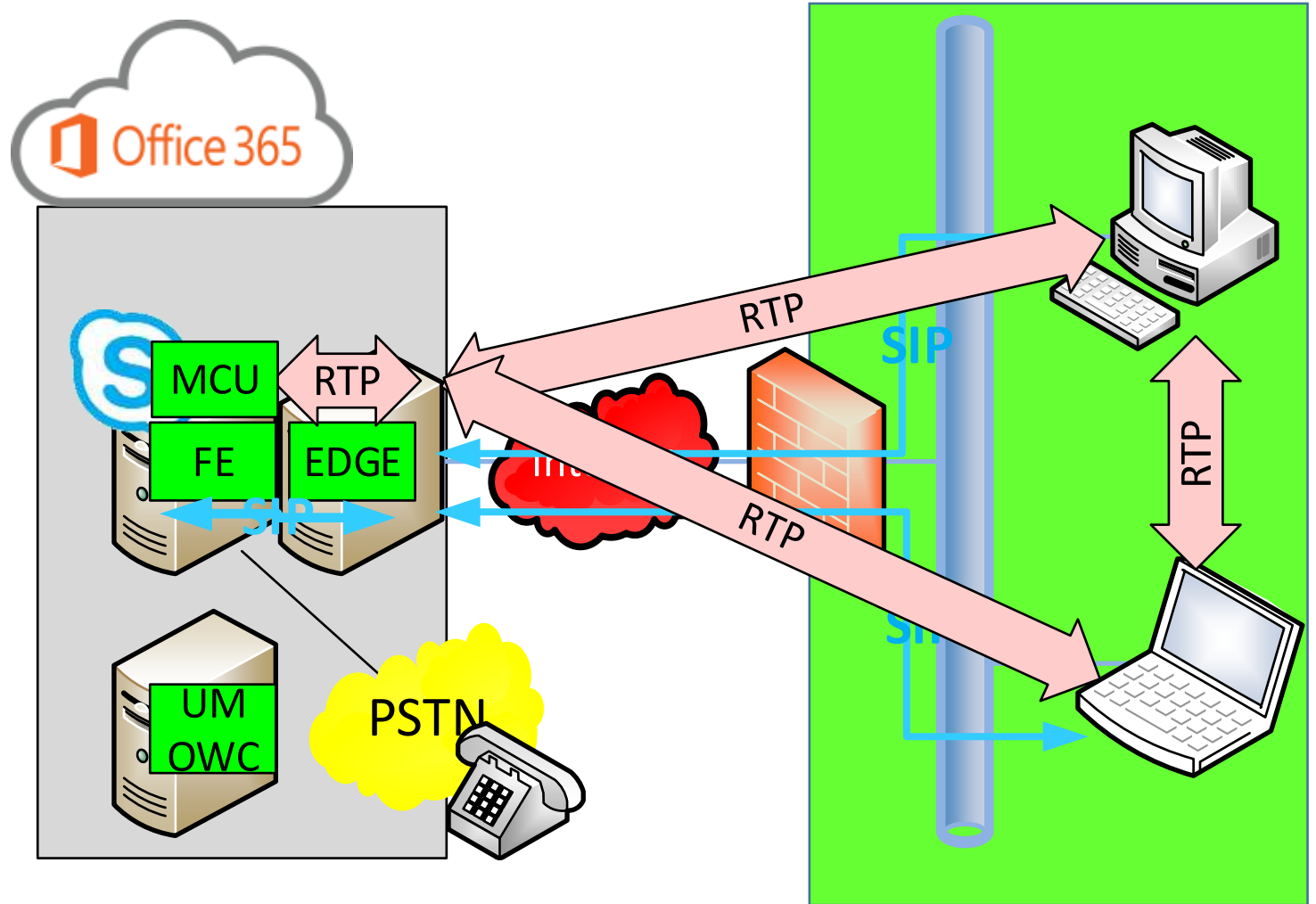

Skype for Business Online Telefonie

- Verfügbarkeit
 - 86 Länder Audio Konferenz Dialin
 - 63 Einwahlländer
 - 44 Dialout Länder
 - Aus 197 Ländern erreichbar
 - In 11 Ländern mit PSTN Calling
 - Deutschland seit November 2017
 - Rufnummern in deutschen Ortnetzen
- VoiceMail
 - Aufzeichnung landet im Postfach (OnPrem/Cloud)
Aufzeichnung als Anlage
 - Transcription (noch nicht für Deutsch)
- Alle Dienste aus der Cloud
 - Keine lokale TK-Anlage
 - Keinen lokalen Amts-Anschluss
 - Rufnummern von Microsoft
 - Gebührenabrechnung über Office 365
- Erforderlich
 - Office 365 Tenant + Lizenzen
 - Geeignete Clients
 - Netzwerkverbindung
- Konferenzeinwahl
 - Telefonie-Teilnehmer

Country and region availability for Audio Conferencing and Calling Plans

<https://docs.microsoft.com/de-de/SkypeForBusiness/country-and-region-availability-for-audio-conferencing-and-calling-plans/country-and-region-availability-for-audio-conferencing-and-calling-plans>

<https://docs.microsoft.com/de-de/SkypeForBusiness/country-and-region-availability-for-audio-conferencing-and-calling-plans/availability-in-germany>

Skype for Business Online Lizenzen

Office 365 Lizenz	ProPlus	E1 6,70€	E3 19,70€	E5 34,40€
Office 365 Professional Plus auf 5 PCs, 5 Smart-Devices	✓	✗ Nein	✓	✓
OneDrive	1TB	1TB	1TB	1TB
Exchange Online Postfach	✗ Nein	50GB	∞	∞
Skype for Business Online CAL	✗ Nein	✓	✓	✓
Skype for Business Windows Client	✓	✗ Basic	✓	✓
Meeting Broadcast	✗ Nein	✓	✓	✓
Audio Conference (Einwahl) 3,40€ , DialOut nach Preisliste	✗ Nein	✗ +	✗ +	✓
Phone System (6,70€)	✗ Nein	✗ +	✗ +	✓
Calling Plan (10,10€ oder 20,24€)	✗ Nein	✗ + x	✗ + x	✗ + x
Data Loss Prevention, Encryption	✗ Nein	✗ Nein	✓	✓
PowerBI Pro, Delve Analytics, Equivio eDiscovery, Secure Attachment and URLs, ...	✗ Nein	✗ Nein	✗ Nein	✓

Skype for Business-Add-On-Lizenzierung <https://support.office.com/de-de/article/Skype-for-Business-Add-On-Lizenzierung-3ed752b1-5983-4310-bcfd-760619ab40a7>

Lizenz/Kosten

- Phone System

- Lizenz zur Nutzung von „Rufnummern“
- TK-Link nicht enthalten (CCE/Hybrid)
- E1/E3: 6,70 €/Monat/User
- In E5 enthalten
- <https://products.office.com/de-de/skype-for-business/phone-system>

- Calling Plan - Die „Gesprächsminuten“

- Pro User zu kaufen
- DE National (1200 Min) 10,10€
- DE International (600 Min) 20,24€
Inkl. 1200 Minuten National
- Minuten werden „gepoolt“

- Audio Konferenzeinwahl

- E1/E3: 3,40€/User/Monat (Dial-In)
- In E5 enthalten
- Dial-Out pro Minute
- <https://products.office.com/de-de/skype-for-business/audio-conferencing>
- <https://docs.microsoft.com/de-de/SkypeForBusiness/accessibility-and-regulatory/complimentary-dial-out-period>

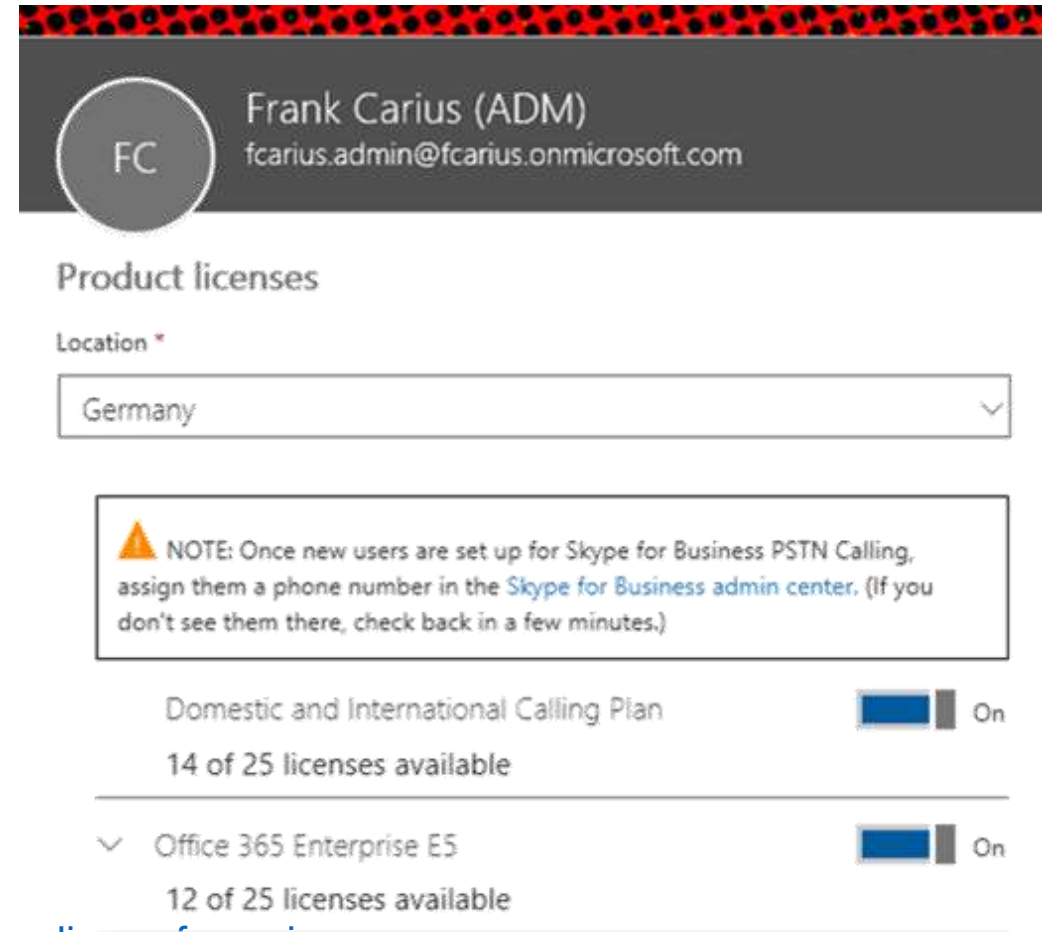

Frank Carius (ADM)
fcarius.admin@fcarius.onmicrosoft.com

Product licenses

Location *
Germany

NOTE: Once new users are set up for Skype for Business PSTN Calling, assign them a phone number in the [Skype for Business admin center](#). (If you don't see them there, check back in a few minutes.)

Domestic and International Calling Plan On
14 of 25 licenses available

Office 365 Enterprise E5 On
12 of 25 licenses available

[What are Communications Credits?](https://docs.microsoft.com/en-us/SkypeForBusiness/skype-for-business-and-microsoft-teams-add-on-licensing/what-are-communications-credits)

<https://docs.microsoft.com/en-us/SkypeForBusiness/skype-for-business-and-microsoft-teams-add-on-licensing/what-are-communications-credits>

Country and region availability for Audio Conferencing and Calling Plans

<https://docs.microsoft.com/en-us/SkypeForBusiness/country-and-region-availability-for-audio-conferencing-and-calling-plans/country-and-region-availability-for-audio-conferencing-and-calling-plans>

Andere Optionen für Telefonie-Links

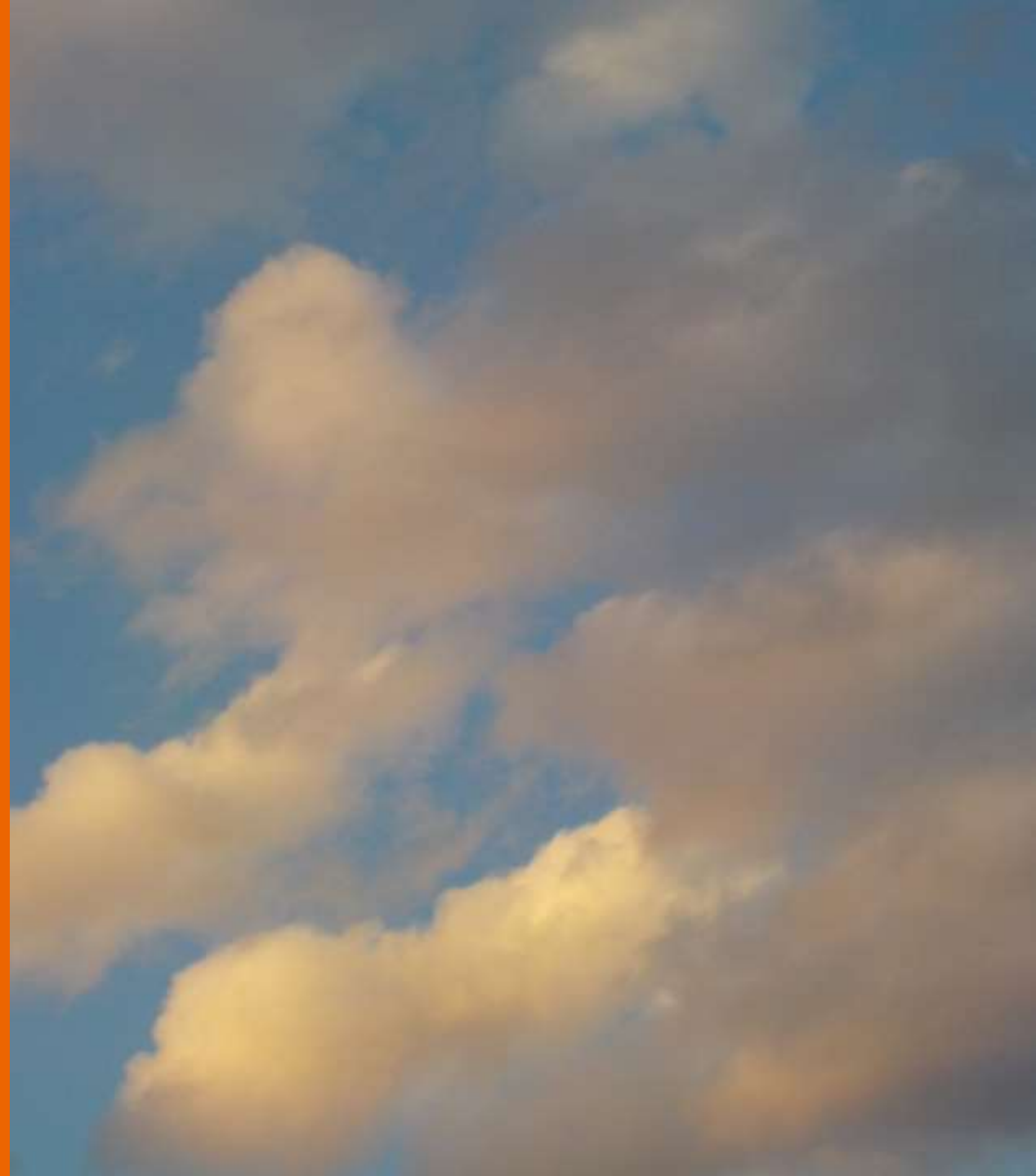

Skype for Business Online Telefonie



OnPremise

- Lokale Server
- Lokaler PSTN-Trunk
- Alles „self hosted“



CloudPSTN

- CloudPBX Service
- PSTN-Services by Microsoft

Seit Nov 2017
in DE



Hybrid

- Online und OnPremise
- Migration und Koexistenz
- Cloud Telefonie über lokalen Trunk



CCE

- CloudPBX Service
- OnPremise PSTN-Trunk
- Lokale BlackBox

nicht mit
Hybrid!



Teams

- Bring Your Own Trunk (BYOT)

bald



Cloud Connector Edition

- Kunde stellt
 - Serverhardware mit Hyper-V
 - Lizenz: Win 2012R2 Datacenter
 - Office 365 Tenant mit CloudPBX
- CCE Installation
 - PowerShell + INI-Datei
 - 4 VMs (DC, Store, Edge, Mediation)
 - Keine Koexistenz mit Hybrid
- Lokaler SIP-Trunk
 - Ggfls. Gateway oder SBC erforderlich
 - Max. 500 gleichzeitige Anrufe
 - Kleine Version mit 50 Calls
- ScaleOut / Hochverfügbarkeit
 - Mehrere CCE pro Standort
 - Mehrere SIP-Trunks pro CCE
 - CCE in verschiedenen geografische Regionen
- Box-Lösungen von Partnern
 - Audiocodes, Ribbon, Ferrari, TESystem, u.a.
 - ThinkTel (Hosting in Kanada)

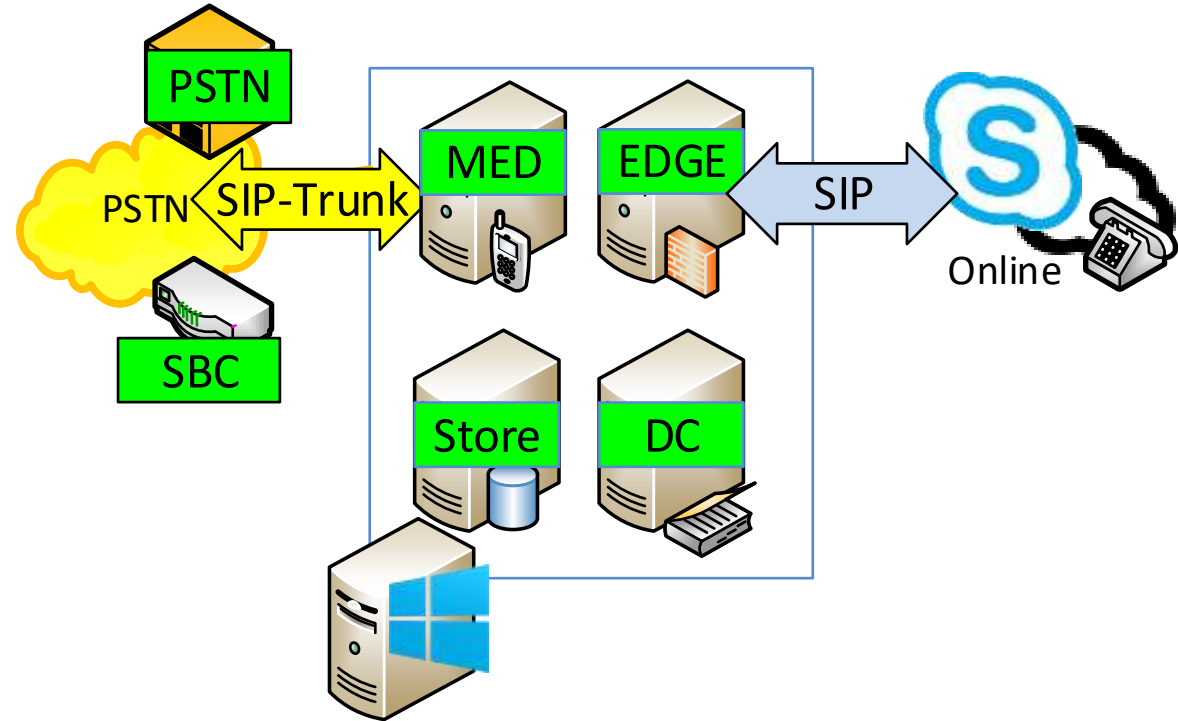

Direct Connection mit Microsoft Teams

- Nur für Teams
 - Nicht für Skype for Business Online
- SIP-Trunk
 - Verbindung: über Internet
 - Ziel: Office 365 SBCs
 - Geografisch verteilt
 - Quelle
 - Eigener lokaler SBC
 - Eigener PSTN-Anbieter

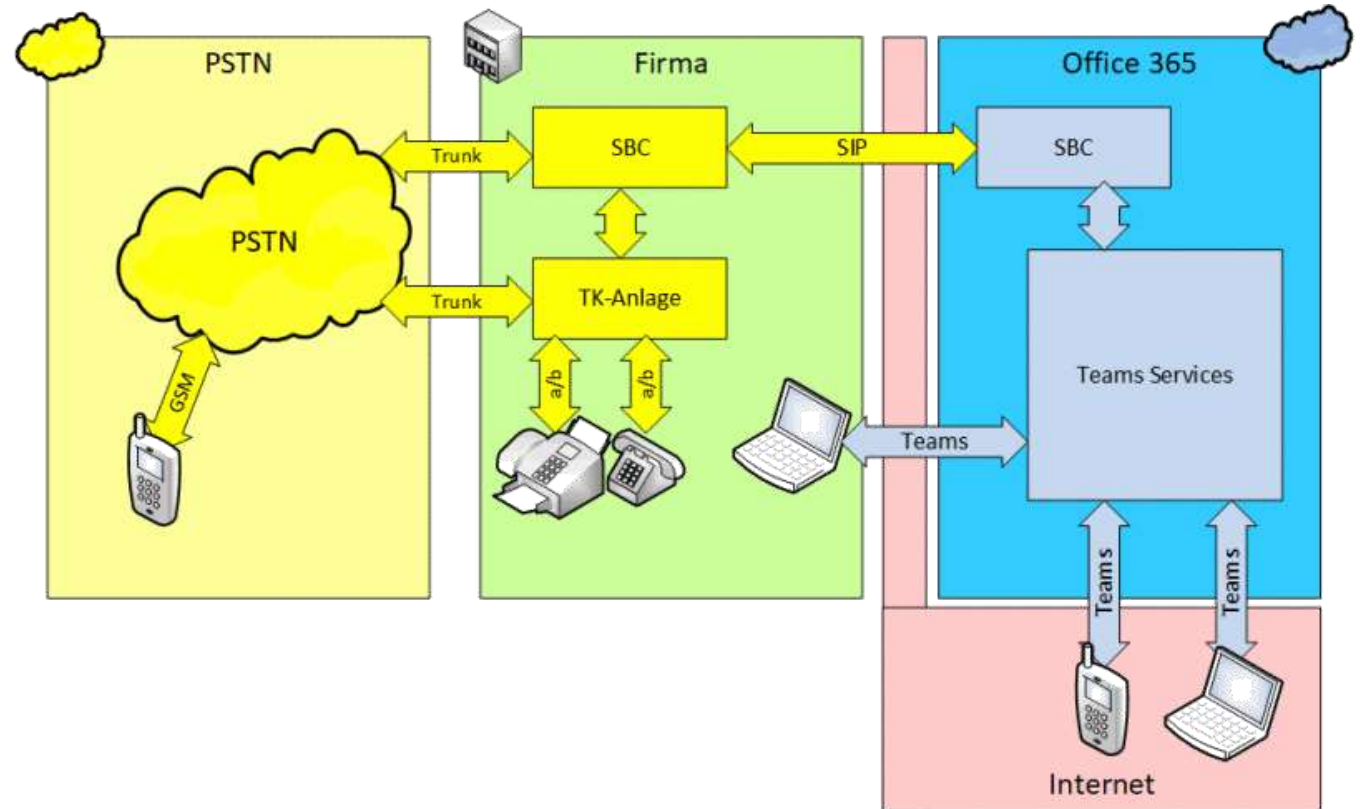

Endgeräte



Phone System Clients

- Skype for Business Desktop Client
 - Lizenz in E3/E5
 - Oder „Basic Client“
- Skype for Business Mobile Client
 - Kostenfrei über AppStore
- Telefone
 - Polycom
 - Audiocodes
 - Yealink
- Microsoft Teams Client
 - Windows
 - Mobil
 - Browser

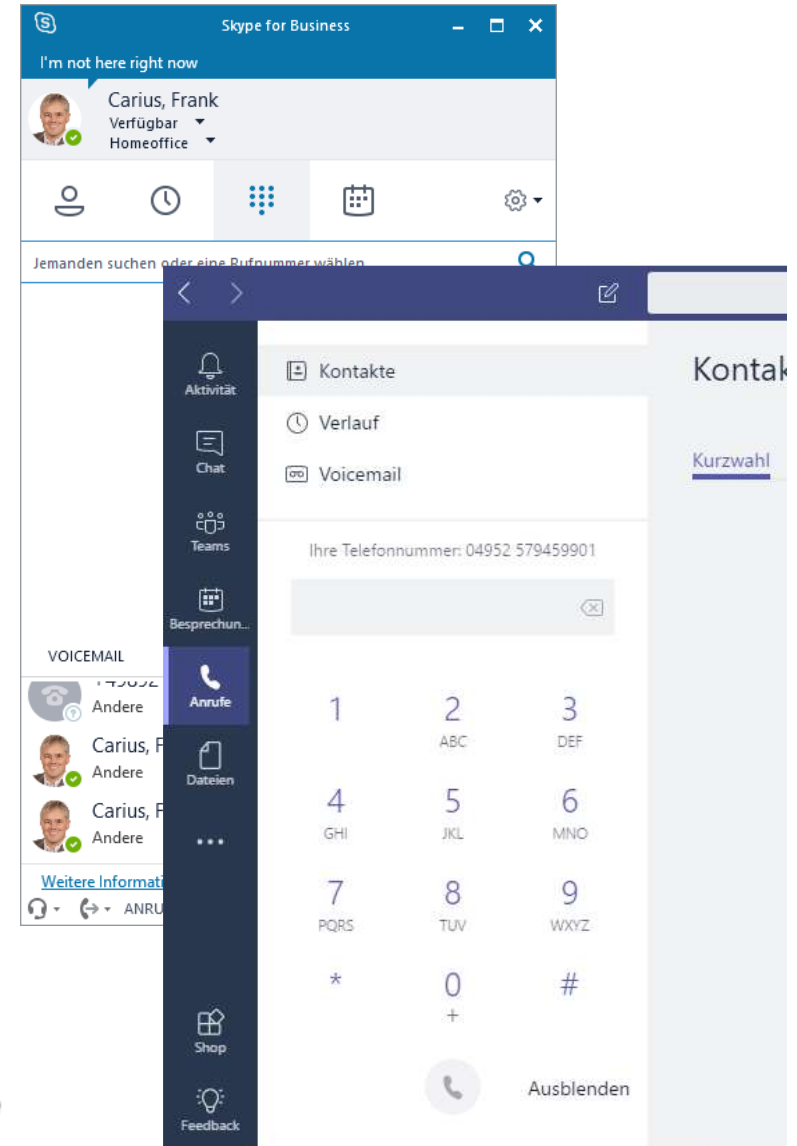

Endpunkte nach Lösung

	CloudPBX	CCE	Hybrid	On Prem Only	Teams Direct Connection
Windows PC	✓	✓	✓	✓	✓ TeamsOnly
Smartphone App	✓	✓	✓	✓	✓ Teams Only
3PIP Phone	✓ (FW Update)	✓	✓	✓	☑ mit FW Update
Analoge Telefone	☒ Nein	✓	✓	✓	✓ am lokalen SBC
DECT-Telefone	☒ Nein	✓ Ohne Präsenz	✓	✓	✓ am lokalen SBC
PBX Koexistenz	☒ Nein	Über Gateway	✓	✓	✓ Ja
UCMA	☒ Nein	☒ Nein	✓ (nur OnPrem)	✓	☒ Nein



by Rachfahl IT-Solutions

**CLOUD & DATACENTER
CONFERENCE Germany**

Sonderfunktionen TK

Funktion	On Premise	CloudPBX	Hybrid	Cloud Connector	Teams BYOT
Basisfunktionen	IM. Presence, Anruf über Nummer oder Name, Anzeige des Anrufers, Stummschalten, Weiterleiten, Makeln, Anklopfen, Anruferliste, MoH, u.a.				
Call Warteschlangen	Response Groups	Call Queues	Beides, nicht übergreifend	Call Queues	
Besetzzeichen (Busy)	Seit SfB CU3 (Jul 2016)	Noch nicht	Nur OnPremise	Noch nicht	Noch nicht
Call Parken	Ja	Nein	Nur OnPrem	Nein	
Sprachmailbox/ AA	Exchange UM	Azure Voicemail	Einschränkungen	Azure Voicemail	Azure Voicemail
Boss/Admin, Shared Line	Ja	Ja	Nicht übergreifend	Ja	Roadmap
Vermittlungsplatz	über 3rd Party				
Delegate Call / on Behalf	Ja	Ja	Nicht übergreifend	Ja	Roadmap
SfB Telefone	Ja	Ja (aktuelle Firmware)	Ja	Ja	Roadmap
Türstation, DECT u.a.	Über SBC/GW/3rd Party	Noch nicht	Über SBC/GW/3rd Party	Über SBC/GW	Über SBC/GW

Skype for Business Online Features <https://technet.microsoft.com/en-us/library/mt631190.aspx>

Netzwerk

- Jeder will an sein Ziel



Network Ready ?

- Signalisierung (SIP over http)
 - Port 443
 - 5-10 kbit/User/Sek
 - Unkritisch bezüglich Zeit
- RTP Anforderungen
 - Client zu Office 365
 - <https://aka.ms/sof-media-quality>
 - Audio: 100kbit/Sek
- Protokoll: UDP bevorzugt
 - TCP oder https ist schlecht
 - Port 50.000-50059
 - Port 3478-3481
- Network Assessment
 - https://www.msxfaq.de/skype_for_business/tools/microsoft/skype_for_business_online_network_assessment_tool.htm

Wert	Client zu Edge
Packet loss rate	<10% in einem 200ms Intervall <1% innerhalb eines 15s Intervall
RTT Latency	<100ms
Jitter	<30ms innerhalb 15s Intervall
Packet reorder	<0,05%

Netzwerküberlegungen

- „Optimaler Weg“ zum Microsoft Global Network
 - Kurze Wege, wenig Hops
 - Proxy Bypass
 - Lokaler Breakout
- Internet als Transportweg
 - Frage der Verfügbarkeit
 - Kein QoS, Kein CAC
 - Option ExpressRoute
- Tests und Monitoring
 - Vorprojekt: Network Assessment
 - Personas und Bandbreitensimulation
 - Betrieb: SfB Online Reporting

'Daily' Graph (5 Minute Average)

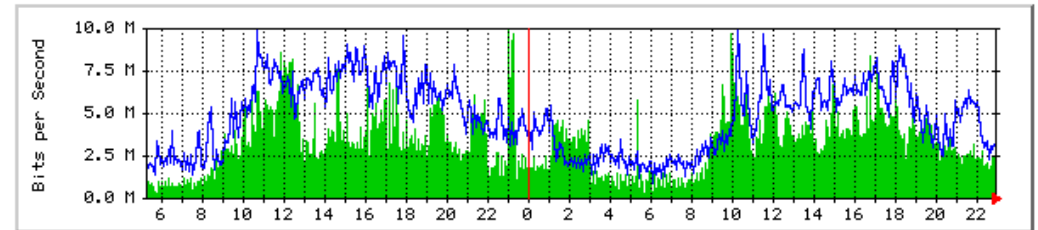

Max In: 9938.0 kb/s (9.9%) Average In: 3403.8 kb/s (3.4%) Current In: 1900.5 kb/s (1.9%)
Max Out: 9946.0 kb/s (9.9%) Average Out: 4820.8 kb/s (4.8%) Current Out: 3306.9 kb/s (3.3%)

'Weekly' Graph (3

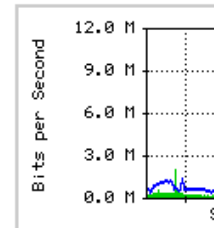

Max In: 11.4 Mb/s (11.4%)
Max Out: 8678.4 kb/s (8.7%)

```
D:\nawcd\Microsoft\Lync\AddOns\Skype for Business Online Network Asses
Skype for Business - Network Assessment Tool
Initializing audio call.
Remote IP address: 13.107.8.20
Audio file used: Tone.wma
Audio call duration: 17 s
Received audio file: ReceivedAudioFile.wma
Num iterations: 1
Call interval: 5 s
Results File: results.tsv
*****
Starting new call
Iteration 1 / 1
Audio call started. Waiting for call to end...
Call should end shortly after configured duration of 17 s.
```



CloudPBX und Datenverkehr

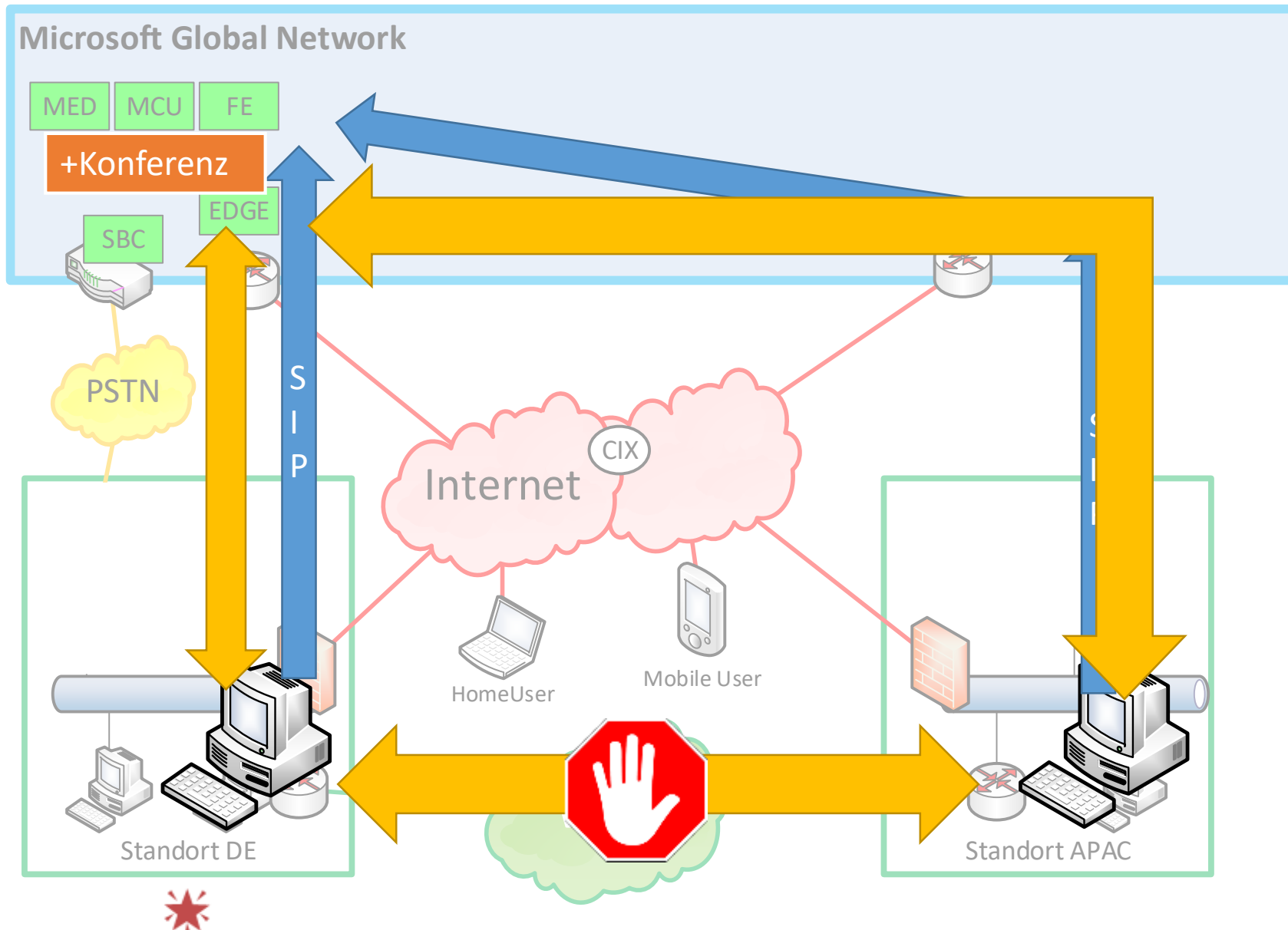

- Wenige Hops
 - lokale Breakouts
 - Wenig Peering
- Offen für
 - 443/TCP
 - 3478/UDP
 - HTTPProxy
 - Reject / Drop
- Optimiertes WAN

Rufnummern und Policies



Rufnummern

- Nummern beantragen
 - US, F, UK: Online einfach anfordern
 - DE: „PDF-Formular ausfüllen
- Rufnummernblöcke
 - Immer vielfache von 10 oder 100
 - Blockgröße nach Anzahl Lizenzen
 - $(10+\text{CALs})^* 1,1$
 - Spätere Nachanforderungen nicht zwingend zusammenhängend
- Unterscheidung
 - Nummern für Personen (normale Anrufzahlen)
 - Servicenummern (Call Queues, AutoAttendant)
- Portierung von Nummern
 - Abhängig vom abgebenden Inhaber
 - In der Regel keine Teilblöcke oder Einzelnummern in DE

Lizenzen	Formel	Effektiv
10	22	30
50	66	70
100	121	200 (?)
1000	1210	1300 (?)

Rufnummern beantragen

- Notfallstandort anlegen
 - Damit Notrufe zugeordnet werden
- Rufnummer beantragen
 - Link siehe unten
- Zuweisung abwarten
- Nummer an Benutzer zuweisen

The image shows a screenshot of a Skype for Business email and the admin center. The email, from the EU Number Porting Team, confirms the successful completion of a phone number order. The admin center screenshot shows a table of available phone numbers, with one number (+49 5257 945904) selected and the 'Assign' button highlighted in a red box. A tooltip for the 'Assign' button explains that the number is active for two-way calling and provides information on how to change the emergency location or release the number.

Speichern Verwerfen

Skype for Business

Anforderung neuer Telefonnummern

Vielen Dank, dass Sie Skype for Business als Dienstanbieter ausgewählt haben. Dieses Formular muss ausgefüllt und an Skype for Business übermittelt werden, um neue Telefonnummern zu erwerben. Wir informieren Sie über den Fortschritt.

WICHTIG

RE: Phone Number Request fcarius.onmicrosoft.com - Nachr...

DATEI NACHRICHT ENTWICKLERTOOLS

Mo 24.07.2017 17:15

EU Number Porting Team <PTNEU@microsoft.com>

RE: Phone Number Request fcarius.onmicrosoft.com

An EU Number Porting Team; Carius, Frank

Hi,

Good news! Your number order completed successfully!

Skype for Business admin center

phone numbers port orders voice users emergency locations on premises PSTN

You have 16 licenses

	Number	Number Location	Assigned	Number Type	Number Status	
<input type="checkbox"/>	+49 5257 94590	Hövelhof, Germ	Unassigned	User	Activated	
<input checked="" type="checkbox"/>	+49 5257 94590	Hövelhof, Germ	Unassigned	User	Activated	+49 5257 9459904
<input type="checkbox"/>	+49 5257 94590	Hövelhof, Germ	Unassigned	User	Activated	Assign
<input type="checkbox"/>	+49 5257 94590	Hövelhof, Germ	Unassigned	User	Activated	The phone number selected is active for two-way calling.
<input type="checkbox"/>	+49 5257 94590	Hövelhof, Germ	Unassigned	User	Activated	Emergency location
<input type="checkbox"/>	+49 5257 94590	Hövelhof, Germ	Unassigned	User	Activated	Glockenblumenweg 9 Glockenblumenweg 9 Hövelhof 33161 DE
<input type="checkbox"/>	+1 832-856-474	Houston, United	Conference Brid	Service	Activated	To change the emergency address or release the number, you must submit a custom service request.
<input type="checkbox"/>	+33 3 69 24 89	Strasbourg, Fran	Call Queue	Service	Activated	How to submit a custom service request
<input type="checkbox"/>	+33 3 69 24 89	Strasbourg, Fran	Auto Attendant	Service	Activated	
<input type="checkbox"/>	+1 425-526-344	Seattle, United	User	User	Activated	
<input type="checkbox"/>	+1 425-526-344	Seattle, United	User	User	Activated	

<https://docs.microsoft.com/de-de/SkypeForBusiness/what-are-calling-plans-in-office-365/get-new-user-phone-numbers-request-forms>

Übersicht der Rufnummern

Office Admin center - Active voice users TN Planen Sie Ihr Telefonsystem

https://admin2a.online.lync.com/LSCP/Users.aspx

Skype for Business admin center

phone numbers port orders **voice users** emergency locations on premises PSTN

Active users Enabled

<input type="checkbox"/>	Display name	Number	Number Status	PSTN Connectivity
<input type="checkbox"/>	adm-fcarius	+49 5251 304774		On-premises
<input type="checkbox"/>	Christian Löhr			Online
<input type="checkbox"/>	CloudDE 3			Online
<input type="checkbox"/>	CloudUS1			Online
<input type="checkbox"/>	CloudUS2			Online
<input type="checkbox"/>	Demo1 Cebit	+1 425-526-3442	Activated	Online
<input type="checkbox"/>	EV Testuser Fr	+33 1 73 01 07 50	Failed	Online
<input type="checkbox"/>	Frank Carius (ADM)	+49 5257 9459901	Activated	Online
<input type="checkbox"/>	Schubert, Michael (ADM)			Online
<input type="checkbox"/>	Stefan Junghahn (ADM UCLABOR)	+49 5251 304797		On-premises
<input type="checkbox"/>	Tuttass, Christian (ADM)			Online
<input type="checkbox"/>	Wulhorst, Dirk (ADM)			Online
<input type="checkbox"/>	Zweers, Marco ADM	+1 425-526-3644	Activated	Online

50

Nummernportierung

- SelfService
- Achtung Accountinfo muss „genau“ stimmen

The screenshot displays the Skype for Business admin center interface. At the top right, there is a user profile for 'Frank Carlus (ADM)'. The main navigation menu on the left includes 'voice', which is currently selected. The main content area is titled 'How to transfer your phone numbers to Skype for Business' and shows a progress list with '2. account info' highlighted. The form for 'New Local Number Port Order' includes several input fields with asterisks indicating required information: 'Account number (max. 20 alphanumeric characters only)', 'Billing telephone number (E.164 format)', 'PIN to unblock numbers', 'Your company name (max. 25 characters)', and 'Authorizing person (max. 15 characters)'. There is also a section for 'Service address' with fields for 'Number' and 'Driver Name', and an 'Address line 2' field. A vertical grey bar on the right side of the form contains the text 'your way. the'.

Dialplan

- Umsetzen der gewählten Nummer auf eine E.164 Nummer
- Standard-Einstellungen je Land
- Eigene Regeln für
 - ... gleiches Ortsnetz
 - ... interne Nummern
- Zuweisen
- Testen

```
PS C:\> (Get-CsDialPlan -Identity "Tag:DE").normalizationrules
Description      : DE International Dialing Rule
Pattern          : ^00(\d+)$
Translation      : +$1
Name             : DE Intl Dialing
IsInternalExtension : False
```

```
New-CsTenantDialPlan `
-Identity "UCLabor495251304" `
-Description "DialPlan UCLabor" `
-ExternalAccessPrefix 0 `
-SimpleName "UCLabor495251304"

$Rule1 = New-CsVoiceNormalizationRule `
-Identity Global/UCLabor495251304 `
-Description "DE Paderborn Intern" `
-Pattern '(0(\d{3})$)' -Translation '+495251304$1' `
```

```
Grant-CsTenantDialPlan `
-Identity user1@uclabor.de `
-PolicyName Tag:UCLabor495251304 `
```

```
Get-CsEffectiveTenantDialPlan `
-Identity user1@uclabor.de `
| Test-CsEffectiveTenantDialPlan `
-DialedNumber 12345

RunspaceId : 0a206064-279a-4cef-a2c3-92d45cf210dc
TranslatedNumber : +49525112345
MatchingRule : Description=DE Paderborn
Local;Pattern=^(\d{2}\d+)$;Translation=+495251$1;Name=UCLabor495251;IsInternalExtension=False
```

Call Queues

- Bis zu 50 Agenten und 200 Anrufe
- Individuelle Ansage mit Wartemusik
- Anrufverteilung
 - Parallel: Alle Agenten klingeln
 - Seriell: Administrative Vorgabe
- Status des Agenten wird berücksichtigt (Offline/DND/InCall)
- Kontinuierliche Weiterentwicklung
- z.B. bei CCE, Hybrid

SAVE CANCEL

Edit call queue

Name *

CallQueue1

Call agents

Search for an O365 group, distribution list or security group

Type at least 3 characters to start searching

Maximum 50 agents

Maximum calls in the queue *

50 calls

Maximum 200 calls

When the maximum number of calls is reached *

Disconnect with busy signal

How long a call can wait in the queue *

20 minutes 0 seconds

Maximum 45 minutes

When a call times out *

Disconnect

Teams



Microsoft Teams

Skype for Business oder Teams ?

- 2000-2010 Mobilfunktelefone
 - Ersetzen teilweise Festnetzanschlüsse
 - Zielgruppe Consumer
 - Kleiner, leichter, länger
 - Nokia 6110, 6210, 6310 u.a.
 - Telefonie und (teure) SMS, WAP
- 2007 Anfang der Smartphones
 - iPhone 1, MDA3, Blackberry
 - Zielgruppe: „Business“
- 2018
 - Smartphones sind „angekommen“
 - Smartphone und Tablet ersetzen schon PCs



- Wenn Skype ein Mobiltelefon ist..
- Was ist dann Teams ?
- Und seit wann haben Sie ein Smartphone?
- Und wie wichtig ist „Telefonieren“ ?

Microsoft Teams ?



Prä



Plattform

- Neuer Windows Client
- Neuer Mobile Client
- Neues Backend: Cloud Only



Ko



Diskussionsbereiche

- Chat-Rooms
- Persistent
- Connectoren (Twitter/Feeds etc-)
- Wiki



Te



Zusätzliche Karteikaten

- In SharePoint und OneDrive
- OneNote, Planner
- Apps

Teams Roadmap

Meetings roadmap

This document reflects Microsoft's current expectations; however, dates and individual features may change and should not be relied upon in making purchasing decisions.

* Capability has third party dependencies

Available today

Coming in 4Q 2017 (end of qtr)

Coming in 2Q CY2018 (end of qtr)

Calling roadmap

This document reflects Microsoft's current expectations; however, dates and individual features may change and should not be relied upon in making purchasing decisions.

* Capability has third party dependencies

	Coming in 4Q CY2017 (end of qtr)	Coming in 2Q CY2018 (end of qtr)	Coming in 4Q CY2018 (end of qtr)
 Enterprise grade	<ul style="list-style-type: none"> Blind Transfer Call Blocking Call Forwarding Caller ID Masking e911 Support Extension Dialing Translate user input to standard format phone # 	<ul style="list-style-type: none"> Hold Multi-call Handling Simultaneous Ringing Speed Dial Suggested Contacts Voicemail Enable 12c Existing Calling Plan Support 	<ul style="list-style-type: none"> Call Park Group Call Pickup Location-Based Routing Shared Line Appearance
 Skype for Business interop & fed	<ul style="list-style-type: none"> SfB-Teams Calling 	<ul style="list-style-type: none"> Call Support between Teams & Skype Consumer 	

Teams Voicemail

The screenshot shows the Microsoft Teams Voicemail interface. On the left is a navigation pane with options: Aktivität, Chat, Teams, Besprechun..., Anrufe, Dateien, Shop, and Feedback. Below this is a numeric keypad and an 'Ausblenden' button. The main area is titled 'Voicemail' and contains a search bar 'Suchen oder Befehl eingeben'. Below the search bar is a table of voicemail messages:

Name	Dauer	Datum	Uhrzeit	
+49 5257 938802	13 Sek.	14.08.17	02:38	...
+49 5257 938802	6 Sek.	10.08.17	08:58	...
+49 160 900000	5 Sek.	28.07.17	19:18	...
thomas.*****@*****.de	11 Sek.	19.01.17	13:32	...

The second message in the list is highlighted with an orange box. Below the table, there is a section for the selected message. It shows a play button, a progress bar at 00:00, and a '1 x' dropdown menu. To the right of the play button, there is a text box with the following message: 'You received a voice mail from +4952579388082 Voice Mail Preview isn't available for this message. This voice message can't be transcribed. Either the audio quality is poor or the caller left the message in a language that couldn't be recognized.'

Teams Einstellungen

Einstellungen

Allgemein
Benachrichtigungen
Anrufe

Anrufbeantwortungsregeln
Wählen Sie, wie mit eingehenden Anrufen umgegangen werden soll.

Anrufe bei mir klingeln lassen Kein Rufzeichen bei mir

Auch anrufen: Kein anderer

Wenn unbeantwortet: Nichts tun

Voicemail
Voicemails werden in der A
Transkription angezeigt.

Voicemail
Neue Nummer oder neuer Kontakt
Nichts tun

Voicemail-Begrüßung ändern

Barrierefreiheit
Aktivieren Sie TTY, um telefonisch mit Text zu kommunizieren. Damit dies funktioniert, müssen Sie ein TTY-Gerät anschließen.

TTY-Modus aktivieren

Anrufe blockieren

Anrufe ohne Anrufer-ID blockieren

Bevorzugte Anruferanwendung
Wählen Sie eine Standard-App für eingehende Anrufe.

Skype for Business / Lync
Microsoft Teams
Skype for Business / Lync

Teams ersetzt Skype Business ?



red by Rachfahl IT-Solutions

Danke an unsere Partner!

Platinum Sponsor



Gold Sponsoren



Danke an unsere Partner!

Gold Sponsoren

